

## INDEX OF MAIN PRODUCTS

CATEGORY	PRODUCT	Page
WINCHES , CAPSTANS, CHAIN STOPPERS	<a href="#">Manual coupling winch</a>	<a href="#">2</a>
	<a href="#">Hydraulic coupling winch</a>	<a href="#">3</a>
	<a href="#">Anchor &amp; Mooring winch-AMW</a> - Electric or hydraulic drive	<a href="#">4</a>
	<a href="#">Anchor &amp; Mooring winch-AMW</a> - with STAFFA hydraulic motor	<a href="#">5</a>
	<a href="#">Anchor &amp; Mooring winch-AMW</a> - Electro-hydraulic drive	<a href="#">6</a>
	<a href="#">Anchor &amp; Mooring winch-AMW</a> - DIESEL drive	<a href="#">7</a>
	<a href="#">Mooring winch with spooling device</a>	<a href="#">8</a>
	<a href="#">Tugger winch</a>	<a href="#">9</a>
	<a href="#">Reel winch</a>	<a href="#">10</a>
	<a href="#">Manual driven winch</a>	<a href="#">11</a>
	<a href="#">Mooring capstans</a>	<a href="#">12</a>
	<a href="#">Anchor &amp; Mooring capstans</a>	<a href="#">13</a>
	<a href="#">Knife chain stopper</a>	<a href="#">14</a>
	<a href="#">Friction chain stopper</a>	<a href="#">15</a>
<a href="#">Roller chain stopper</a>	<a href="#">16</a>	
SINGLE FAIRLEADS, DOUBLE FAIRLEADS	<a href="#">Simple fairleads</a>	<a href="#">17</a>
	<a href="#">Double fairleads</a>	<a href="#">18</a>
	<a href="#">Warping roller - DIN 81906</a>	<a href="#">19</a>
WARPING ROLLERS	<a href="#">Warping roller - EU</a>	<a href="#">20</a>
	<a href="#">Warping roller - DIN G</a>	<a href="#">21</a>
	<a href="#">Warping roller with cylindrical socket</a>	<a href="#">22</a>
	<a href="#">Warping roller with conical socket</a>	<a href="#">23</a>
CHOCKS	<a href="#">Chocks - type A - DIN 81915</a>	<a href="#">24</a>
	<a href="#">Chocks - type C - DIN 81915</a>	<a href="#">25</a>
SMIT BRACKET	<a href="#">Smit bracket</a>	<a href="#">26</a>
END FASTENING	<a href="#">End fastening</a>	<a href="#">27</a>

## MANUAL COUPLING WINCH

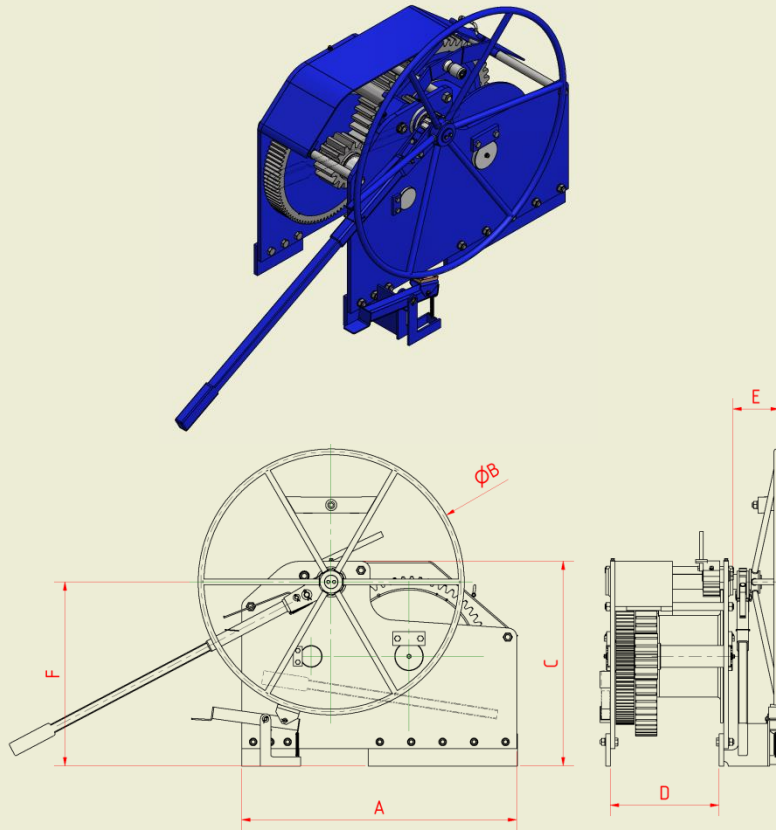

Winch type	MCW -25	MCW-40	MCW-60
Cable diameter (mm)	20	26	34
Storage capacity (m/3 layers)	34	40	34
Max. static force (kN)	250	400	600
Traction force by hand wheel (kN)	25	40	75
Traction force by ratchet lever (kN)	55	95	170

MAIN DIMENSION (mm)	A	B	C	D	E	F
MCW-25	900	824	654	470	205	585
MCW-40	880	1020	725	520	204	660
MCW-60	1200	1160	875	514	204	785

CODIFICATION: MCW - 40 - R - A

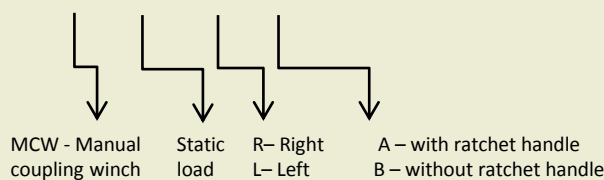

## HYDRAULIC COUPLING WINCH

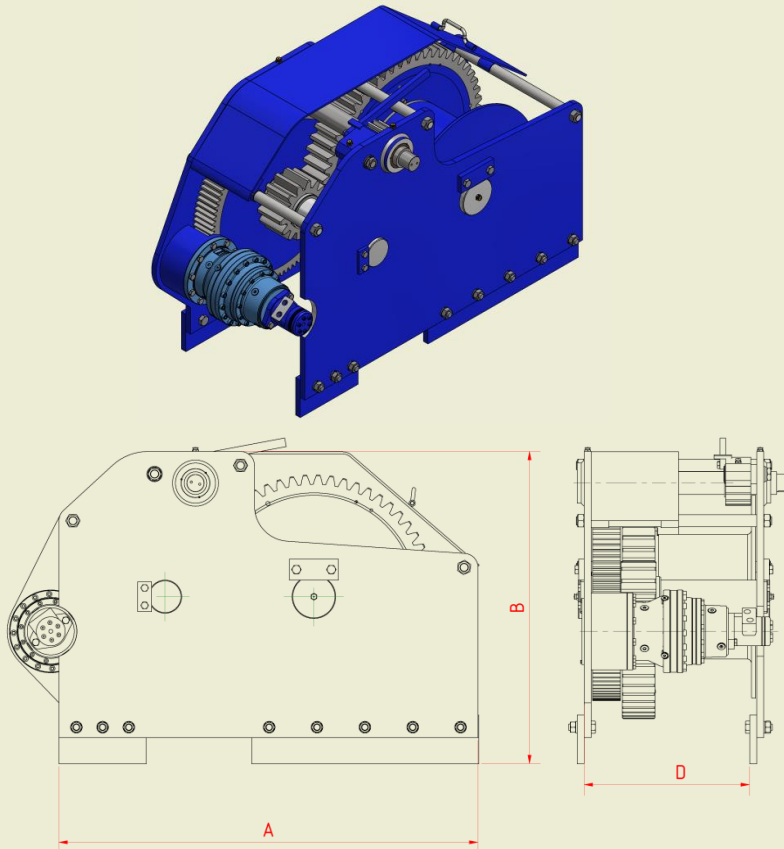

Winch type	HCW -25	HCW-40	HCW-60
Cable diameter (mm)	20	26	34
Storage capacity (m/3 layers)	34	40	34
Max. static force (kN)	250	400	600
Traction force by hydraulic motor (kN)	45	60	60
Working pressure (bar)	55	104	50

MAIN DIMENSION (mm)	A	B	D
HCW-25	900	654	470
HCW-40	880	725	520
HCW-60	1200	875	514

CODIFICATION: HCW - 40 - R

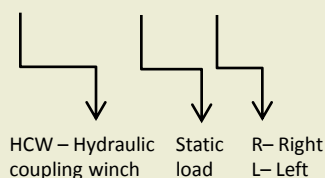

## ANCHOR & MOORING WINCH - Electric or hydraulic drive

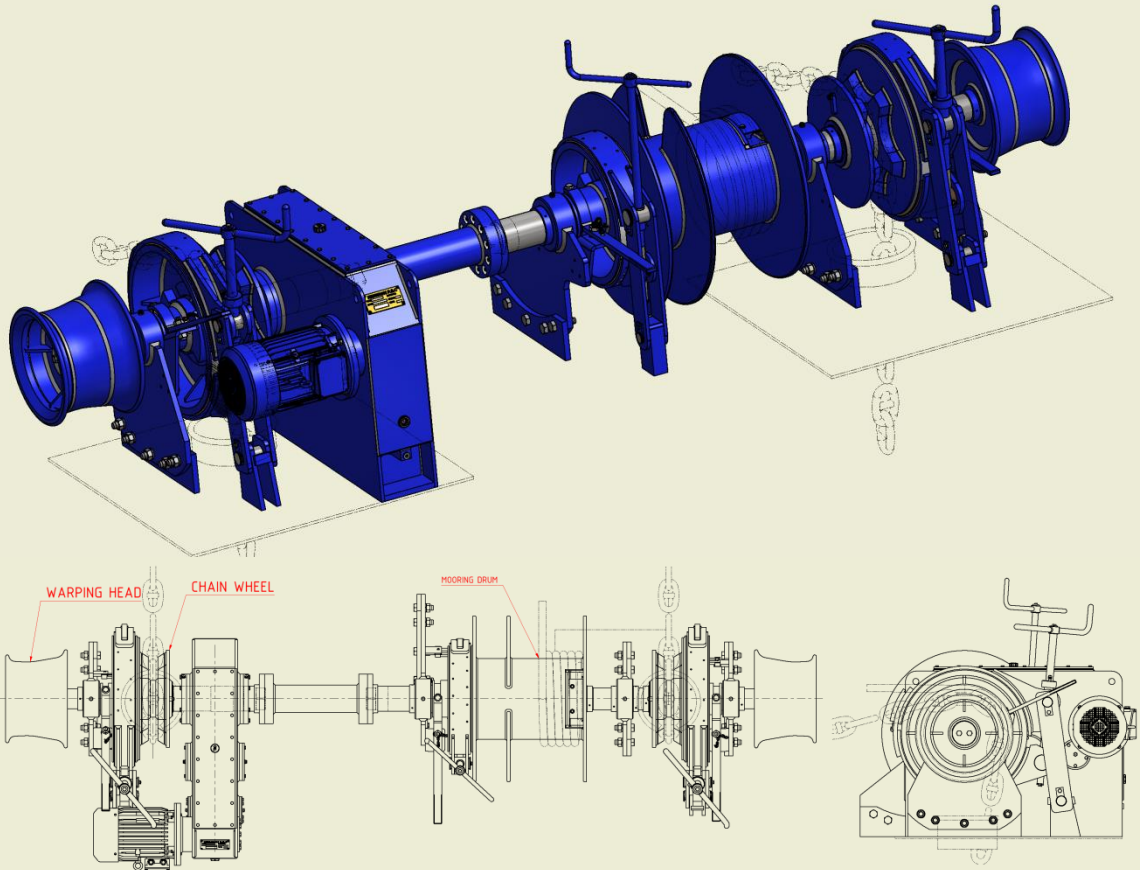

Drive type	Electric, Hydraulic
Stud-link chain size (mm)	12– 48
Brake type	Band brake – manual operated
Clutch type	Dog clutch - Manual operated
Static force	80 % x MBL of chain
Power supply	380 V / 50Hz ( or 60 Hz)
Hauling speed steps	One / Two / Three

- SPECIAL OPTIONS:**
- Remote control for brake releasing from the wheel house;
  - ATEX construction;
  - Foundation ;
  - Chain wheel for DIN 766 chain type;
  - Counter for speed and chain length;
  - Grooved mooring drum;
  - Clutch and brake with hydraulic operation;
  - Manual operation;

**CODIFICATION: AMW - WCRDCW - E 36 / 2**

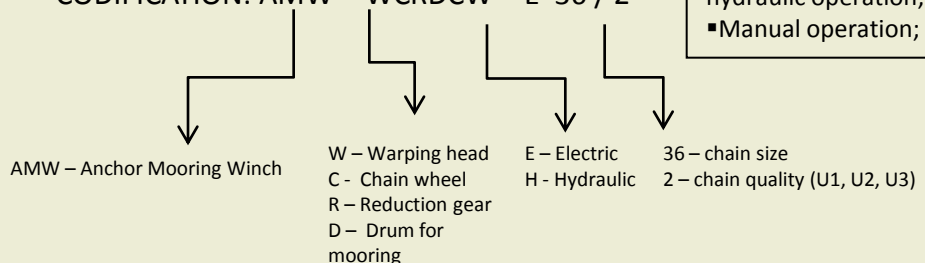

## ANCHOR & MOORING WINCH - with STAFFA hydraulic motor

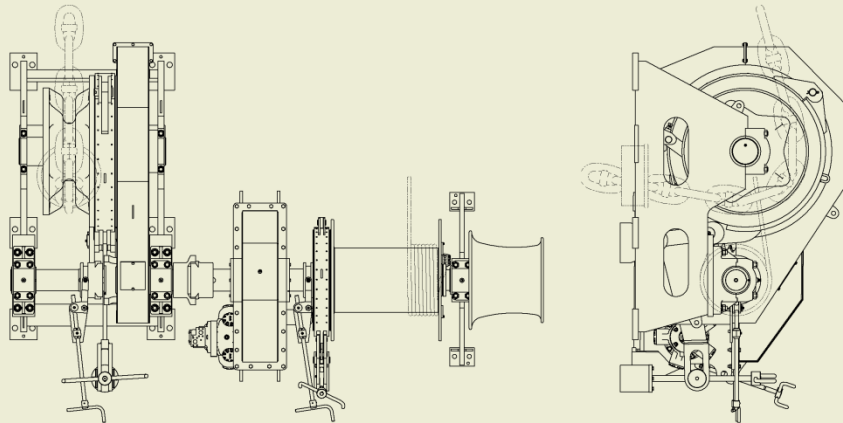
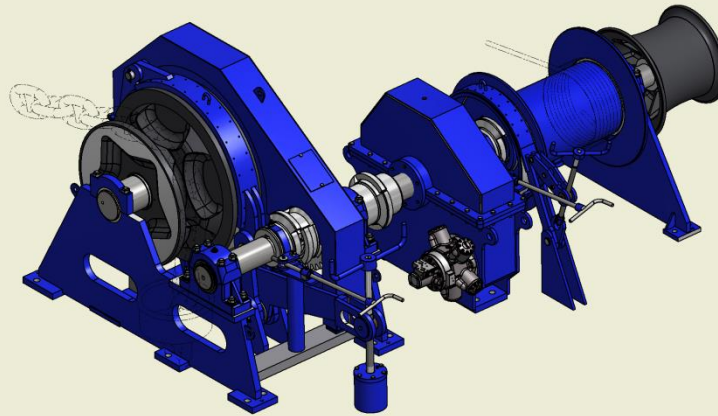

Drive type	STAFFA motor HMC type
Stud-link chain size (mm)	54k2 – 100 k2
Brake type	Band brake – manual operated
Clutch type	Dog clutch - Manual operated
Static force	80 % x MBL of chain
HPU supply parameters.	Max. 250 bar / 200 liters
Hauling speed steps	One / Two

### SPECIAL OPTIONS:

- Remote control for brake releasing from the wheel house;
- ATEX construction;
- Foundation ;
- Grooved mooring drum;
- Clutch and brake with hydraulic operation;

CODIFICATION: AMW - CRDW - H 54 / 2

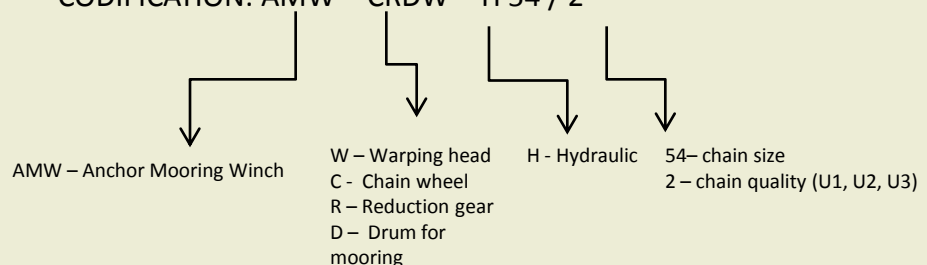

## ANCHOR & MOORING WINCH - Electro-hydraulic drive

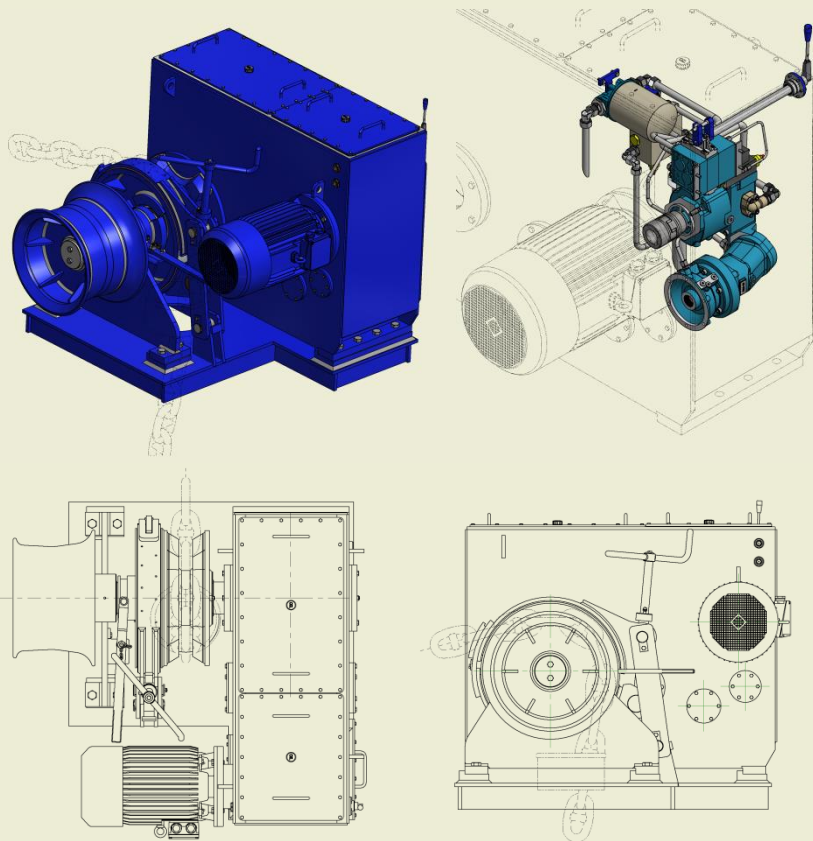

Drive type	Electro-Hydraulic
Stud-link chain size (mm)	19– 54
Brake type	Band brake – manual operated
Clutch type	Dog clutch - Manual operated
Static force	80 % x MBL of chain
Power supply	380 V / 50Hz ( or 60 Hz)
Electric motor type	IP 56 – T.E.N.V.
Note: All hydraulic part are mounted in the gear box.	

### SPECIAL OPTIONS:

- Remote control for brake releasing from the wheel house;
- ATEX construction;
- Foundation ;
- Chain wheel for DIN 766 chain type;
- Counter for speed and chain length;
- Grooved mooring drum;
- Clutch and brake with hydraulic operation;

CODIFICATION: AMW - WCRDCW - EH 36 / 2

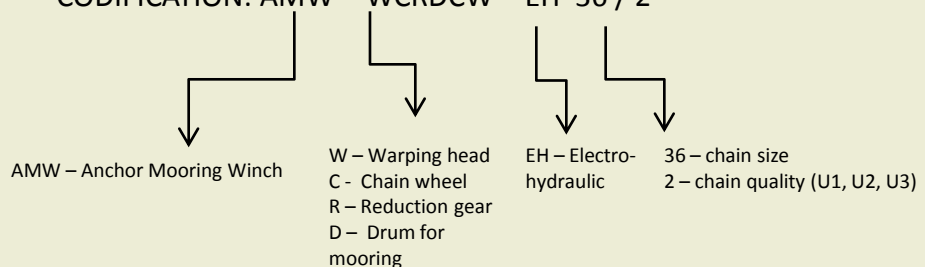

## ANCHOR & MOORING WINCH - DIESEL drive

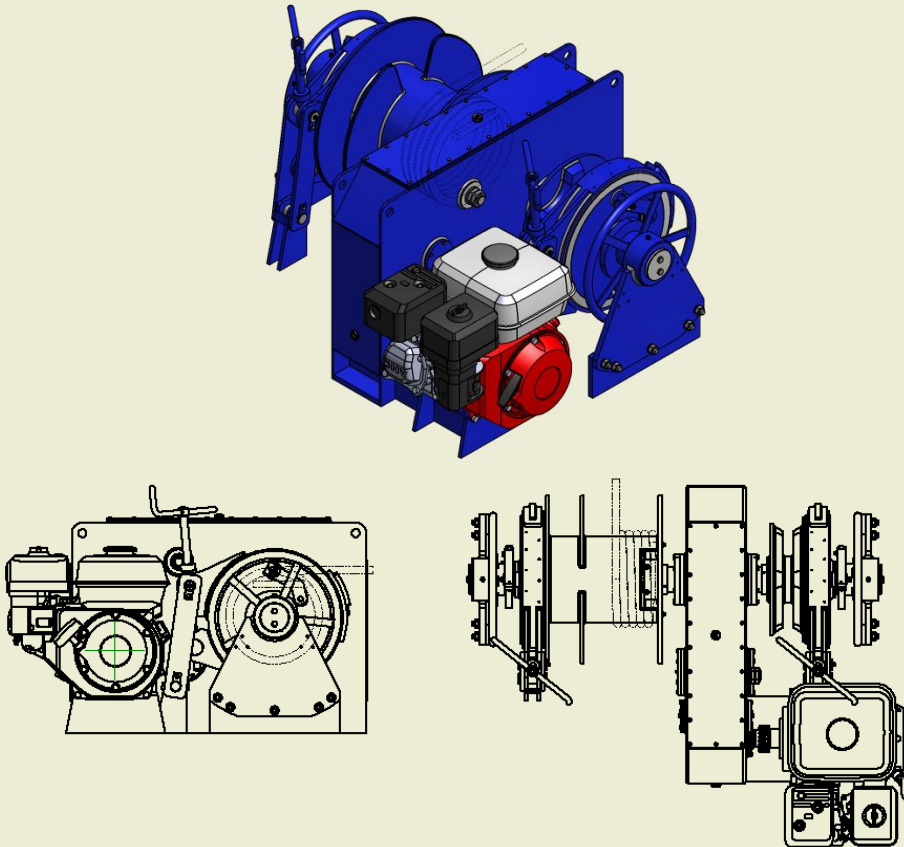

Drive type	DIESEL engine
Stud-link chain size (mm)	28 – 36
Brake type	Band brake – manual operated
Clutch type	Friction type
Static force	80 % x MBL of chain
Fuel type	Diesel fuel
DIESEL motor type	HATZ

### SPECIAL OPTIONS:

- Remote control for brake releasing from the wheel house;
- Foundation ;
- Chain wheel for DIN 766 chain type;
- Counter for speed and chain length;
- Grooved mooring drum;

CODIFICATION: AMW - WCRDCW - D 36 / 2

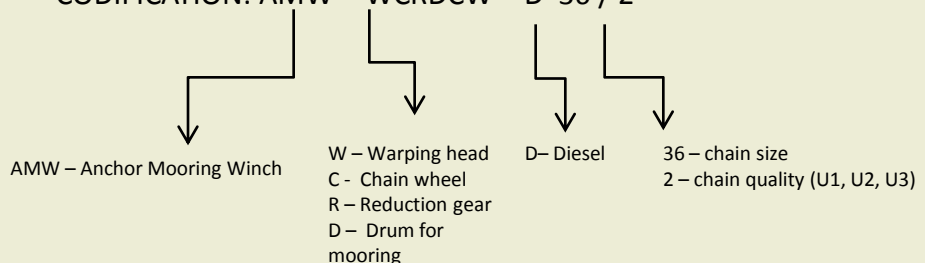

## MOORING WINCH - with spooling device

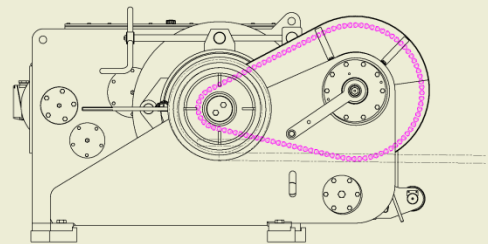
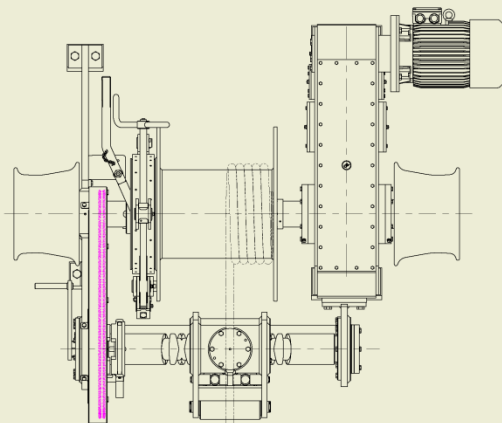
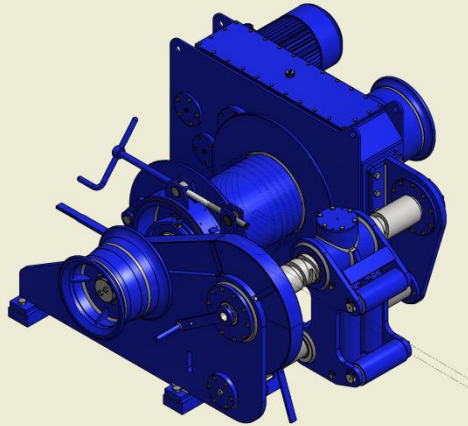

Drive type	Electric or hydraulic
Traction force range (kN)	60 – 250
Brake type	Band brake – manual operated
Clutch type	Dog clutch – manual operated
Rope type	Steel cable I or nylon rope
Power supply	380 V / 50 Hz ( or 60 hz)
Mooring speed steps	One / two

### SPECIAL OPTIONS:

- Remote control for brake releasing from the wheel house;
- Foundation ;
- Counter for speed and chain length;
- Grooved mooring drum;
- Automatic friction clutch.

CODIFICATION: MW - WRDW - E 150 kN

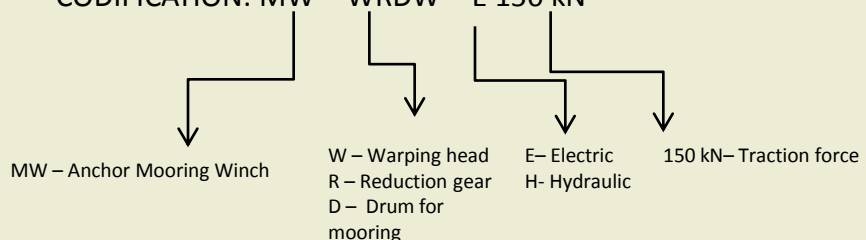



## TUGGER WINCH

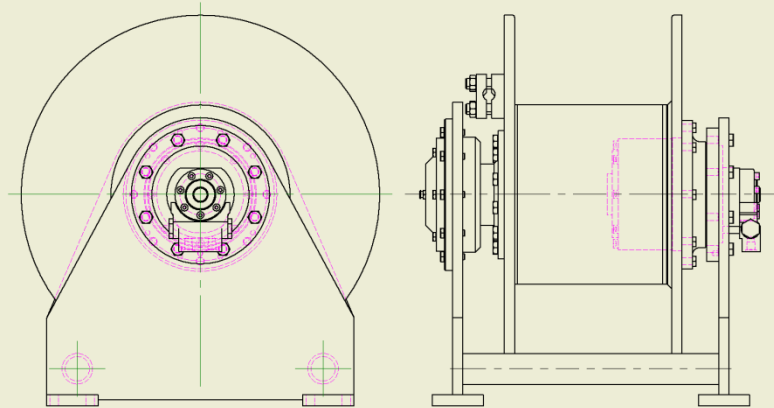
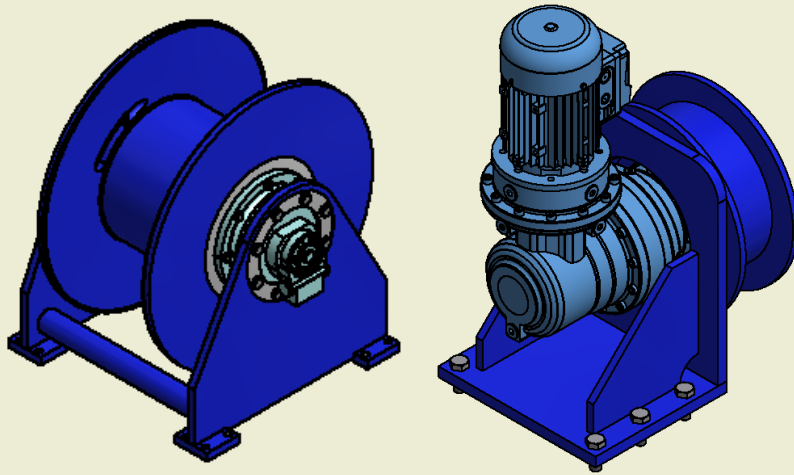

Drive type	Electric or hydraulic
Traction force range (kN)	10 – 100
Brake type	Multidisc hyd. Brake (or EM brake)
Standard drum type	Non-grooved
Rope type	Steel cable
Power supply	380 V / 50 Hz ( or 60 Hz)
Mooring speed steps	One / two

### SPECIAL OPTIONS:

- Grooved drum;
- Drum guards;
- Encoder for spindle limiter;
- Explosion proof motor;
- Load limiter;
- Frequency inverter for variable speed control;
- Motor in vertical position;

CODIFICATION: TW - E 75 kN

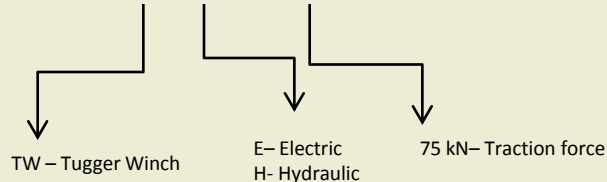

## REEL WINCH

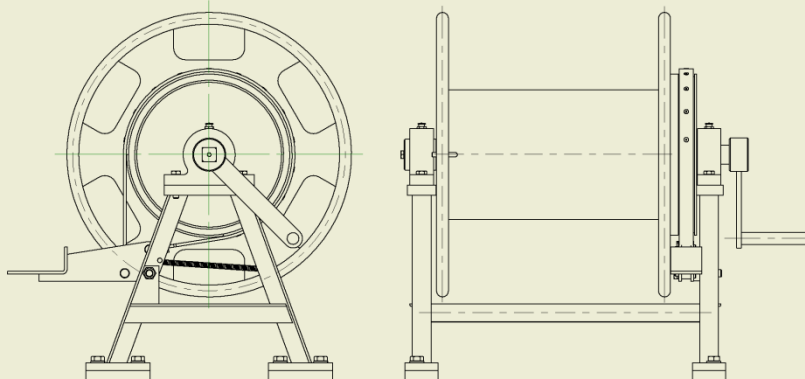
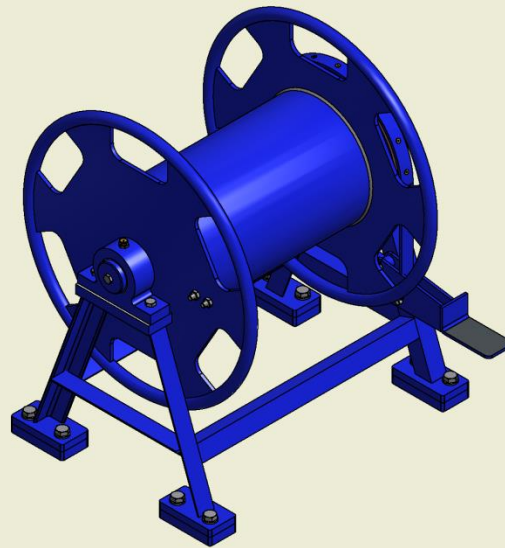

Drive type	Manually
Steel cable diameter (mm)	10 – 24
Brake type	Foot Band brake
Standard drum type	Non-grooved
Storage capacity	~400 m

**SPECIAL OPTIONS:**

- Electric driven

CODIFICATION: RW - M 16©

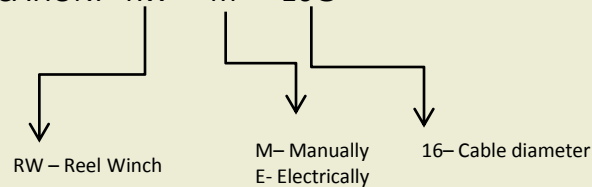

## MANUAL DRIVEN WINCH

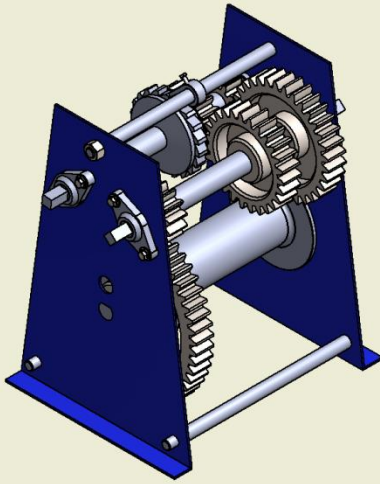

1. Traction manual winch

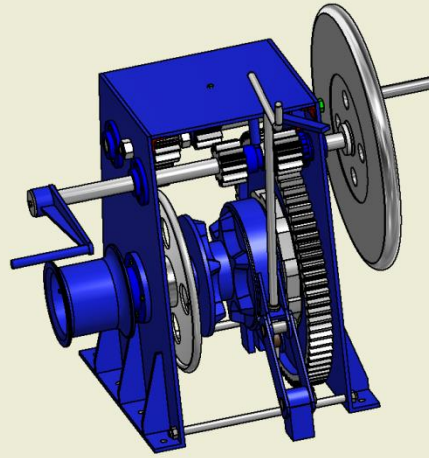

2. Anchor manual winch

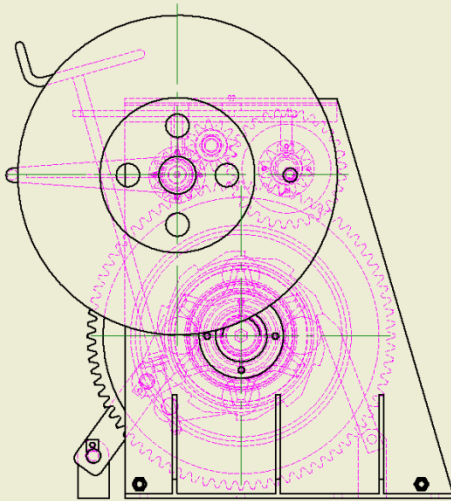

Anchor winch

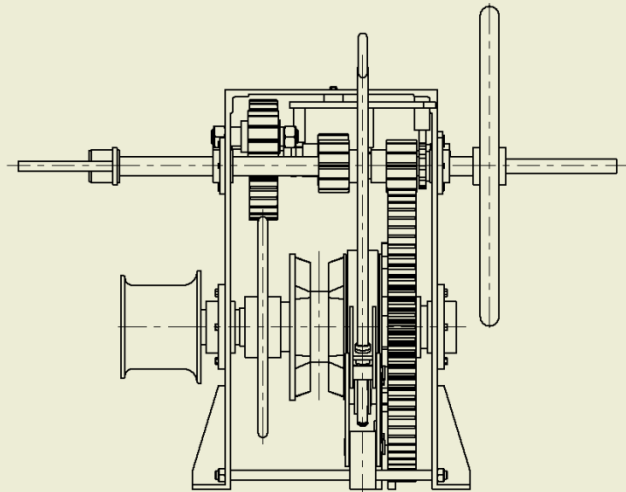

Drive type	Manually
Chain size (DIN 766)	10 – 23 k2
Brake type	Band brake
Pull force range (Traction winch)	1000 – 10.000 kg
Storage capacity	~70m

SPECIAL OPTIONS:  
 ■With anchor drum;

CODIFICATION: AW - M16©

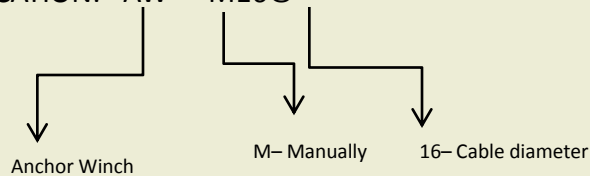

## MOORING CAPSTANS

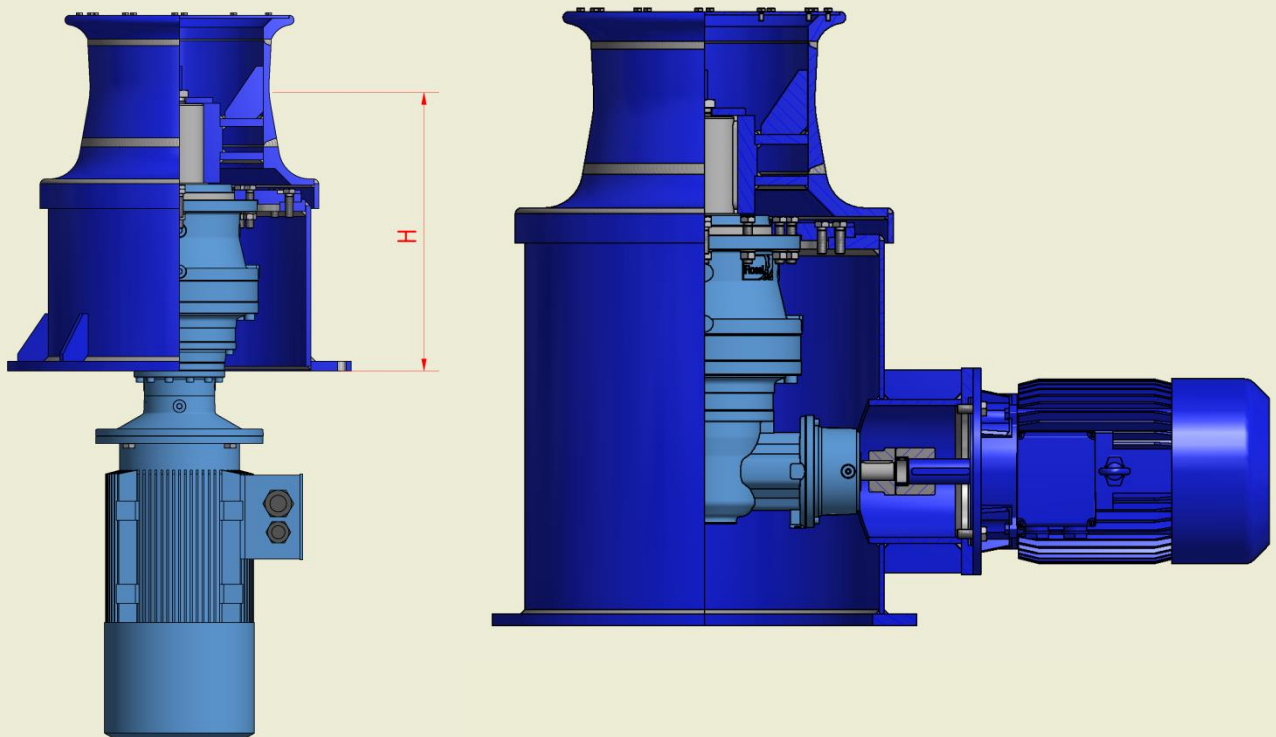

Drive type	Electric or hydraulic
Traction force range (kN)	15 – 100
Brake type	EM brake
Rope type	Synthetics rope
Power supply	380 V / 50 Hz
Mooring speed steps	One / two

- SPECIAL OPTIONS:**
- Explosion proof motor;
  - Load limiter;
  - Frequency inverter for variable speed control;
  - Motor in horizontal position;
  - Horizontal warping head;
  - 440 V / 60 Hz supply

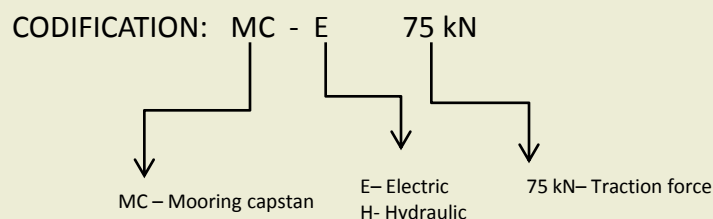

## ANCHOR & MOORING CAPSTANS

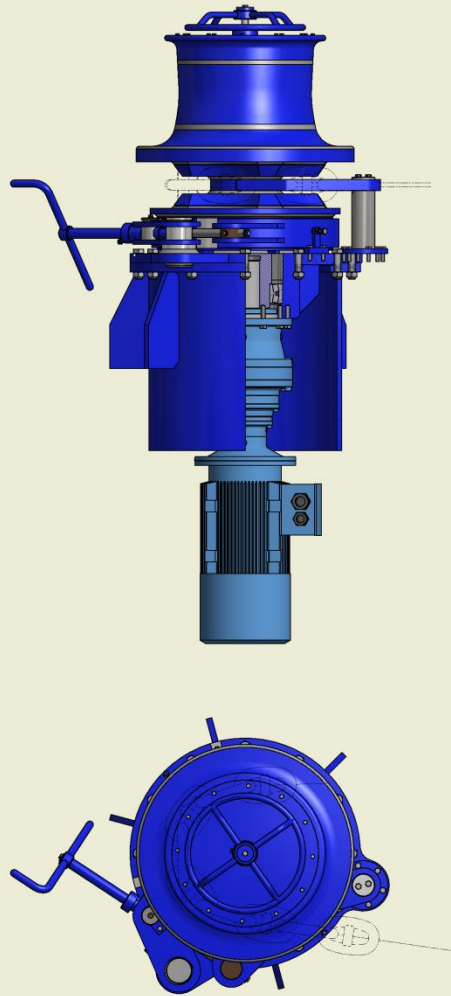

Drive type	Electric or hydraulic
Stud-link chain diameter	12– 36
Brake type	EM brake
Rope type	Synthetics rope
Power supply	380 V / 50 Hz
Mooring speed steps	One / two

### SPECIAL OPTIONS:

- Explosion proof motor;
- Frequency inverter for variable speed control;
- Motor in horizontal position;
- Horizontal warping head;
- 440 V / 60 Hz supply

CODIFICATION: AMC - E 36 / 2

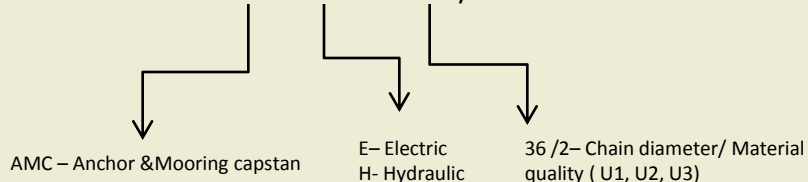

## KNIFE CHAIN STOPPER

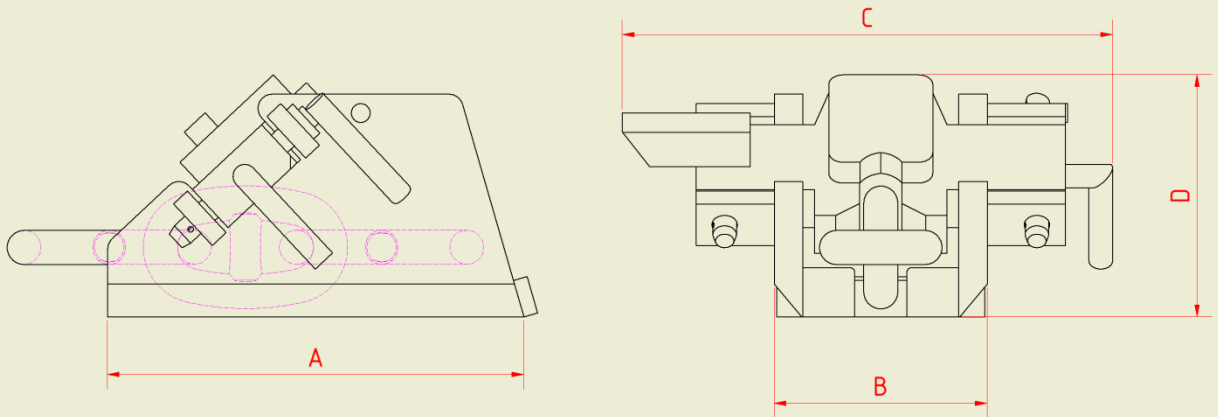
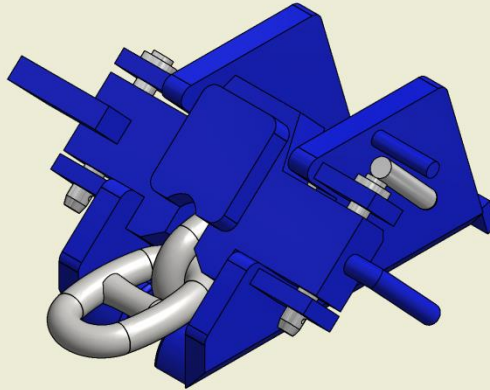

Stopper size	Chain diameter / Chain size	A	B	C	D
1	12,5 – 17,5 / K2	200	114	262	115
2	19 -22 / K2	300	160	348	150
3	24-26 / K2	300	166	400	196
4	28 – 32 / K2	400	225	497	226
5	34 – 36 / K2	440	225	518	248
6	38 -40 / K2	476	276	592	268

CODIFICATION: KCS - 12k2

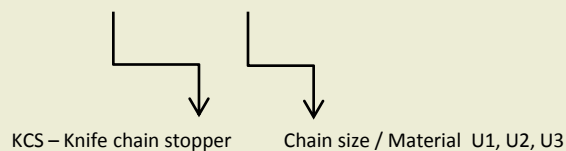

## FRICION CHAIN STOPPER

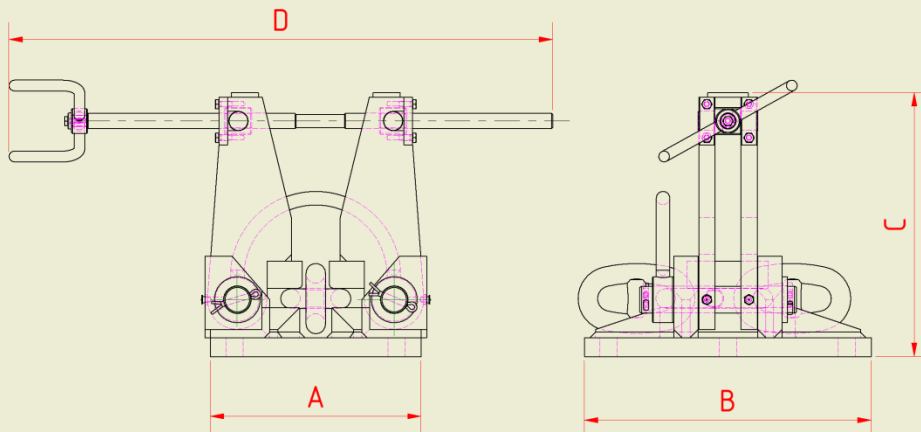
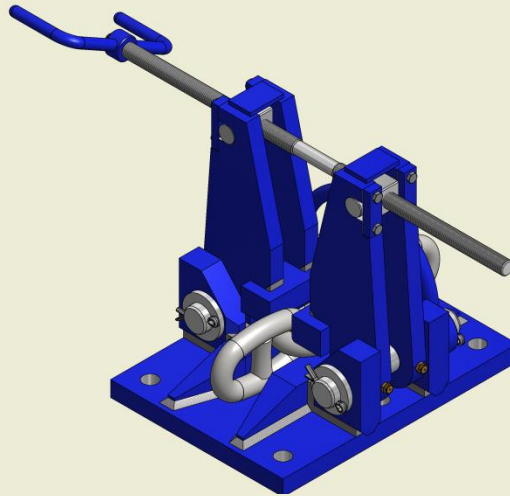

Stopper size	Chain diameter / Chain size	A	B	C	D
1	12,5 – 17,5 / K2	190	280	260	550
2	19 -22 / K2	250	330	280	600
3	24 / K2	270	380	350	650
4	26 – 28 / K2	280	420	435	795
5	34 – 36 / K2	390	530	490	935
6	40 -44 / K2	410	625	525	975
7	46 – 50 / k2	420	750	620	1150

CODIFICATION: FCS - 12k2

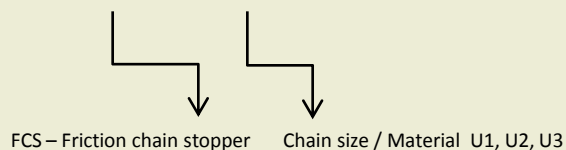

## ROLLER CHAIN STOPPER

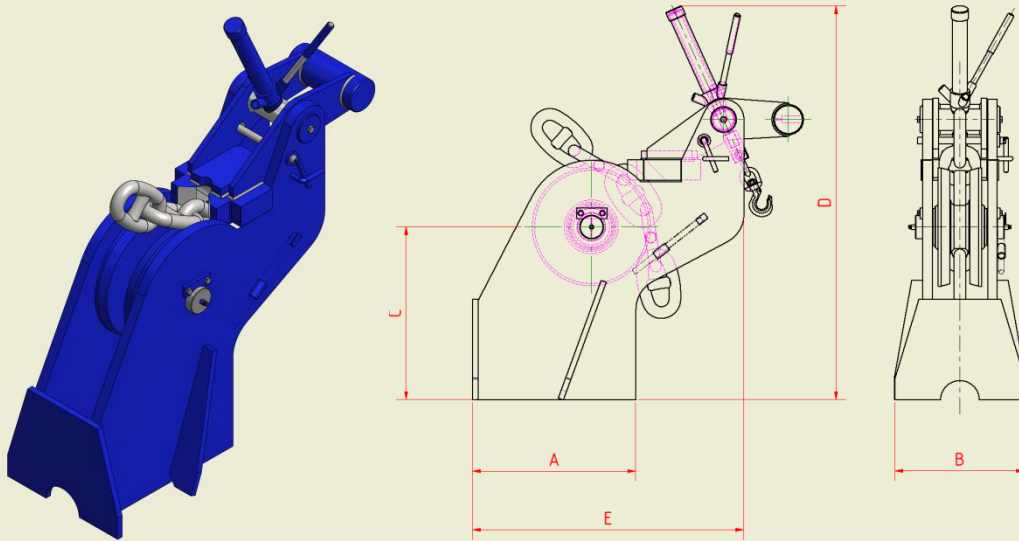

Stopper size	Chain diameter / Chain size	A	B	C	D	E
1	12,5 – 14 / K3	200	110	150	400	325
2	16 -17,5 / K3	240	215	170	450	370
3	19 – 20,5 / K3	250	240	210	500	340
4	22 – 24 / K3	350	300	250	650	625
5	26– 28 / K3	400	350	280	960	710
6	30 -32 / K3	490	380	320	970	805
7	34 -36/ k3	540	465	380	940	915
8	38 -40 / K3	610	540	380	1040	920
9	42 – 44/ K3	660	600	460	1018	1100
10	46 – 48 / K3	720	660	480	1135	1215
11	50 – 52 / K3	750	710	520	1225	1374
12	54 – 56 / K3	755	760	560	1370	1380

Note. All dimension from the table are informative

CODIFICATION: RCS - 32k2

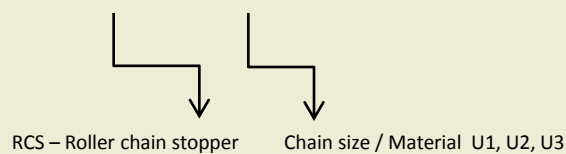





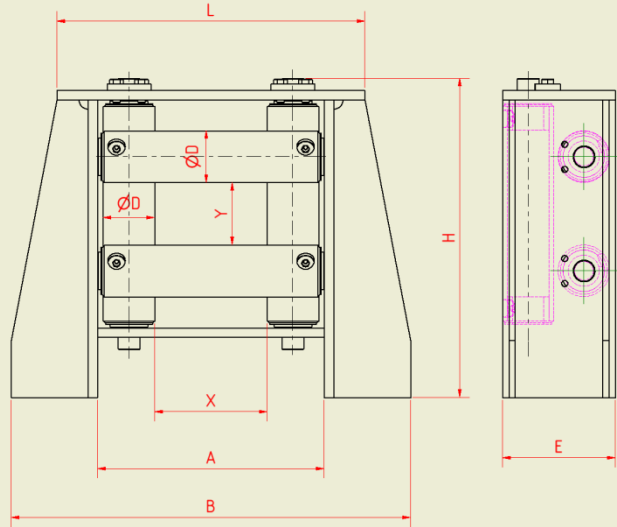
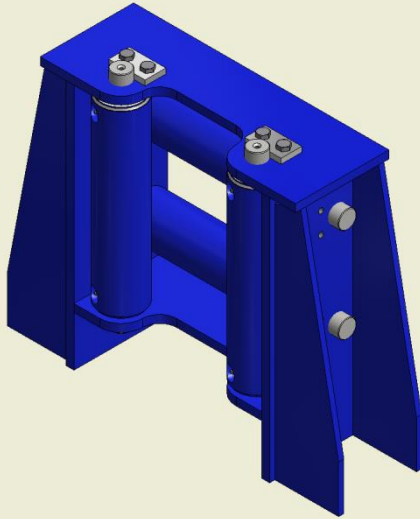













## SIMPLE FAIRLEADS



Note. All dimensions from the table are informative

Type	Nominal pull (kN)	Wire $\phi$	Rope $\phi$	A	B	$\phi D$	E	H	L	X x Y
FA4-12	20	12	22	640	364	82,5	180	490	460	180 x 100
FA4-16	30	16	28	170	450	101,6	220	610	590	230 x 120
FA4-20	50	20	36	210	500	127	270	715	700	250 x 140
FA4-24	80	24	48	250	650	139,7	300	800	800	280 x 150
FA4-32	120	32	60	280	960	177,8	370	915	1000	300 x 160
FA4-36	160	36	72	320	970	194	410	1005	1100	320 x 170
FA4-40	200	40	78	380	940	244,5	500	1145	1150	340 x 180
FA4-48	320	48	96	380	1040	299	610	1355	1500	400 x 250

Simple fairleads- Construction type

	FA 4	FB 5-G	FA5-R	FA5-L	FA6 - A	FB6 - GR	FB6 - GL	FB7 - GA
Side view								
Top view								

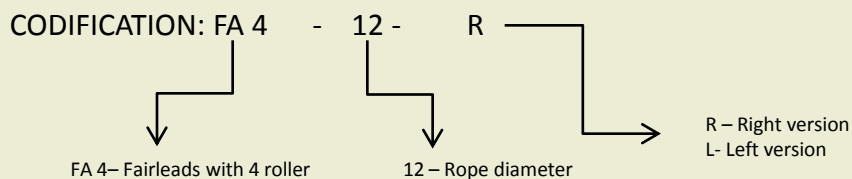



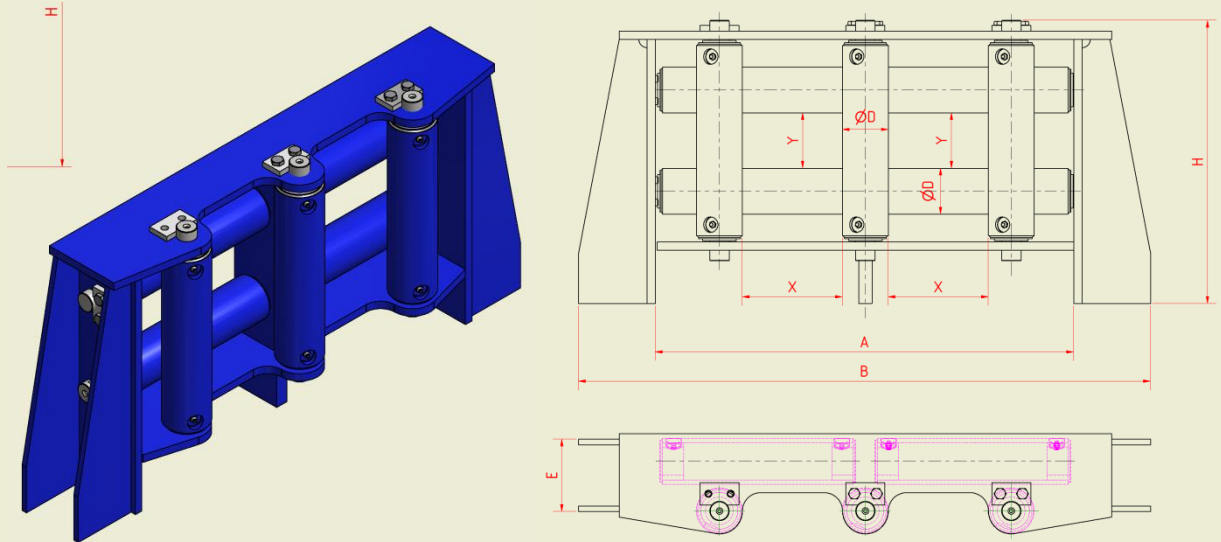













## DOUBLE FAIRLEADS



Note. All dimensions from the table are informative

Type	Load (kN)	Wire $\phi$	Rope $\phi$	A	B	$\phi D$	E	H	X x Y
FA7-D12	20	12	22	626	914	82,5	180	490	180 x 100
FA7-D16	30	16	28	786	1130	101,6	220	610	230 x 120
FA7-D20	50	20	36	900	1270	127	270	715	250 x 140
FA7-D24	80	24	48	1000	1420	139,7	300	800	280 x 150
FA7-D32	120	32	60	1150	1680	177,8	370	915	300 x 160
FA7-D36	160	36	72	1250	1820	194	410	1005	320 x 170
FA7-D40	200	40	78	1440	1940	244,5	500	1145	340 x 180
FA7-D48	320	48	96	1720	2400	299	610	1355	400 x 250

Double fairleads- Construction type

	FA7-D	FA8-DM	FA8-DL	FA8-DR	FA9-DLRM	FA9-DRM	FA9-DLM	FA10-DA
Side view								
Top view								

CODIFICATION: FA 7 - DR12

FA 7- Fairleads with 7 roller

Double - Right- 12 kN

## WARPING ROLLER - DIN 81906

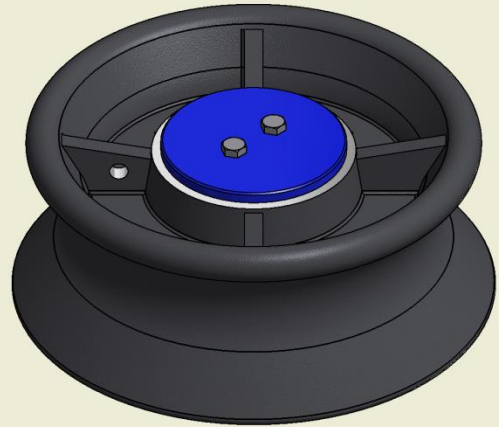
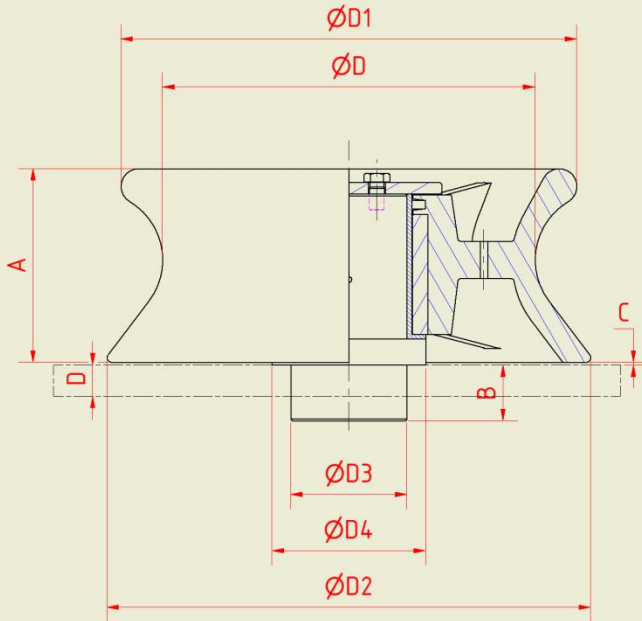

Type	Nominal pull (kN)	$\varnothing D$	$\varnothing D1$	$\varnothing D2$	$\varnothing D3$	$\varnothing D3$	A	B	C	D
DIN-1	10	160	195	210	60	85	80	50	2	12
DIN-2	20	200	245	265	70	95	102	50	3	12
DIN-3	32	250	300	330	85	110	126	50	3	15
DIN-5	50	320	390	420	106	140	160	50	3	15
DIN-8	80	400	490	530	125	165	208	60	3	18
DIN-12	120	450	560	610	160	200	256	85	3	18
DIN-20	200	500	620	640	190	245	278	100	5	20
DIN-32	320	560	740	780	230	290	348	150	5	20

CODIFICATION: DIN - 1

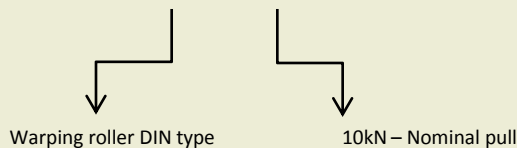

## WARPING ROLLER - EU

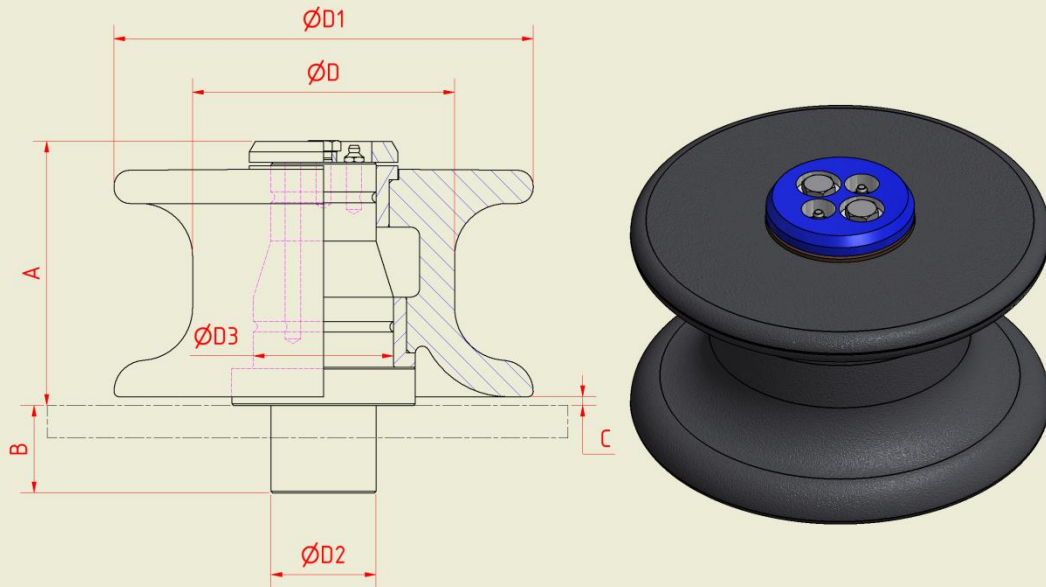

Type	Braking load (To)	ØD	ØD1	ØD2	ØD3	A	B	C
EU-150	13	150	240	90	79	154	50	5
EU-200	21	200	310	115	99	186	50	5
EU-250	28	250	380	135	119	230	50	6
EU-300	42	300	440	155	129	255	50	7
EU-350	61	350	500	175	149	271	50	7
EU-400	74	400	560	195	159	307	60	7
EU-450	90	450	630	210	179	316	84	7

CODIFICATION: EU - 1

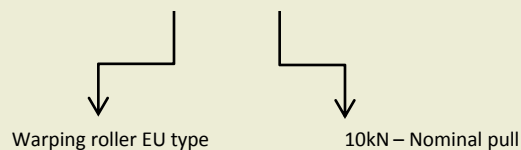

## WARPING ROLLER - DIN G

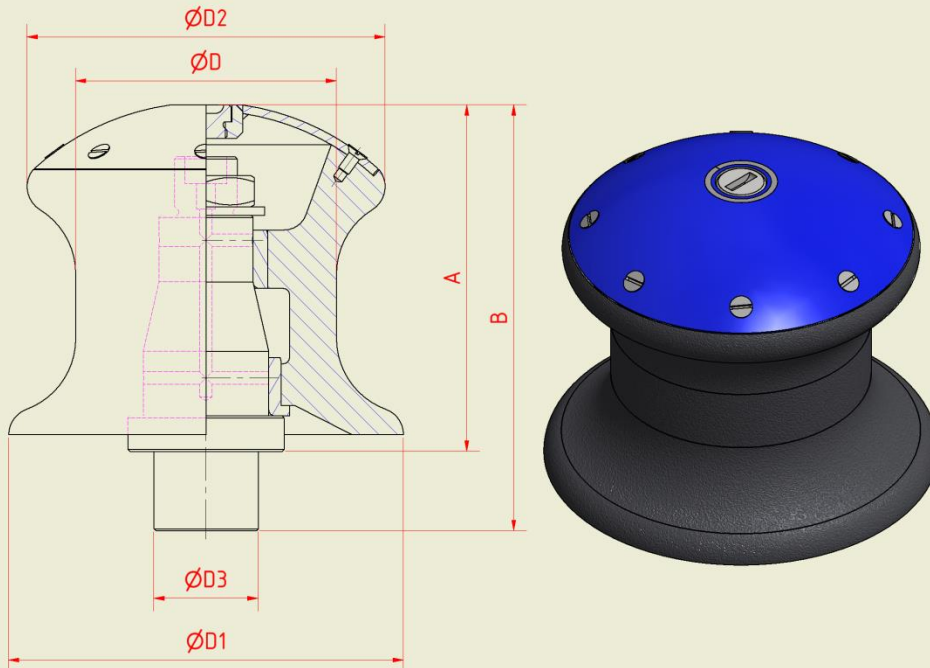

Type	Nominal load (kN)	ØD	ØD1	ØD2	ØD3	B	A
G-1	10	100	160	150	40	170	132
G-2	20	125	180	172	50	200	159
G-3	31,5	160	240	220	60	231	188
G-5	50	200	310	280	80	284	232
G-8	80	250	380	340	90	339	277
G-12	125	320	470	430	110	373	306
G-20	200	400	560	510	140	443	370
G-32	315	500	700	640	180	512	430

CODIFICATION: G - 1

Warping roller G type

10kN – Nominal pull

## WARPING ROLLER WITH CYLINDRICAL SOCKET

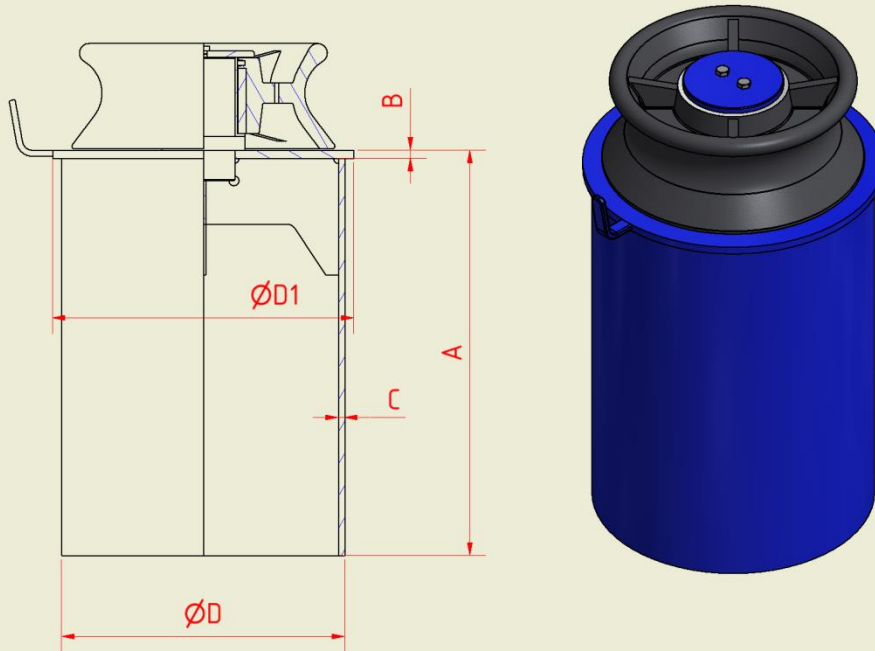

Type	Nominal load (kN)	ØD	ØD1	A	B	C
WRCS-1	10	219,1	245	200-800	15	12,5
WRCS-2	20	273	310	200-800	15	12,5
WRCS-3	30	355,6	385	200-800	15	12,5
WRCS-5	50	457,2	485	200-800	15	12,5
WRCS-8	80	558,8	585	200-800	15	12,5
WRCS-12	120	660,4	620	200-600	18	14,5
WRCS-20	200	660,4	750	200-600	18	17,5
WRCS-32	320	812,8	845	200-600	20	16

CODIFICATION: WRCS - 1

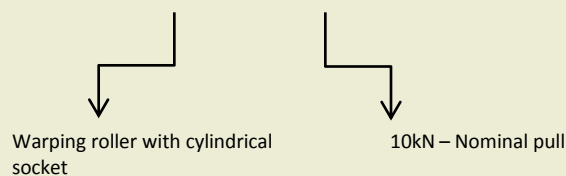

## WARPING ROLLER WITH CONICAL SOCKET

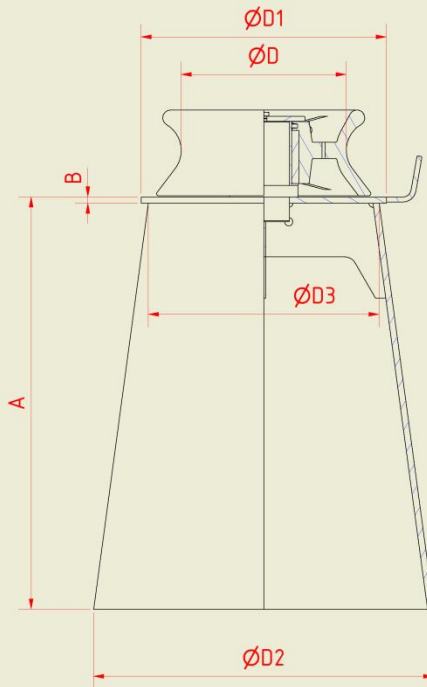

Type	Nominal load (kN)	ØD	ØD1	ØD2	ØD3	A	B	C
WRC-8-1	80	400	595	825	560	1000	15	15
WRC-12-1	125	450	705	925	660	800	15	15
WRC-12-2	125	450	705	975	660	1000	15	15
WRC-20-1	200	500	705	870	660	800	20	15
WRC-20-2	200	500	705	925	660	1000	20	15
WRC-20-3	200	500	705	975	660	1200	20	15
WRC-20-4	200	500	705	1030	660	1400	20	15
WRC-32-1	320	560	865	1020	810	800	20	15
WRC-32-2	320	560	865	1075	810	1000	20	15
WRC-32-3	320	560	865	1125	810	1200	20	15
WRC-32-4	320	560	865	1180	810	1400	20	15

CODIFICATION: WRC - 8 - 1

Warping roller with conical socket

80kN - Nominal pull

Height version - A=1000

## CHOCKS – type A- DIN 81915

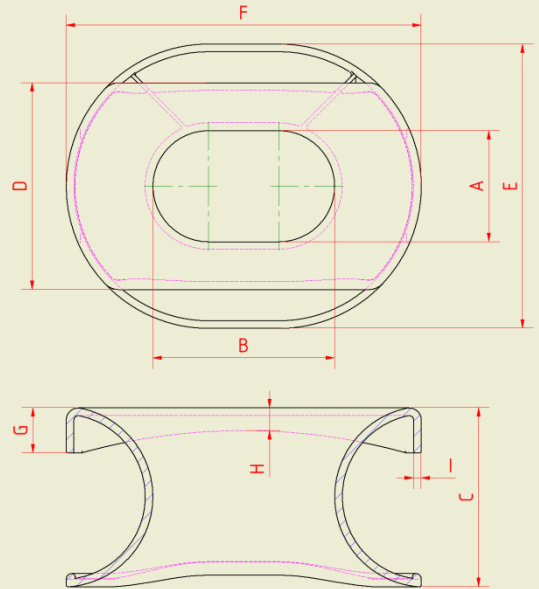
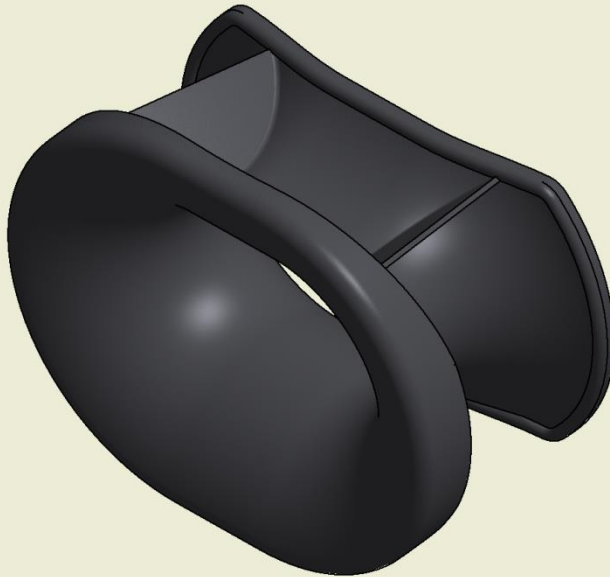

Type	Load (kN)	A	B	C	D	E	F	G	H	I
CA-1	10	90	125	160	175	250	285	65	20	10
CA-2	20	115	160	200	225	315	360	70	25	12
CA-3	30	140	200	250	275	390	450	75	32	14
CA-5	50	180	250	300	340	480	550	80	38	16
CA-8	80	225	320	360	415	585	680	90	45	18
CA-12	120	270	400	440	500	710	840	110	55	20
CA-20	200	320	500	520	595	840	1020	130	65	22
CA-30	320	400	600	700	800	1100	1300	150	80	35

CODIFICATION: CA - 8

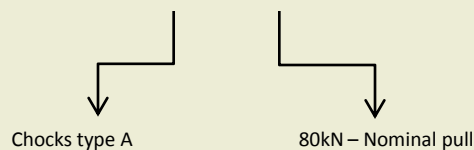



## CHOCKS – type C- DIN 81915

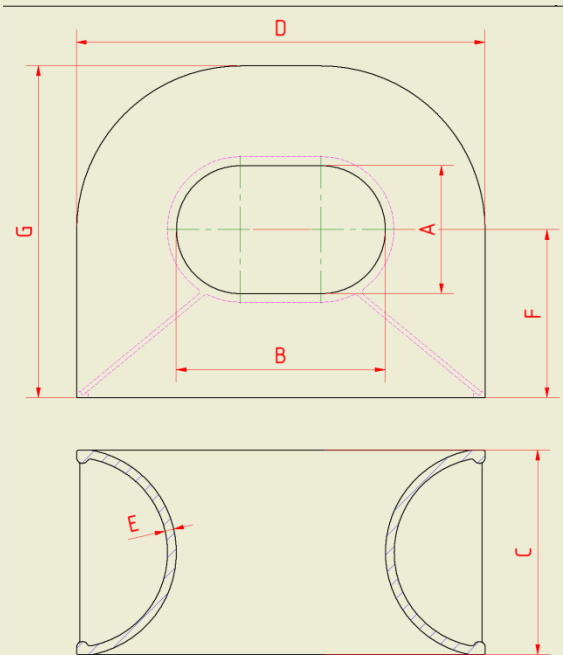
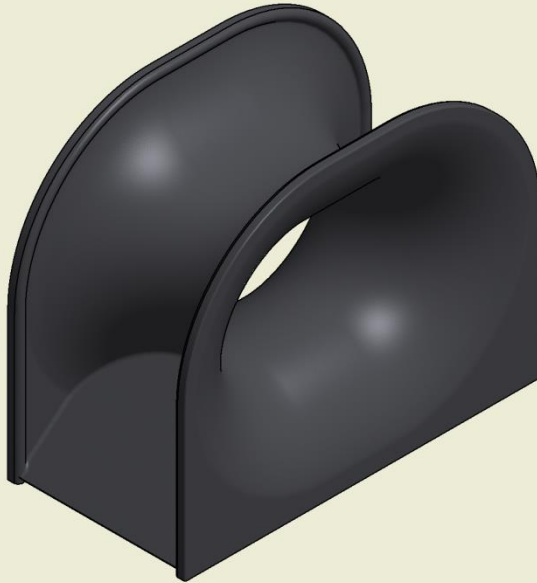

Type	Load (kN)	A	B	C	D	E	F	G
CC-1	10	90	125	160	285	10	125	65
CC-2	20	115	160	200	360	12	157,5	70
CC-3	30	140	200	250	450	14	195	75
CC-5	50	180	250	300	550	16	240	80
CC-8	80	225	320	360	680	18	292,5	90
CC-12	120	270	400	440	840	20	355	110
CC-20	200	320	500	520	1020	22	420	130
CC-30	320	400	600	700	1300	35	550	150

CODIFICATION: CC - 8

Chocks type C

80kN – Nominal pull

## SMIT Bracket

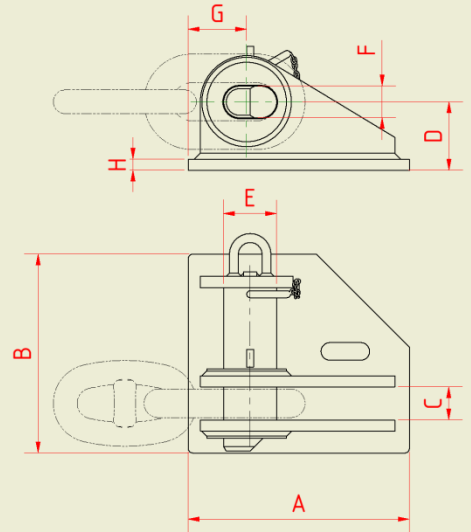
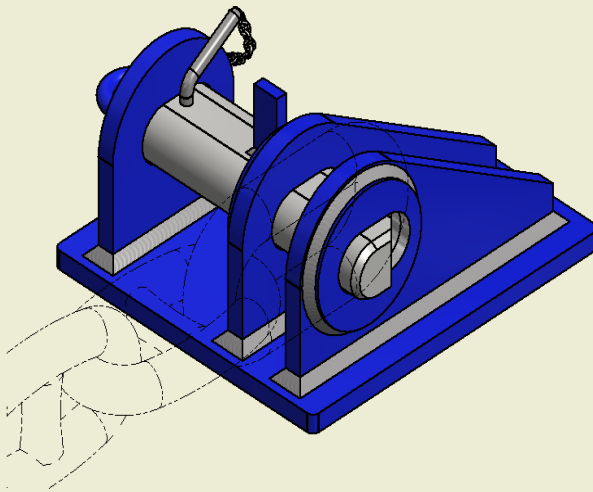

Type	S.W.L (kN)	A	B	C	D	E	F	G	H
SB- 56	1000	450	500	75	155	120	72	140	25
SB-64	1500	600	625	100	225	125	80	173	30
SB-76	2000	720	800	110	240	170	110	205	30

CODIFICATION: SB - 56

SMIT Bracket

Chain size

## END FASTENING

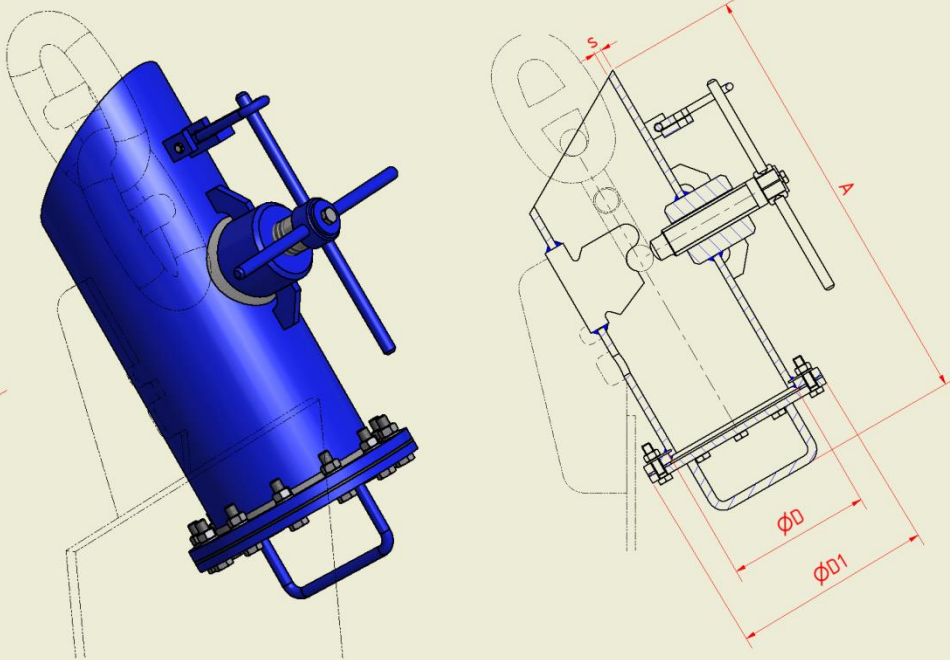

Chain size	Pipe ØD x s	A	ØD1
14 - 34	139,7 x 10	590	215
36 - 46	273 x 12,5	735	375
48 - 56	323 x 14,2	835	440
58 - 68	406 x 16	995	540
70 - 92	508 x 17,5	1245	646
95 - 114	610 x 20	1430	754

CODIFICATION: EF - 34

