



# 1270E



## John Deere 1270E – The most wanted all around harvester

John Deere's E-series wheeled harvesters feature a completely new cabin and TimberMatic automation system. These together provide an operating environment where the operator remains fresh and productive throughout the work shift. The increased rotating and side tilt angles of the cabin, together with the more accurate and smoother movements of the cabin, give the operator greater visibility to the machine's surroundings and make the work more enjoyable. The driving experience is completed with the new cabin's automatic air condition, high-quality upholstery, low noise and vibration levels, and the wide variety of optional features.

The new TimberMatic H-09 measuring and control system includes fully integrated machine diagnostics and bucking instructions, and ensures easy operation of the machine as well as easy setting of the operator specific parameters. In comparison to its predecessor, the John Deere 1270D, the 1270E also enhances productivity by its new CH7 parallel boom which combines higher lifting and slewing torques and excellent durability with great agility for both late thinnings as well as final felling operations. The 1270E's superior

maneuverability is further enhanced by increased ground clearance and higher tractive force.

The 1270E is powered by a 9.0 liter John Deere PowerTech Plus™ engine which is characterized by high torque at low rpm's, thus ensuring excellent fuel efficiency and power for processing large and heavy trees. The exclusive TimberLink™ software enables easy machine performance follow-up and optimization.

All E-series harvesters are equipped with completely new, stronger frames than the corresponding D-series machines. Uptime is enhanced by reduced need for daily and other checks and service actions. The new hydraulic fan reverses automatically cleaning dust and debris out of the engine cooler. The engine air filter includes pre-filtering which multiplies the filter lifetime. An optional central lubrication system further reduces the time spent on daily maintenance.

# 1270E

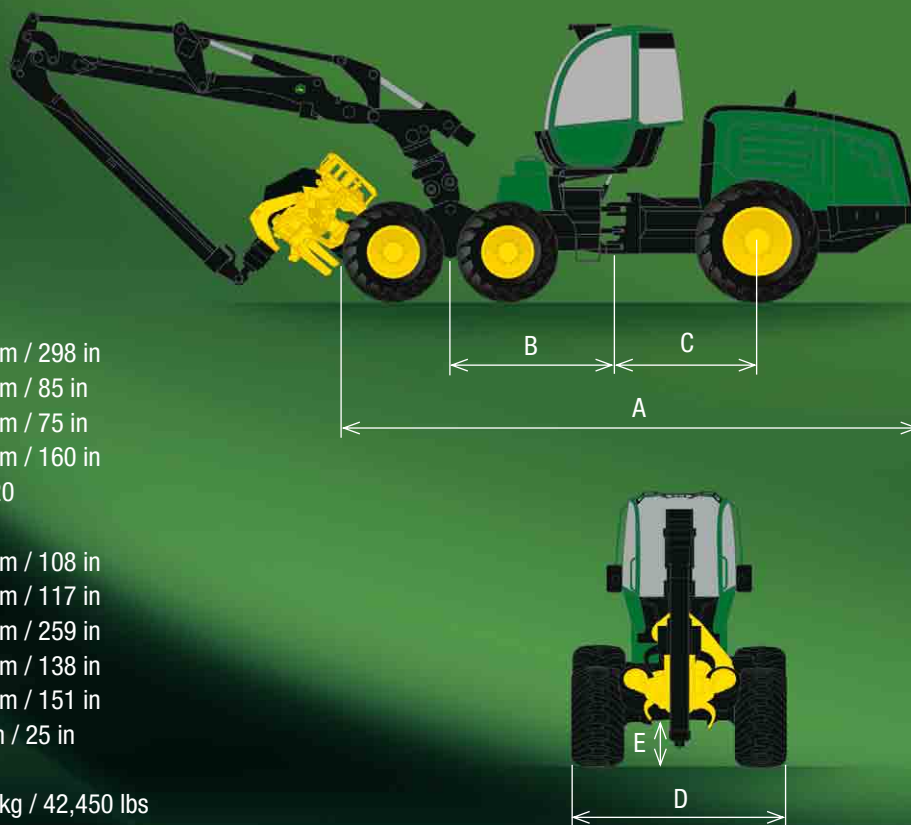

## MEASUREMENTS \*

Length [A]	7550 mm / 298 in
Front axle - middle joint [B]	2150 mm / 85 in
Rear axle - middle joint [C]	1900 mm / 75 in
Wheelbase [B+C]	4050 mm / 160 in
Tyres, front 6W	26,5 - 20
Tyres, rear	34 - 14
Width - 600 series tyres [D]	2750 mm / 108 in
Width - 710 series tyres [D]	2960 mm / 117 in
Outer turning radius - 710 tyres	6570 mm / 259 in
Inner turning radius - 710 tyres	3490 mm / 138 in
Transport height	3830 mm / 151 in
Ground clearance [E]	640 mm / 25 in
Machine weight	
* with H480 harvester head	19,250 kg / 42,450 lbs

\* Note! The measurements are nominal and may vary depending on the manufacturing tolerances.

## BOOM

CH7	
Gross lifting torque	197 kNm / 145,300 lbs. ft
Slewing torque	50 kNm / 36,880 lbs. ft
Max. reach	8.6/10/11.7 m / 28.2 ft/32.8 ft/38.4 ft
Slewing angle	220°
Tilt angle,	
backwards / forwards	-15° / +28°

## HARVESTER HEAD OPTIONS

H754, H414, H752, H480, 758HD, H270

## DIESEL ENGINE

John Deere 6090HTJ	
Turbocharged, charge air cooled	
6 cylinders, displacement 9.0 l	
Max. Engine Power	170 kW (1900 rpm) / 228 hp
Torque	1125 Nm @ 1200-1400 rpm / 830 lbs. ft
Fuel tank	435 l / 115 gal

## WORKING HYDRAULICS

Load-sensing	
Pump size	190 cm <sup>3</sup> / 11.6 in <sup>3</sup>
Working pressure	24/28 MPa / 3480/4060 PSI

## TRANSMISSION

Hydrostatic-mechanical,	
2-speed gear box	
Axles / Bogies	Hydromechanical differential lock at the front and the rear
Front 6W	Balanced portal bogie
Rear	Single rigid axle
Tractive force	175 kN / 39,240 lbs. ft
Steering angle	44°

## CAB

Leveling and rotating (std),	
fixed cab (option)	
Side tilt	0 - 17°
Front/back tilt	0 - 10°
Rotating angle	160°

## MEASURING AND CONTROL

TimberMatic H-09

## OPTIONAL EQUIPMENT

Check availability from your local dealer

This brochure/literature has been compiled with care for worldwide circulation. While general information, pictures and descriptions are provided, some illustrations and text may include options and accessories not available in all regions. Please contact your local dealer for details. John Deere reserves the right to change specification and design for products described in this brochure without notice. No liability for errors and omissions.