

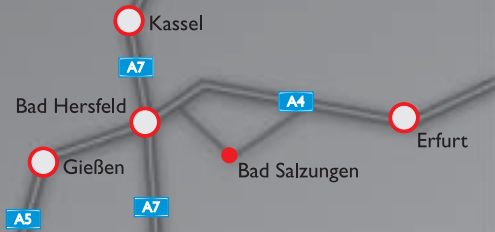

## HAMMEL – in Germany

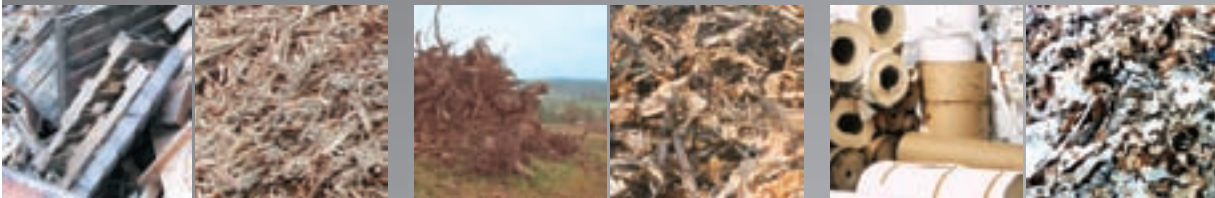

## Bad Salzungen

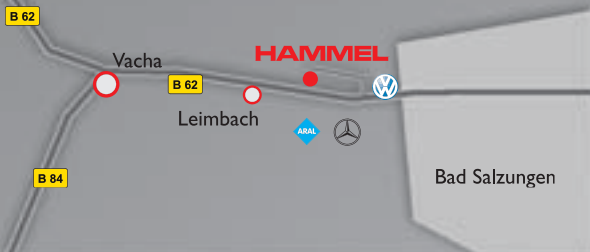

**HAMMEL Recyclingtechnik GmbH**  
Leimbacher Straße 103  
D-36433 Bad Salzungen

phone: +49 (0) 36 95/69 91 - 0  
fax: +49 (0) 36 95/69 91 - 93  
Internet: [www.hammel.de](http://www.hammel.de)  
e-mail: [info@hammel.de](mailto:info@hammel.de)

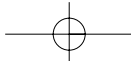



**HAMMEL**  
RECYCLINGTECHNIK



# HAMMEL-Primary Shredder

Type 450/650/750/850/950

Diesel / Electric







# „We proof power” - Technical specifications

The HAMMEL- primary shredder processes extremely difficult materials like waste wood, railway sleepers, root stems, green waste, industrial- and bulky waste, paper rolls, tyres and car bodies, etc. Due to its robust and clear construction the HAMMEL- shredder is reliable for volume reduction. It is equipped with a slow-speed 2-shaft-system. These shafts turn with a speed of approx. max. 46 rpm. Therefore the HAMMEL- shredder belongs to the extremely slow running shredders and has a huge number of advantages

### Engine performances

<b>450 D/DK</b>	140 hp	<b>450 E</b>	110 kW
<b>650 D/DK</b>	280 hp	<b>650 E</b>	160 kW
<b>750 D/DK</b>	350 hp	<b>750 E</b>	260 kW
<b>850 D/DK</b>	480 hp	<b>850 E</b>	320 kW
<b>950 DK</b>	710 hp	<b>950 E</b>	500 kW

### Weights

<b>450 D/E</b>	8 t	<b>450 DK</b>	11 t
<b>650 D/E</b>	16 t	<b>650 DK</b>	19 t
<b>750 D/E</b>	17 t	<b>750 DK</b>	20 t
<b>850 D/E</b>	25 t	<b>850 DK</b>	30 t
<b>950 E</b>	30 t	<b>950 DK</b>	42 t





2  
3

\*approx. values

	working length*	overall length (folded band)*
Type 450:	7,50 m	6,05 m
Type 650:	9,70 m	8,03 m
Type 750:	9,70 m	8,18 m
Type 850:	11,40 m	9,64 m
Type 950:	15,00 m	12,67 m

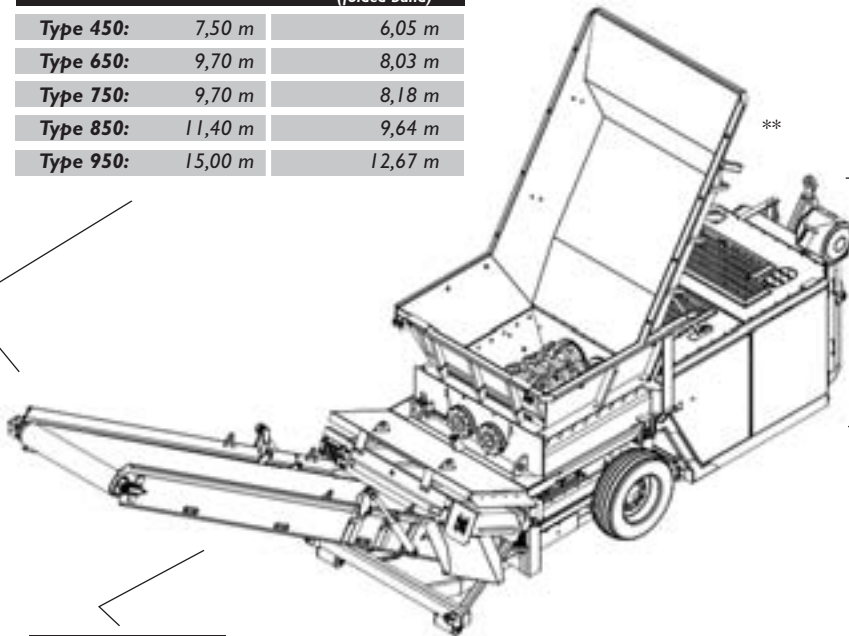

overall height*
Type 450: 2,10 m
Type 650: 2,70 m
Type 750: 2,70 m
Type 850: 3,00 m
Type 950: 3,20 m

overall width*
Type 450: 1,70 m
Type 650: 2,50 m
Type 750: 2,50 m
Type 850: 2,50 m
Type 950: 3,00 m

### ADVANTAGES

- high performance
- very low noise
- minimum of dust generation
- long life time of the shredding tools
- no projectiles
- no fire hazard
- customized
- knives are welded on, not screwed on



\*\*illustration incl. special equipment  
\*\*\*as special equipment available







## The patented „2-shaft system“

The special, counter-rotating shafts with aggressive hooks and knives pull in the material directly loaded onto the shafts. The input material is ripped, torn and cut and discharges directly from the shafts onto the conveyor belt.

When extremely difficult material like carpets and mattresses or root stems are processed and a hydraulic end pressure is reached, the hydraulically controlled shafts switch automatically into reverse. Therefore the shafts turn backwards, and break the material again, clean the shaft from material, switch automatically again into the forward mode and the normal shredding stage can be continued without even being noticed by the operator. This function guarantees that all material was shredded before it enters the discharge conveyor belt, and rolling up of any stringy material is avoided through this special and fully automatic roll up protection.

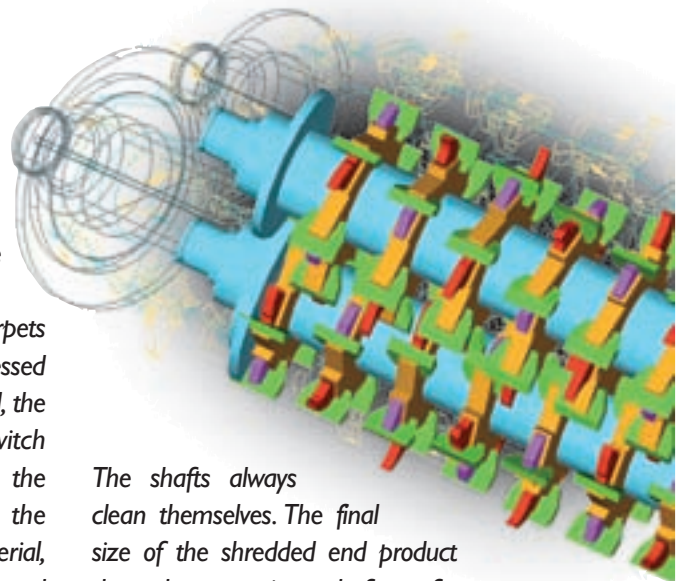

The shafts always clean themselves. The final size of the shredded end product depends on various shaft configurations, HAMMEL can provide you with. Generally, an end product size between approx. 120–500 mm is achieved. Thanks to our long-term experience in the wood and waste sector the shafts have a long life span of more than thousand operating hours before refurbishing is needed.

**The shaft configuration is defined according to the input material and the end product specifications of the customer.**





# All inclusive

Every HAMMEL - primary shredder is equipped with a high quality basic configuration to meet your requirements.

## Basic configuration

### 1. drive

electric or diesel engine

### 2. transportability

stationary build on hook lift frame

### 3. pulling drawbar

provides a fast conversion of the shredder on the factory premises

### 4. low sound emission

noise-reducing construction

### 5. remote control

with different customized functions

### 6. tilting hopper

for ideal feeding

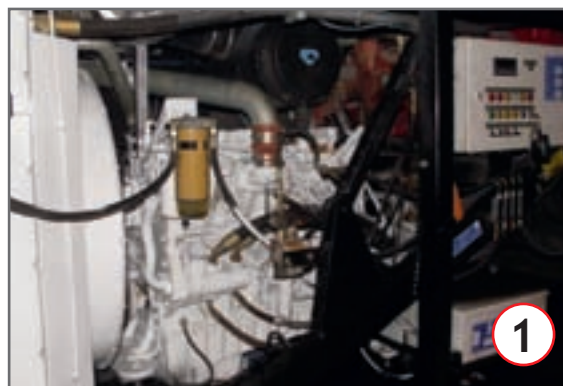





## *We are born in wood!*



*In 1984 the first HAMMEL-machine for shredding root stems was developed. The wood waste recycling market has challenged us until today, so that our shredding technology has been adapted to today's demands and makes the HAMMEL-shredder to a leading primary shredder for all kind of wood in the recycling sector.*

*We pass on our years of experience by finding the most suitable shaft configuration for every customer and needs.*

*Very low wear and tear and energy consumption as well as high performances are reached by sophisticated engineering and perfectly matching shafts.*



***Innovation - Experience - Economy - Satisfaction***





# Performance Characteristics

Recyclingmaterial	HAMMEL Shredder Type				
	primary shredder*				
	450 D/E	650 D/E	750 D/E	850 D/E	950 D/E
wood waste/demolition wood	10 t/h	30 t/h	60 t/h	120 t/h	230 t/h
pallets	8 t/h	25 t/h	50 t/h	90 t/h	200 t/h
mixed wood	12 t/h	30 t/h	60 t/h	100 t/h	190 t/h
cable drums	6 t/h ***	25 t/h	40 t/h	60 t/h	130 t/h
railway sleepers		15 t/h	25 t/h	50 t/h	70 t/h
telephone poles		15 t/h	25 t/h	50 t/h	70 t/h
root stems	8 t/h **	25 t/h	40 t/h	50 t/h	90 t/h
green waste	15 t/h	25 t/h	50 t/h	80 t/h	120 t/h

\* performances until approx.  
 \*\* up to Ø 400 mm  
 \*\*\* up to Ø 1.000 mm

With a HAMMEL-primary shredder an end product size between 120 mm – 500 mm can be reached depending on the selected shaft configuration.







## *„Contact us before you drown in waste!”*



*At the beginning of the 90's the HAMMEL-shredder has been modified according to the demands of the waste-shredding sector. Due to our long term experience in processing of different kinds of waste the HAMMEL-shredder was developed further to one of, if not the market leader.*



*Various shaft configurations make it possible that the input materials are pre-shredded to the requested end product size. Our HAMMEL-primary shredders find its use in incineration plants - for fuel production and as primary shredders before sorting lines or just for volume reduction. The input material is pre-shredded to a homogeneous end product by the 2-shaft-system and is therefore perfectly prepared for further applications.*

**Volume Reduction - Renewable Energy - Profit**

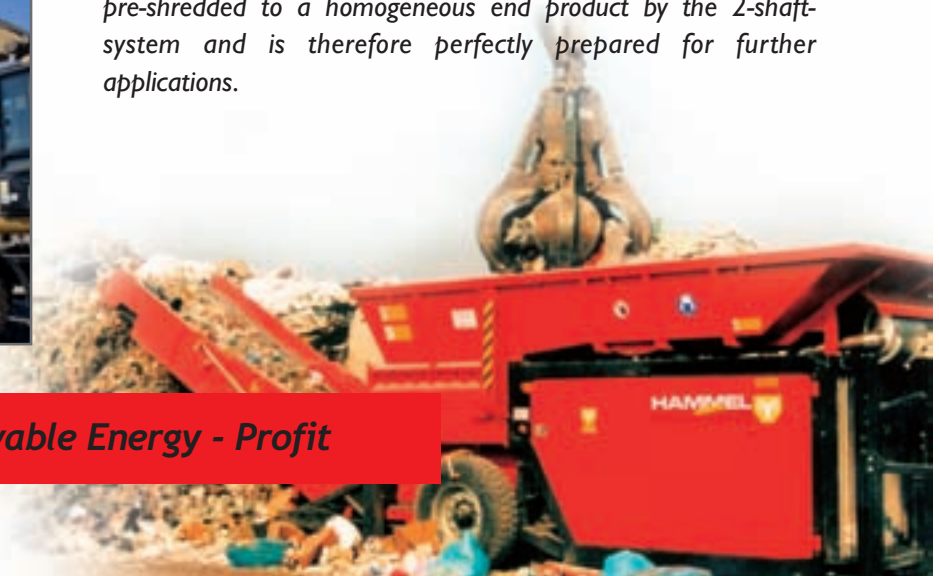





# Performance Characteristics

Recyclingmaterial	HAMMEL Shredder Type				
	primary shredder*				
	450 D/E	650 D/E	750 D/E	850 D/E	950 D/E
domestic waste	10 t/h	20 t/h	50 t/h	100 t/h	200 t/h
industrial/commercial waste			45 t/h	80 t/h	150 t/h
bulky waste			30 t/h	60 t/h	110 t/h
C&D			35 t/h	80 t/h	150 t/h
paper		10 t/h	20 t/h	45 t/h	70 t/h
paper rolls		10 t/h	15 t/h	30 t/h	60 t/h
used tyres			20 t/h	30 t/h	50 t/h
aluminium profiles	5 t/h		12 t/h	20 t/h	40 t/h
car bodies					50 t/h
high caloric fuels 150 mm			20 t/h	30 t/h	70 t/h

\* performances up to approx.

With a HAMMEL-primary shredder an end product size between 120 mm - 500 mm can be reached depending on the selected shaft configuration.





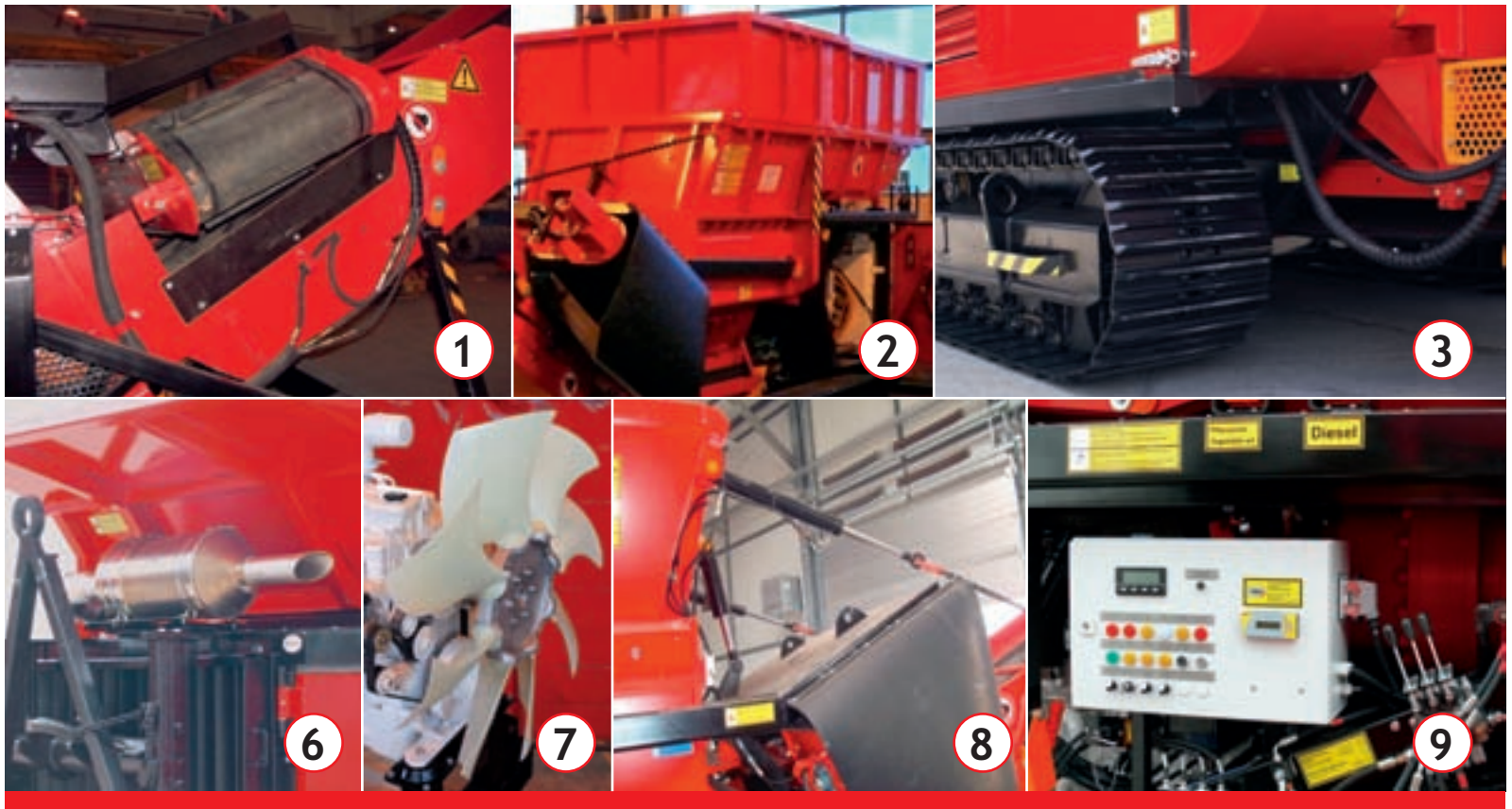

## *Our innovations - Your choice*





5



5

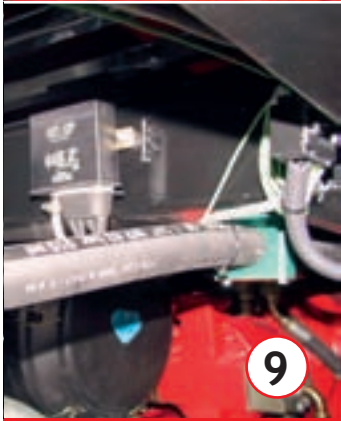

9



10



11

## Options

### 1. metal separation

permanent- over belt magnet that selects ferrous metal parts

### 2. hopper extension

a higher volume avoids the dropping of the input material

### 3. chassis

stationary, wheel axle, track system

### 4. breaker bar

with and without combs or breaker basket, to produce a smaller end product

### 5. water sprinkling system

for dust minimisation

### 6. particulate filter

for all diesel machines

### 7. sickle fan

provides additional noise reduction

### 8. hydraulically height adjustment of the discharge belt

for a perfect adjustment of the discharge height for optimising of the discharge quantity

### 9. alternative fuel

alteration for use of bio-diesel, rape oil, etc.

### 10. special painting

according to your company colour

### 11. stone crusher specification

for the shredding of stones and concrete ties



4



4



4

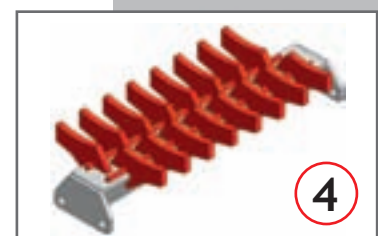

4