

Mini Chain Hoist & Mini Lever Hoist

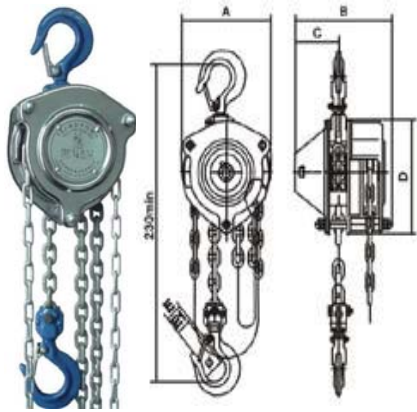

Model: **TSJ-C**

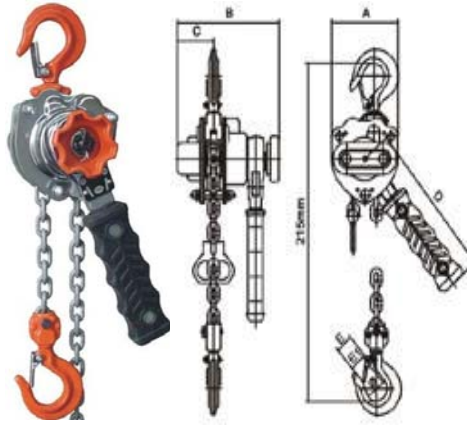

Model: **QYJ-A**

Feature

- » Light weight, small volume.
- » Super quality steel frame, chromed gear case and cover.
- » Hoists tested at 150% of load capacity prior to shipment.
- » Swivel hooks in special steel with safety latch.
- » High quality Grade 80 zinc plated chain.

Model	Load capacity (T)	Lift (m)	Test Load (kN)	Pulling force to lift full load (N)	No. of load chain	Dia. Of load chain (mm)	Dimension (mm)							N.W. (kg)
							A	B	C	D	E	E1	E1Φ	
TSJ-C	0.25	2	3.7	114	1	Φ4	100	100	49	109	18	15.5	25	3.5
QYJ-A	0.25	1	3.06	125	1	Φ4	75	116	41	157	18	15.5	25	2
QYJ-A	0.5	1.5	6.12	180	1	Φ5	90	135	52	180	24	21	32	3.5

Wire Rope Hoist

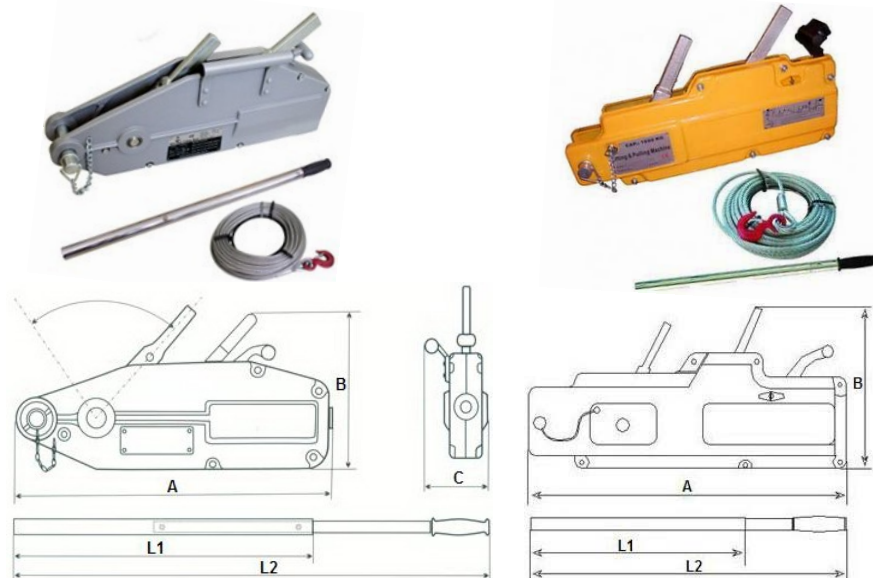

Feature

- » Versatile and portable unit for pulling, lifting, dragging and stretching applications over long distances.
- » Built-in shear pins for overload protection.
- » Telescopic handle for easy carry and operation.
- » Standard capacity & wire rope: rated load from 0.8ton to 5.4ton, with standard wire rope length of 20M.
- » Low operation and maintenance requirements.

Option

- » Swivel hook is available for model **WRH**.
- » Longer rope available.
- » Color available: grey, yellow.

Model: **WRH** (aluminum body)

Model: **WRH-B** (iron body)

Model	WRH-800	WRH-1600	WRH-3200	WRH-5400	WRH-800B	WRH-1600B	WRH-3200B
Lifting Capacity (kg)	800	1600	3200	5400	800	1600	3200
Max Travelling Load (kg)	1200	2400	4000	8000	1200	2400	4000
Rated Forward Handpower (N)	343	441	441	745	343	441	441
Rated Forward Travel (mm)	≥52	≥55	≥28	≥30	≥52	≥55	≥28
Rope Diameter (mm)	8.3	11	16	20	8.3	11	16
Safety Factor for Wire Rope	5	5	5	5	5	5	5
Safety Factor for Static Loading	5	5	5	5	5	5	5
Dimensions	A (mm)	426	545	660	932	426	545
	B (mm)	235	280	325	420	235	280
	C (mm)	64	97	116	300	64	97
	L1 (cm)	-	80	80	88	88	80
	L2 (cm)	80	120	120	136	136	120