

ORSAY 2

Code 300122

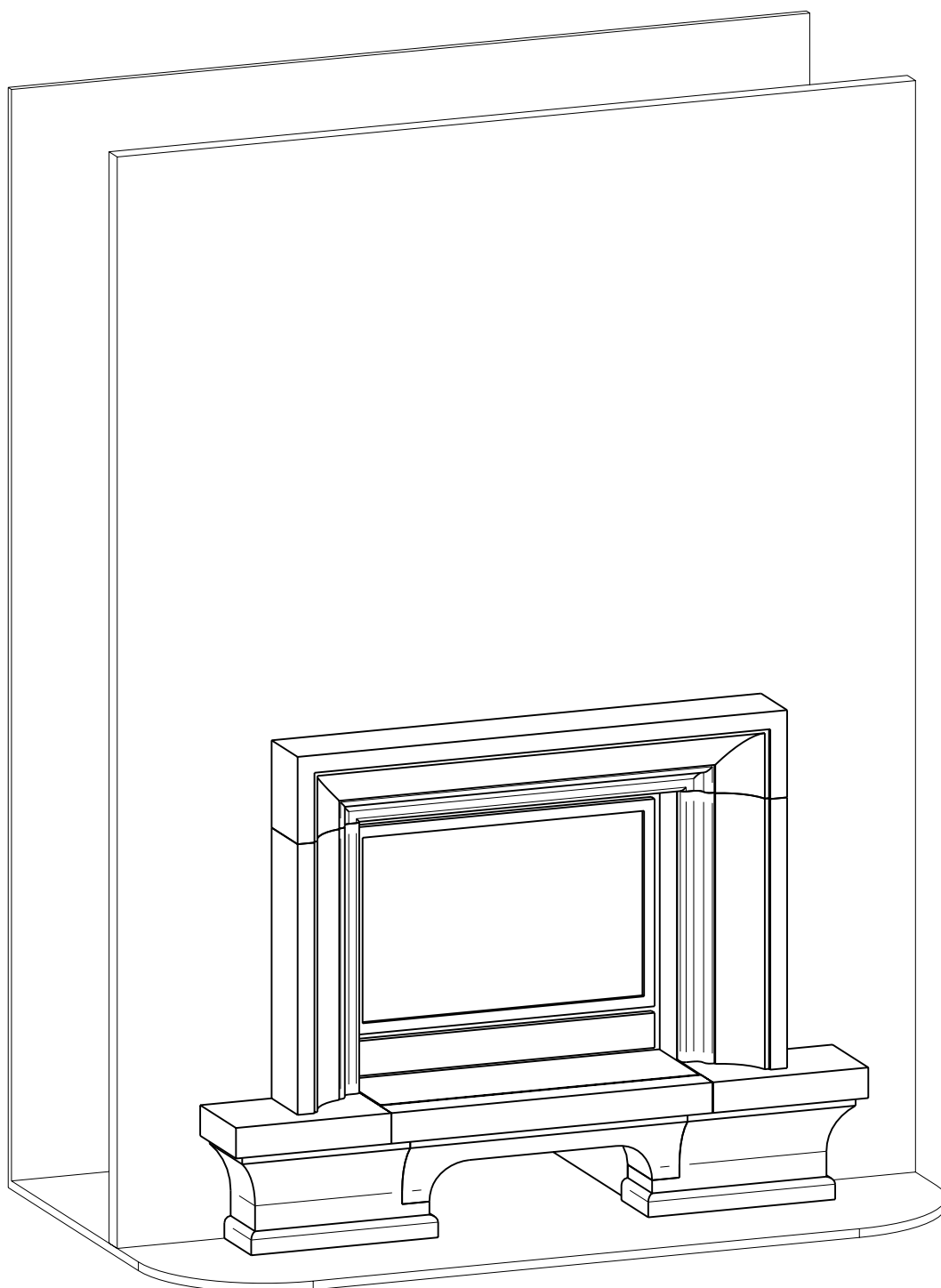

CE DOCUMENT N'EST PAS CONTRACTUEL, LE FABRICANT SE RESERVE LE DROIT DE MODIFIER SES MODELES SANS PREAVIS

Plan d'implantation / Layout drawing / Einbauplan

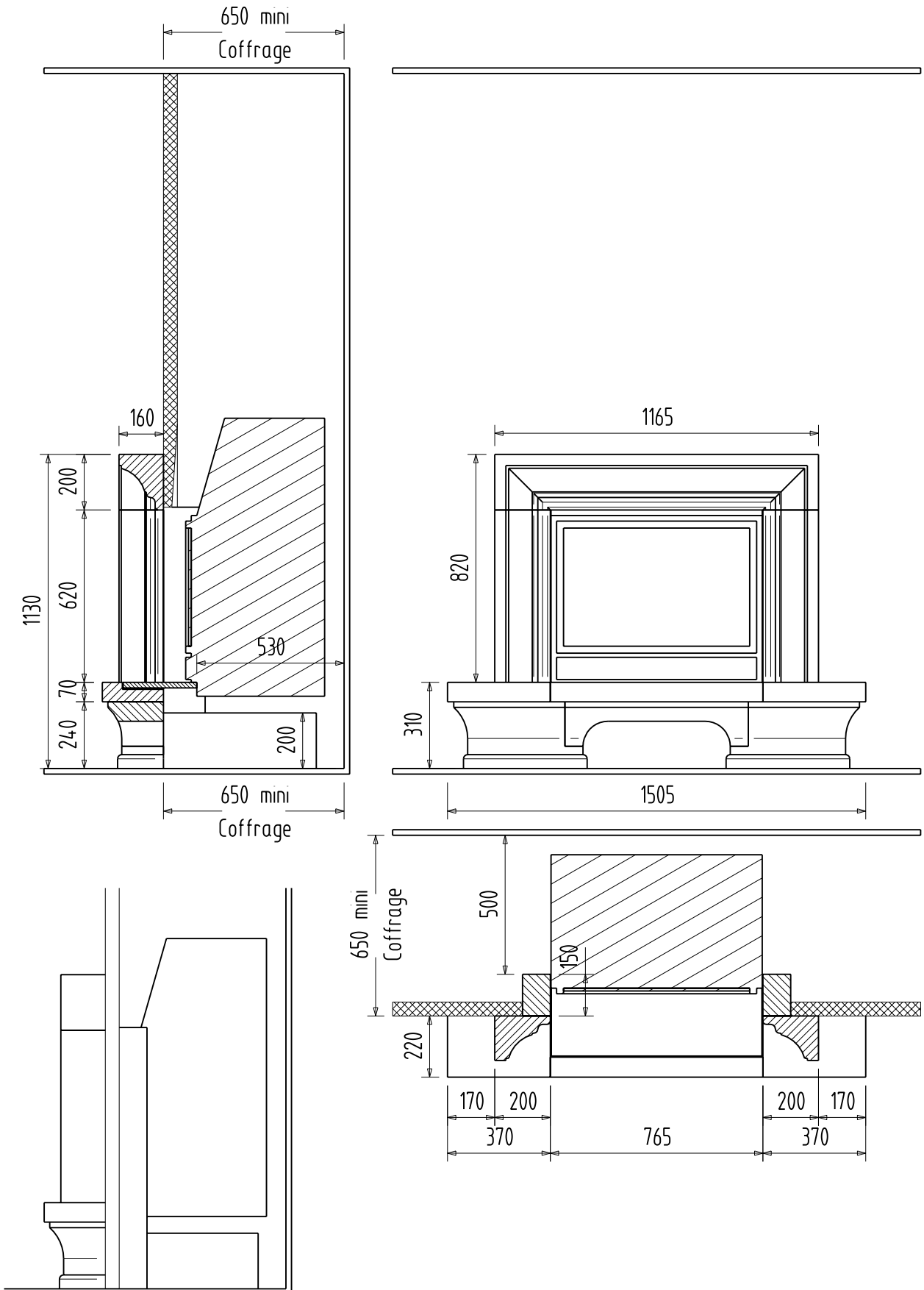

Poids de l'habillage / Fireplace weight / Gewicht des Steinbausatzes : 358 kg

CE DOCUMENT N'EST PAS CONTRACTUEL, LE FABRICANT SE RESERVE LE DROIT DE MODIFIER SES MODELES SANS PREAVIS

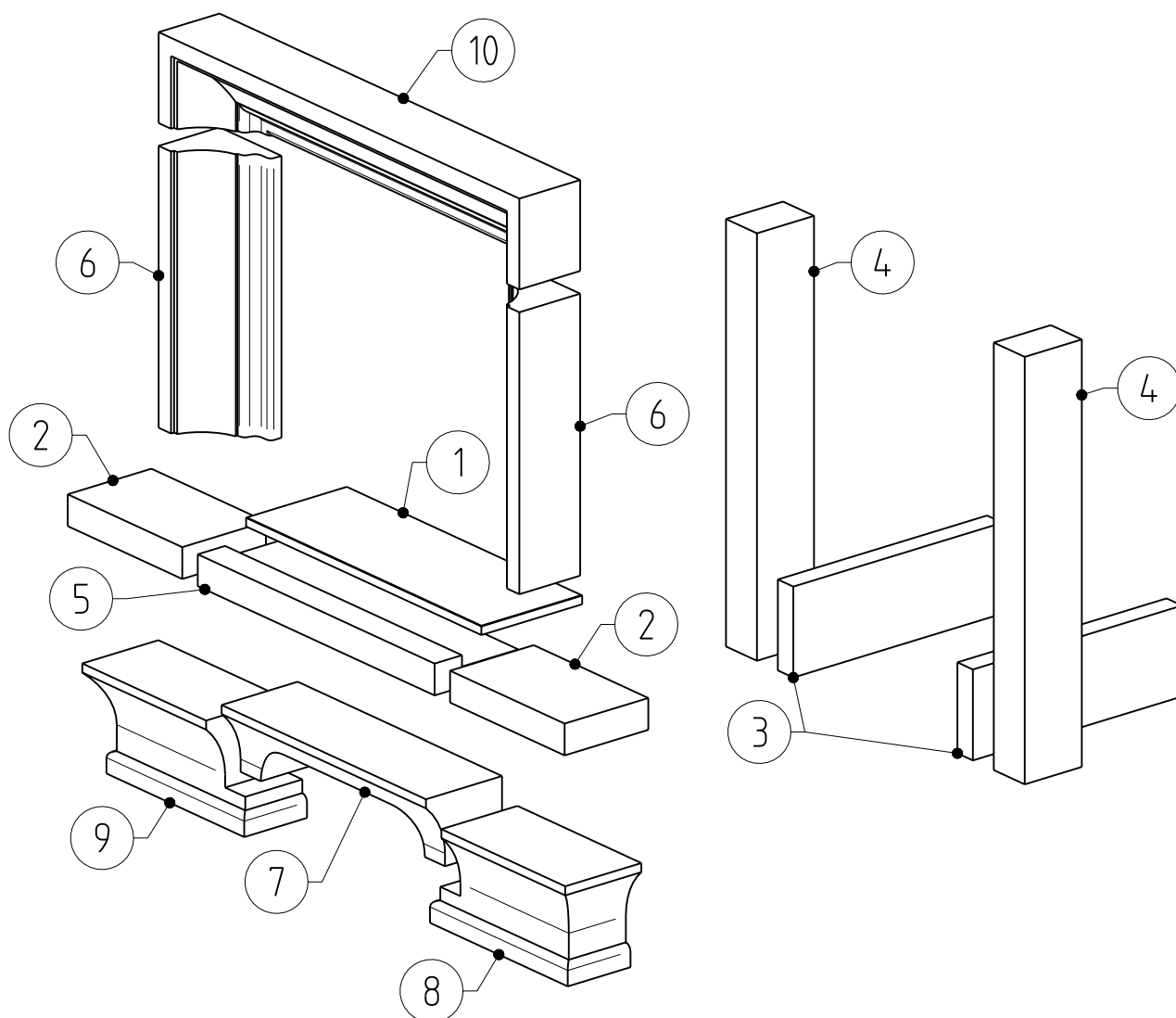

Item	Qty	Reference	no	Material	Dimensions	kg
1	1	gd0760265020a		Marbre / Marble / Marmor	760x265x20	11
2	2	ra0370220070x		Edelroc	370x220x70	13
3	2	ra0550200050x		Edelroc	550x200x50	13
4	2	ra0940150100x		Edelroc	940x150x100	33
5	1	rb0765220070x		Edelroc	765x220x70	21
6	2	rs0620200160x		Edelroc	620x200x160	27
7	1	rs0660200160x		Edelroc	660x200x160	26
8	1	rw0480240200d		Edelroc	480x240x200	36
9	1	rw0480240200g		Edelroc	480x240x200	36
10	1	rw1165200160x		Edelroc	1165x200x160	56

Phases de montage / Phases of assembly / Aufbauphasen

PHASE 1

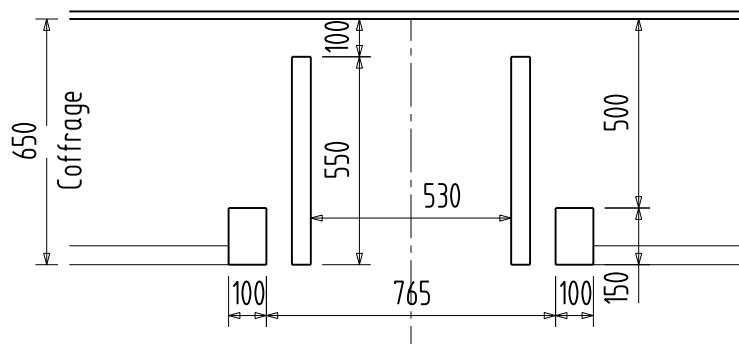

PHASE 2

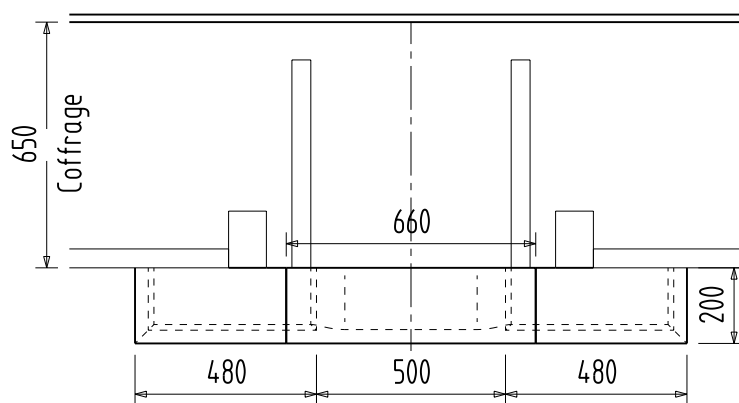

PHASE 3

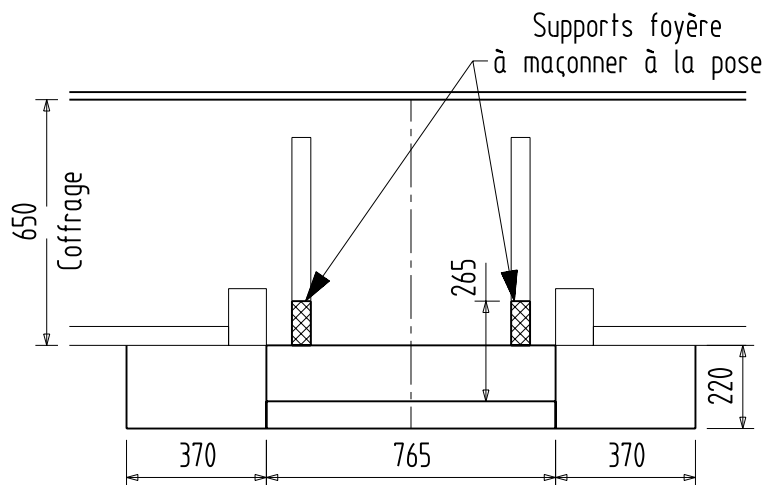

PHASE 4

