

grande
brio



ecoray
ecoray

INNOVATION IN CLEANING EQUIPMENT
TSM

35 B & (E)

75 - 650

Pista di pulizia / Scrubbing path	mm	350	650
Larghezza tergipavimento / Squeegee width	mm	420	750
Rendimento orario / Coverage performance	m ² /h	1050	3250
Tempo di lavoro / Working time	h	> 1h 30', (∞)	> 3h
Serbatoio soluzione-recupero / Solution-Recovery tank	l	16 / 18	75 / 85
Diametro spazzole / Brush size	mm	1 x 350	4 x 180
Motore spazzole / Brush motor	W, V	1 x 250	4 x 100, 24
Pressione spazzole / Brush pressure	kg	28	28
Motore trazione / Traction motor	W, V	//	700, 24
Motore aspirazione / Vacuum motor	W, V	2 stages 200 (210), 12 (220)	3 stages 530, 24
Potenza sistema Ecoray® / Ecoray® system power	µW/cm ²	100	100
Durata emettitore / Life time UV source	h	9000	9000
Batterie (DIN) / Battery capacity (DIN)	A (5h)	65 (Gel), (//)	150 (Wet)
Comparto batterie (L x L x H) / Batt. comp. (L x W x H)	mm	290 x 190 x 235, (//)	400 x 420 x 325
Caricabatterie / Battery charger	A/h	8 (on board), (//)	20
Peso senza (con) batterie / Weight without (with) batteries	kg	40 (63,5)	158 (235)
Dimensioni (L x L x H) / Dimensions (L x W x H)	mm	770 x 460 x 645	1150 x 780 x 1300

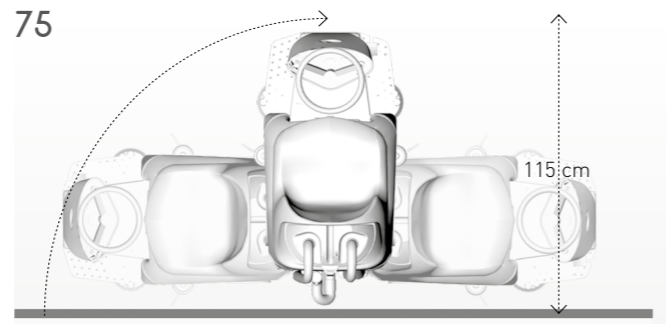
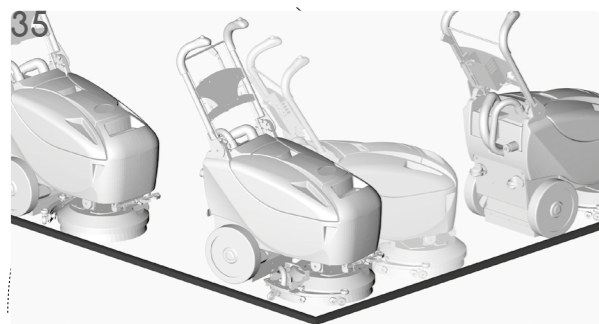

ecoray®

è il sistema di sterilizzazione integrato che permette l'eliminazione del 99% dei batteri presenti sul pavimento, senza utilizzare detergenti

is the integrated sterilization system that allows the elimination of 99% of bacteria presented on the floor, without using chemicals



It's time to step forward and face the world's challenge. It's time for GRANDE BRIO

The conquest of simplicity



TSM - Technological Systems by Moro Srl

Via Fratelli Zambon, 9 - 33080 Fiume Veneto (PN) - Italy

Tel. +39.0434.564167 - Fax +39.0434.954069

www.tsmitaly.com - marketing@tsmitaly.com

 - [tsmitaly](https://www.youtube.com/tsmitaly) -

INNOVATION IN CLEANING EQUIPMENT

TSM

