

Smart rear view system brings you a safer life!

## 5" rear view system with parking sensors

- Intellectual step-by-step voice-directed alarm system
- Automatic backlighting for buttons
- Mirror and Normal switch available
- Operates from 12V~32V
- 11 languages for user operation
- 3 AV inputs
- Earphone jack
- Auto switch to back-up, left or right side camera view

**MO-II2, CW-085, PS-A01**



## Specifications

Camera	
Image Device	1/3" COLOR SHARP CCD
TV System	PAL/NTSC
Resolution(TV Lines)	420
Minimum Illumination(Lux/F1.2)	0
Effective Pixels	512 x 582 pixels / 512 x 492 pixels
Input voltage (VDC)	12
Monitor	
Image Device	5" Color TFT LCD
Dot Pitch	0.321(H) x 0.3185(V)
Resolution	960(H) x 234(V)
Contrast	350:1
Brightness	400cd/m <sup>2</sup>
View Angle	U: 15 / D:35, R/L:50

## Application

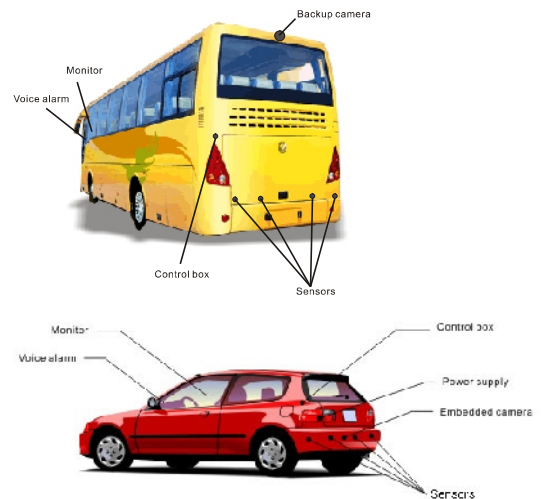

## Dimensions

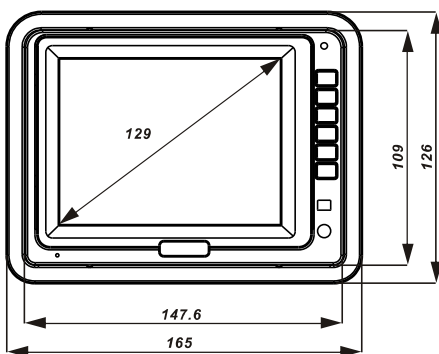

Unit: mm

## Connection

