

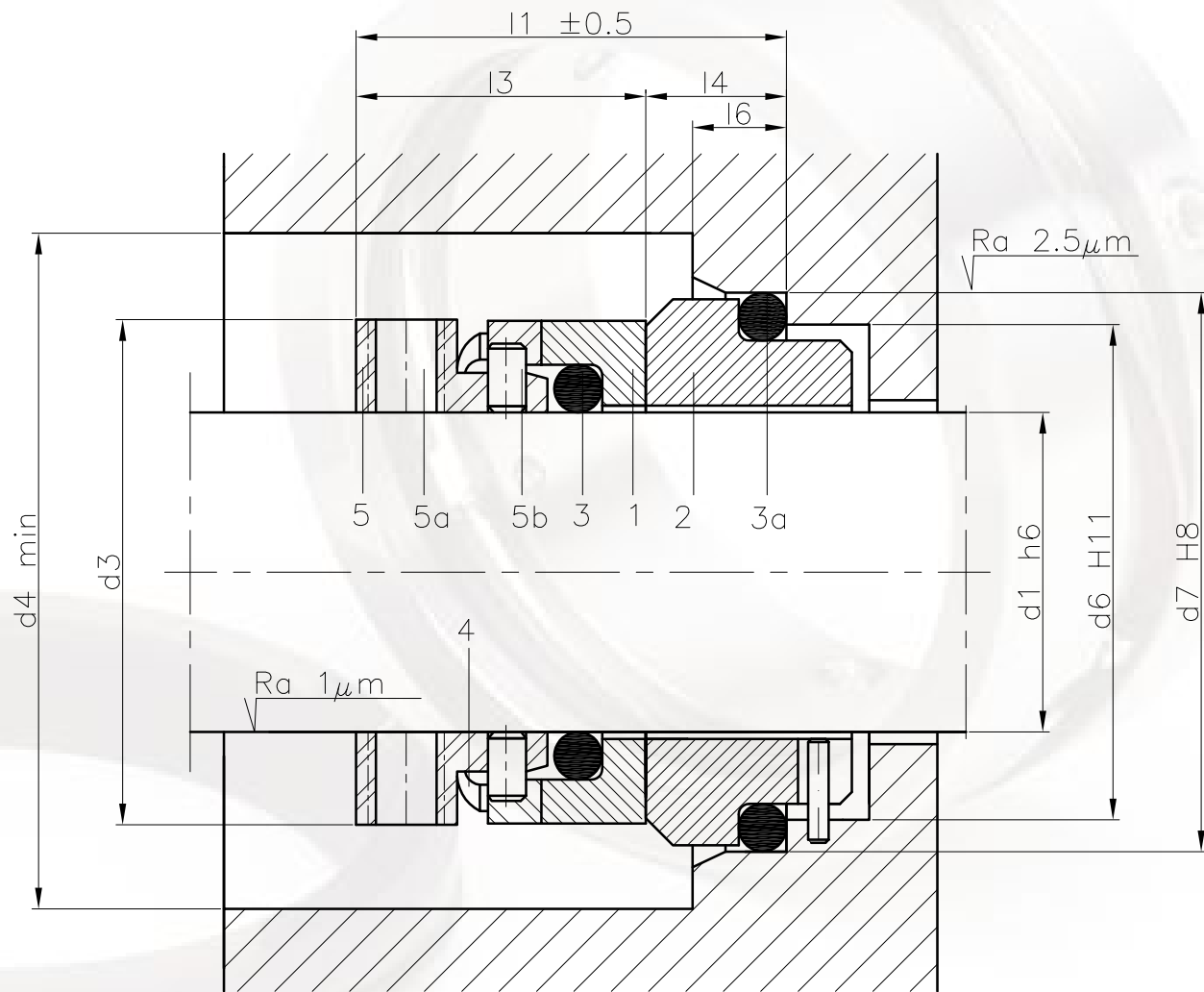

LIDE RING

GARNITURES MÉCANIQUES 271



Garnitures Mécaniques 271

Garniture mécanique de longueur axiale très réduite. Montage interne ou externe. Sens de rotation indépendant.



TABLEAU DIMENSIONNEL (Dimensions en mm. sujettes à variations ou modifications)

Ref.	d ₁	d ₃	d ₄	d ₆	d ₇	d ₈	l ₁	l ₃	l ₄	l ₆
16	16	27	31	27	27	3	27.7	19.1	8.6	7
18	18	29	33	27	33	3	29.1	19.1	10.0	9
20	20	32	36	29	35	3	29.1	19.1	10.0	9
22	22	34	38	31	37	3	29.1	19.1	10.0	9
24	24	34	38	33	39	3	29.1	19.1	10.0	9
25	25	35	39	34	40	3	29.1	19.1	10.0	9
28	28	40	44	37	43	3	29.1	19.1	10.0	9
30	30	41	45	39	45	3	29.1	19.1	10.0	9
32	32	43	47	42	48	3	29.1	19.1	10.0	9
33	33	44	48	42	48	3	29.1	19.1	10.0	9
35	35	46	50	44	50	3	29.1	19.1	10.0	9
38	38	52	56	49	56	4	32.1	21.1	11.0	10
40	40	55	59	51	58	4	32.1	21.1	11.0	10
43	43	58	62	54	61	4	32.1	21.1	11.0	10
45	45	60	64	56	63	4	32.1	21.1	11.0	10
48	48	62	66	59	66	4	32.1	21.1	11.0	10
50	50	62	66	62	70	4	34.1	21.1	13.0	11
53	53	71	75	65	73	4	34.1	22.1	13.0	11
55	55	72	76	67	75	4	34.1	22.1	13.0	11
58	58	78	82	70	78	4	38.8	25.8	13.0	11
60	60	79	83	72	80	4	38.8	25.8	13.0	11
63	63	79	83	75	83	4	38.8	25.8	13.0	11
65	65	87	91	77	85	4	38.8	25.8	13.0	11
68	68	89	93	81	90	4	41.1	25.8	15.3	12
70	70	89	93	83	92	4	41.1	25.8	15.3	12
75	75	96	100	88	97	4	41.1	25.8	15.3	12
80	80	101	105	95	105	4	41.5	25.8	15.7	13
85	85	108	112	100	110	4	41.5	25.8	15.7	13
90	90	113	117	105	115	4	41.5	25.8	15.7	13
95	95	116	120	110	120	4	41.5	25.8	15.7	13
100	100	121	125	115	125	4	41.5	25.8	15.7	13

LIMITES D'UTILISATION

d₁ = 16 ÷ 100 mm

p = 10 Kg/cm²

v = 15 m/s

t = -20 ÷ +200°C

Les limites d'utilisation ci-dessus peuvent varier en fonction du facteur PV

CONSTRUCTION

1 Grain mobile

2 Grain stationnaire

3 Joint torique

3a Joint torique

4 Ressort

5 Corps

5a Vis d'attache

5b Goupille (anti-rotation)

MATERIAUX

GBPGG

QBPGG

QQPGG

GBVGG

QBVGG

QQVGG

GBEGG

QBEGG

QQEGG

Il existe d'autres combinaisons de matériaux

LIDERING

LIDERING, S.A.

Pg. Ferrocarrils Catalans, 106-108 · 08940 Cornellà de Llobregat BARCELONA

Service Ventes Nationales: 902 480 440

Service Ventes Internationales: +34 93 480 44 22

Fax 93 480 44 04



Pollensa, 2, Ofic. 8. Edif. Artemisa - Tartessos

28290 Las Rozas MADRID

Tel. 902 480 440 · Fax 91 361 40 20

LIDERING S.A.R.L.

Parc des Aqueducs · Chemin du Favier RD 42 · 69230 Saint-Genis-Laval FRANCE

Tél. 04 72 67 02 67 - Fax 04 78 56 04 08

S.A. LIDERING N.V.

BP 10 · 1410 Waterloo BELGIQUE-BELGIË

Tél. 00 34 93 480 44 22 - Fax 00 34 93 480 44 04

<http://www.lidering.com>

email: info@lidering.com