

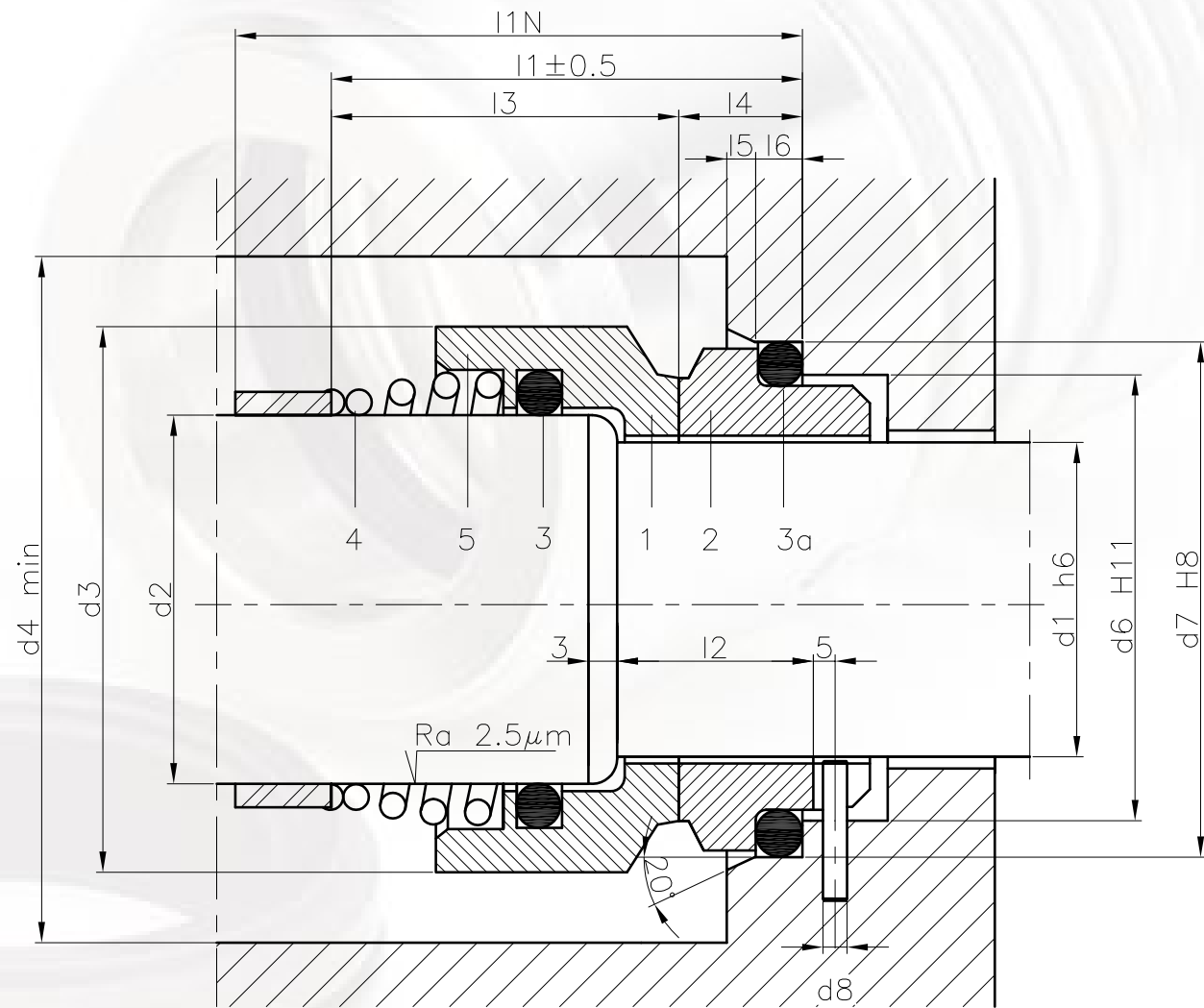

LIDER **ING**

GARNITURES MECÁNIQUES 600 B DIN



Garnitures Mécaniques 600 B DIN

Garniture mécanique équilibrée,
ressort simple, sens
de rotation dépendant.



TABLEAU DIMENSIONNEL (Dimensions en mm. sujettes à variations ou modifications)

Ref.	d ₁	d ₂	d ₃	d ₄	d ₆	d ₇	d ₈	l _{1N}	l ₁	l ₂	l ₃	l ₄	l ₅	l ₆
10	10	14	24	26	17	21	3	50	50	18	43	7	1.5	4
12	12	16	26	28	19	23	3	50	50	18	43	7	1.5	4
14	14	18	32	34	21	25	3	55	46	18	39	7	1.5	4
16	16	20	34	36	23	27	3	55	47	18	40	7	1.5	4
18	18	22	36	38	27	33	3	55	51	20	41	10	2.0	5
20	20	24	38	40	29	35	3	60	53	20	43	10	2.0	5
22	22	26	40	42	31	37	3	60	53	20	43	10	2.0	5
24	24	28	42	44	33	39	3	60	60	20	50	10	2.0	5
25	25	30	44	46	34	40	3	60	60	20	50	10	2.0	5
28	28	33	47	49	37	43	3	65	65	20	55	10	2.0	5
30	30	35	49	51	39	45	3	65	65	20	55	10	2.0	5
32	32	38	54	58	42	48	3	65	65	20	55	10	2.0	5
33	33	38	54	58	42	48	3	65	65	20	55	10	2.0	5
35	35	40	56	60	44	50	3	65	65	20	55	10	2.0	5
38	38	43	59	63	49	56	4	75	75	23	62	13	2.0	6
40	40	45	61	65	51	58	4	75	75	23	62	13	2.0	6
43	43	48	64	68	54	61	4	75	75	23	62	13	2.0	6
45	45	50	66	70	56	63	4	75	75	23	62	13	2.0	6
48	48	53	69	73	59	66	4	85	85	23	72	13	2.0	6
50	50	55	71	75	62	70	4	85	85	25	71	14	2.5	6
53	53	58	78	83	65	73	4	85	85	25	71	14	2.5	6
55	55	60	80	85	67	75	4	85	85	25	71	14	2.5	6
58	58	63	83	88	70	78	4	85	85	25	71	14	2.5	6
60	60	65	85	90	72	80	4	95	95	25	81	14	2.5	6
63	63	68	88	93	75	83	4	95	95	25	81	14	2.5	6
65	65	70	90	95	77	85	4	95	95	25	81	14	2.5	6
70	70	75	99	104	83	92	4	95	95	28	79	16	2.5	7
75	75	80	104	109	88	97	4	105	105	28	89	16	2.5	7
80	80	85	109	114	95	105	4	105	105	28	87	18	3.0	7
85	85	90	114	119	100	110	4	105	105	28	87	18	3.0	7
90	90	95	119	124	105	115	4	105	105	28	87	18	3.0	7
95	95	100	124	129	110	120	4	105	105	28	87	18	3.0	7
100	100	105	129	134	115	125	4	105	105	28	87	18	3.0	7

LIMITES D'UTILISATION

d₁ = 10 ÷ 100 mm

p = 50 Kg/cm²

v = 20 m/s

t = -70 ÷ +200°C

Les limites d'utilisation ci-dessus peuvent varier en fonction du facteur PV

MATERIAUX

F₁BPGF₁

GBPGG

F₁B₂PGF₁

UUPGF

QQPGF

CONSTRUCTION

1 Grain mobile

2 Grain stationnaire

3 Joint torique

3a Joint torique

4 Ressort

5 Corps

Il existe d'autres combinaisons de matériaux

LIDERING

LIDERING, S.A.

Pg. Ferrocarrils Catalans, 106-108 · 08940 Cornellà de Llobregat BARCELONA

Service Ventes Nationales: 902 480 440

Service Ventes Internationales: +34 93 480 44 22

Fax 93 480 44 04



Pollensa, 2, Ofic. 8. Edif. Artemisa - Tartessos

28290 Las Rozas MADRID

Tel. 902 480 440 · Fax 91 361 40 20

LIDERING S.A.R.L.

Parc des Aqueducs · Chemin du Favier RD 42 · 69230 Saint-Genis-Laval FRANCE

Tél. 04 72 67 02 67 - Fax 04 78 56 04 08

S.A. LIDERING N.V.

BP 10 · 1410 Waterloo BELGIQUE-BELGIË

Tél. 00 34 93 480 44 22 - Fax 00 34 93 480 44 04

<http://www.lidering.com>

email: info@lidering.com