

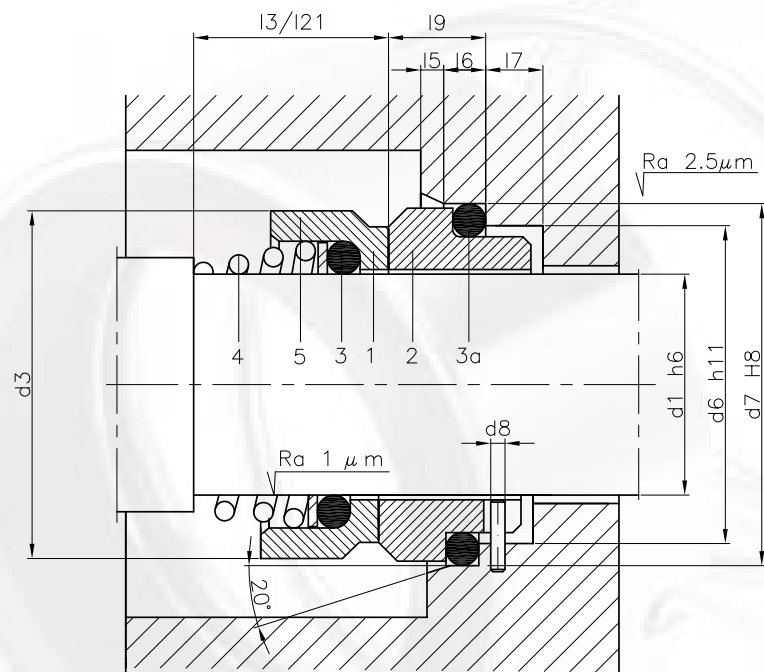

**LIDE RING**

GARNITURES MECÁNIQUES 108 / 109



## Garnitures Mécaniques 108 / 109

Garniture mécanique non  
équilibrée, ressort simple, sens  
de rotation dépendant.



### Profils de Grains Fixes

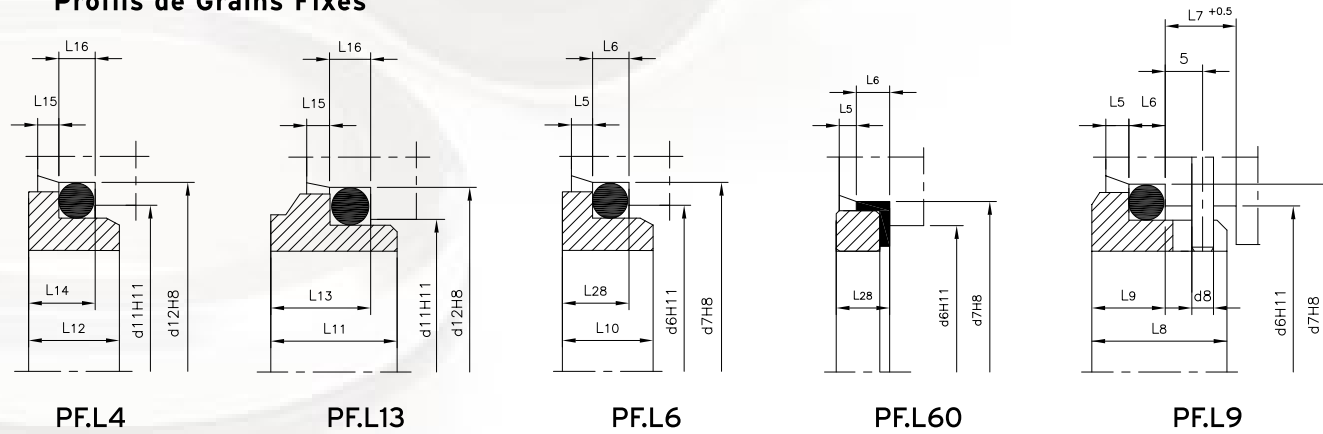

Type 108: longueur de montage de la partie tournante  $l_3$   
Type 109: longueur de montage de la partie tournante  $l_{21}$

### LIMITES D'UTILISATION

$d_1$  = 10 ÷ 80 mm  
 $p$  = 10 Kg/cm<sup>2</sup>  
 $v$  = 20 m/s  
 $t$  = -20 ÷ +200°C

Les limites d'utilisation ci-dessus peuvent varier  
en fonction du facteur PV

### MATERIAUX

GBPGG  
BGP GG  
BQP GG  
QQP GG  
UUP GG  
BVP GG

### CONSTRUCTION

1	Grain mobile
2	Grain stationnaire
3	Joint torique
3a	Joint torique
4	Ressort
5	Corps

Il existe d'autres combinaisons  
de matériaux

TABLEAU DIMENSIONNEL (Dimensions en mm. sujettes à variations ou modifications)

Ref.	$d_1$	$d_3$	$d_6$	$d_7$	$d_8$	$d_{11}$	$d_{12}$	$l_3$	$l_5$	$l_6$	$l_7$	$l_8$	$l_9$	$l_{10}$	$l_{11}$	$l_{12}$	$l_{13}$	$l_{14}$	$l_{15}$	$l_{16}$	$l_{21}$	$l_{28}$
10	10	19	17	21	3	15.5	19.2	15.5	1.5	4	8.5	17.5	10.0	7.5	9.0	7.5	7.1	6.6	1.2	3.8	15.5	6.6
12	12	21	19	23	3	17.5	21.6	16.0	1.5	4	8.5	17.5	10.0	7.5	10.0	6.5	7.6	5.6	1.2	3.8	15.5	6.6
14	14	23	21	25	3	20.5	24.6	16.5	1.5	4	8.5	17.5	10.0	7.5	10.0	6.5	7.6	5.6	1.2	3.8	15.5	6.6
15	15	24	--	--	--	20.5	24.6	--	--	--	--	--	--	11.0	7.5	8.6	6.6	1.2	3.8	15.5	--	
16	16	26	23	27	3	22.0	28.0	18.0	1.5	4	8.5	17.5	10.0	7.5	11.5	8.5	9.0	7.5	1.5	5.0	17.5	6.6
18	18	29	27	33	3	24.0	30.0	19.5	2.0	5	9.0	19.5	11.5	8.5	12.5	9.0	10.0	8.0	1.5	5.0	18.5	7.5
20	20	31	29	35	3	29.5	35.0	22.0	2.0	5	9.0	19.5	11.5	8.5	12.5	8.5	9.5	7.5	1.5	5.0	20.0	7.5
22	22	33	31	37	3	29.5	35.0	21.5	2.0	5	9.0	19.5	11.5	8.5	12.5	8.5	9.5	7.5	1.5	5.0	21.5	7.5
24	24	35	33	39	3	32.0	38.0	23.5	2.0	5	9.0	19.5	11.5	8.5	12.5	8.5	9.5	7.5	1.5	5.0	23.0	7.5
25	25	36	34	40	3	32.0	38.0	26.5	2.0	5	9.0	19.5	11.5	8.5	12.5	8.5	9.5	7.5	1.5	5.0	24.5	7.5
26	26	37	--	--	--	34.0	40.0	--	--	--	9.0	--	--	--	13.0	9.0	10.0	8.0	1.5	5.0	24.5	--
28	28	40	37	43	3	36.0	42.0	26.5	2.0	5	9.0	19.5	11.5	8.5	14.0	10.0	11.0	9.0	1.5	5.0	24.5	7.5
30	30	43	39	45	3	39.2	45.0	26.5	2.0	5	9.0	19.5	11.5	8.5	14.0	11.5	11.0	10.5	1.5	5.0	24.5	7.5
32	32	46	42	48	3	42.2	48.0	28.5	2.0	5	9.0	19.5	11.5	8.5	14.0	11.5	11.0	10.5	1.5	5.0	28.0	7.5
33	33	47	42	48	3	--	--	28.5	2.0	5	9.0	19.5	11.5	8.5	--	12.0	--	--	--	--	--	7.5
35	35	49	44	50	3	46.2	52.0	28.5	2.0	5	9.0	19.5	11.5	8.5	14.5	12.0	11.5	11.0	1.5	5.0	28.0	7.5
38	38	53	49	56	4	49.2	55.0	33.5	2.0	6	9.0	22.0	14.0	10.0	14.5	11.3	11.5	10.3	1.5	5.0	31.0	9.0
40	40	56	51	58	4	52.2	58.0	36.0	2.0	6	9.0	22.0	14.0	10.0	14.5	11.8	11.5	10.8	1.5	5.0	34.0	9.0
42	42	59	--	--	--	53.3	62.0	--	--	--	9.0	--	--	--	17.0	13.2	14.3	12.0	2.0	6.0	35.0	--
43	43	59	54	61	4	--	--	38.5	2.0	6	9.0	22.0	14.0	10.0	--	13.2	--	--	2.0	--	--	9.0
45	45	61	56	63	4	55.3	64.0	39.5	2.0	6	9.0	22.0	14.0	10.0	17.0	12.8	14.3	11.6	2.0	6.0	36.5	9.0
48	48	64	59	66	4	59.7	68.4	46.0	2.0	6	9.0	22.0	14.0	10.0	17.0	12.8	14.3	11.6	2.0	6.0	42.0	9.0
50	50	66	62	70	4	60.8	69.3	45.0	2.5	6	9.0	23.0	15.0	10.5	17.0	12.8	14.3	11.6	2.0	6.0	43.0	9.5
53	53	69	65	73	4	--	--	47.0	2.5	6	9.0	23.0	15.0	12.0	--	13.5	--	--	--	--	--	11.0
55	55	71	67	75	4	66.5	75.4	49.0	2.5	6	9.0	23.0	15.0	12.0	18.0	14.5	15.3	13.3	2.0	6.0	47.0	11.0
58	58	76	70	78	4	69.5	78.4	55.0	2.5	6	9.0	23.0	15.0	12.0	18.0	14.5	15.3	13.3	2.0	6.0	50.0	11.0
60	60	78	72	80	4	71.5	80.4	55.0	2.5	6	9.0	23.0	15.0	12.0	18.0	14.5	15.3	13.3	2.0	6.0	51.0	11.0
63	63	83	75	83	4	--	--	55.0	2.5	6	9.0	23.0	15.0	12.0	--	14.2	--	--	--	--	--	11.0
65	65	84	77	85	4	76.5	85.4	55.0	2.5	6	9.0	23.0	15.0	12.0	18.0	14.2	15.3	13.0	2.0	6.0	52.0	11.0
68	68	88	81	90	4	82.7	91.5	55.0	2.5	7	9.0	26.0	18.0	12.5	19.0	14.9	16.0	13.7	2.0	6.0	53.0	11.3
70	70	90	83	92	4	83.0	92.0	57.0	2.5	7	9.0	26.0	18.0	12.5	18.0	14.2	15.3	13.0	2.0	6.0	54.0	11.3
75	75	98	88	97	4	90.2	99.0	62.0	2.5	7	9.0	26.0	18.0	12.5	18.0	15.2	15.3	14.0	2.0	6.0	55.0	11.3
80	80	100	95	105	4	95.2	104.0	61.8	3.0	7	9.0	26.2	18.2	13.0	19.0	16.2	16.3	15.0	2.0	6.0	58.0	12.0

# LIDERING

## **LIDERING, S.A.**

Pg. Ferrocarrils Catalans, 106-108 · 08940 Cornellà de Llobregat BARCELONA

Service Ventes Nationales: 902 480 440

Service Ventes Internationales: +34 93 480 44 22

Fax 93 480 44 04



Pollensa, 2, Ofic. 8. Edif. Artemisa - Tartessos

28290 Las Rozas MADRID

Tel. 902 480 440 · Fax 91 361 40 20

## **LIDERING S.A.R.L.**

Parc des Aqueducs · Chemin du Favier RD 42 · 69230 Saint-Genis-Laval FRANCE

Tél. 04 72 67 02 67 - Fax 04 78 56 04 08

## **S.A. LIDERING N.V.**

BP 10 · 1410 Waterloo BELGIQUE-BELGIË

Tél. 00 34 93 480 44 22 - Fax 00 34 93 480 44 04

<http://www.lidering.com>

email: [info@lidering.com](mailto:info@lidering.com)