

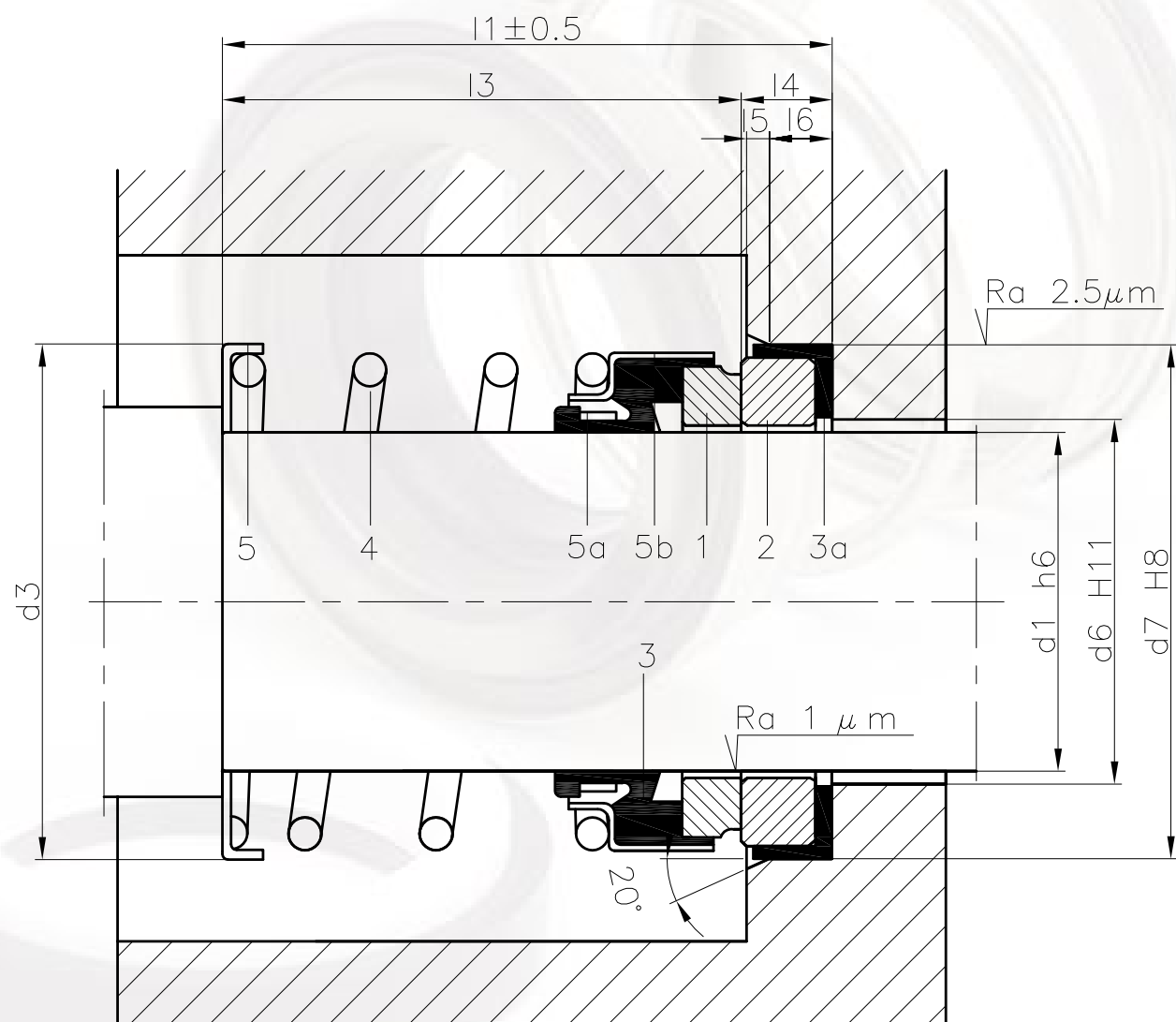

LIDE RING

GARNITURES MECÁNIQUES PNL



Garnitures Mécaniques PNL

Garniture mécanique à soufflet, non équilibrée, ressort simple, sens de rotation indépendant.



TABLEAU DIMENSIONNEL (Dimensions en mm. sujettes à variations ou modifications)

Ref.	d ₁	d ₃	d ₆	d ₇	l ₁	l ₃	l ₄	l ₅	l ₆
008	8.00	22	14	26.00	21.0	15.5	5.5	0.5	4.5
010	10.00	22	14	26.00	21.0	15.5	5.5	0.5	4.5
011	11.00	22	14	26.00	21.0	15.5	5.5	0.5	4.5
012	12.00	22	14	26.00	21.0	15.5	5.5	0.5	4.5
013	13.00	28	17	29.50	26.0	18.0	8.0	1.0	6.0
013	13.00	32	17	29.50	21.0	13.0	8.0	1.0	6.0
014	14.00	28	17	29.50	26.0	18.0	8.0	1.0	6.0
014	14.00	28	19	23.10	28.0	22.0	6.0	1.2	3.0
014	14.00	32	17	29.50	21.0	13.0	8.0	1.0	6.0
015	15.00	28	17	29.50	26.0	18.0	8.0	1.0	6.0
015	15.00	32	17	29.50	21.0	13.0	8.0	1.0	6.0
016	16.00	28	17	29.50	26.0	18.0	8.0	1.0	6.0
016	16.00	28	21	26.90	30.0	23.0	7.0	1.5	4.0
016	16.00	31	17	29.50	37.0	29.0	8.0	1.0	6.0
016	16.00	32	17	29.50	21.0	13.0	8.0	1.0	6.0
016	16.00	32	17	42.00	21.0	13.0	8.0	1.0	6.0
016	16.00	33	17	29.50	24.0	16.3	8.0	1.0	6.0
018	18.00	32	20	42.00	32.0	24.0	8.0	1.0	6.0
018	18.00	32	25	30.90	32.0	24.0	8.0	1.5	4.0
019.05	19.05	32	22	35.00	24.0	19.0	10.2	1.2	7.8
019.05	19.05	32	22	35.00	32.2	22.0	10.2	1.2	7.8
020	20.00	32	22	42.00	30.0	22.0	8.0	1.0	6.0
020	20.00	44	22	42.00	22.0	14.0	8.0	1.0	6.0
022	22.00	39	30	35.40	33.0	25.0	8.0	2.0	4.0
022	22.00	44	23	42.00	22.0	14.0	8.0	1.0	6.0
025.4	25.40	42	29	41.25	38.2	27.2	11.0	1.5	8.5
030	30.00	52	33	52.00	40.0	28.0	12.0	1.5	8.5
030	30.00	60	33	52.00	34.0	22.0	12.0	1.5	8.5
031.75	31.75	52	34	47.62	60.2	49.2	11.0	1.5	8.5
040	40.00	63	45	68.00	47.0	35.0	12.0	1.5	8.5

LIMITES D'UTILISATION

d₁ = 8 ÷ 40 mm

p = 12 Kg/cm²

v = 10 m/s

t = -20 ÷ +120°C

Les limites d'utilisation ci-dessus peuvent varier en fonction du facteur PV

MATERIAUX

BXPFF

BVPFF

CONSTRUCTION

1 Grain Mobile

2 Grain Stationnaire

3 Soufflet

3a Joints Secondaires en élastomère

4 Ressort

5 Anneau

5a Anneau de Blocage

5b Corps

Il existe d'autres combinaisons de matériaux

LIDERING

LIDERING, S.A.

Pg. Ferrocarrils Catalans, 106-108 · 08940 Cornellà de Llobregat BARCELONA

Service Ventes Nationales: 902 480 440

Service Ventes Internationales: +34 93 480 44 22

Fax 93 480 44 04



Pollensa, 2, Ofic. 8. Edif. Artemisa - Tartessos

28290 Las Rozas MADRID

Tel. 902 480 440 · Fax 91 361 40 20

LIDERING S.A.R.L.

Parc des Aqueducs · Chemin du Favier RD 42 · 69230 Saint-Genis-Laval FRANCE

Tél. 04 72 67 02 67 - Fax 04 78 56 04 08

S.A. LIDERING N.V.

BP 10 · 1410 Waterloo BELGIQUE-BELGIË

Tél. 00 34 93 480 44 22 - Fax 00 34 93 480 44 04

<http://www.lidering.com>

email: info@lidering.com