

PB-1 - adjustable from 42 to 60mm

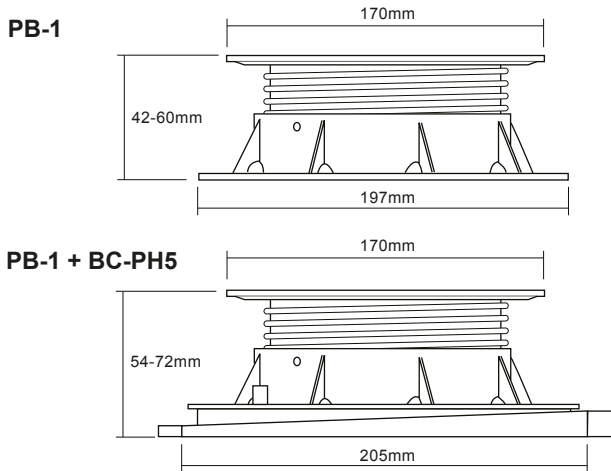

Adjustable height

Adjustable height from 42 to 60mm uninterrupted.
With addition of a 0 to 5% BC-PH5 slope corrector, adjustable from 54 to 72mm.

Composition

The PB-1 is composed by 2 pieces (head + base).

Material

Copolymer polypropylene (CPP), material thickness 3 to 4.5mm
Composition: 80% recycled PPC, 20% talc + UV black masterbatch and 100% recyclable.

Dimensions of the PB-1 pedestal

Head = diameter 170mm – Installation surface 227cm²
Base = diameter 197mm – Ground surface 305cm²

Performances

Resisting UV light, weather, sea salt and almost all chemicals
Temperature range: -30° to + 90°

Applications

Support for outdoor terraces with any kind of materials: timber decking, stone, ceramic, composite materials, metal, fiberglass grid... Can be placed on any stable substrate, also over insulation panels.

Slope corrector BC-PH-5 from 0 to 5%

Slope corrector BC-PH5 is placed under the base of pedestal PB-1. Consisting of 2 cylindrical parts, it allows to compensate for 1 to 5% slopes by simply rotating the devices.

Thickness of BC-PH-5 = + 12 mm to be added to the adjustable height of pedestal PB-1.



Accessories

Different BUZON accessories can be clipped to the head of pedestal PB-1 according to the materials used by manufacturers of terraces, podiums and temporary exhibitions (pedestals, gratings, tiles, etc.) and other parts for specific applications demanded by manufacturers.

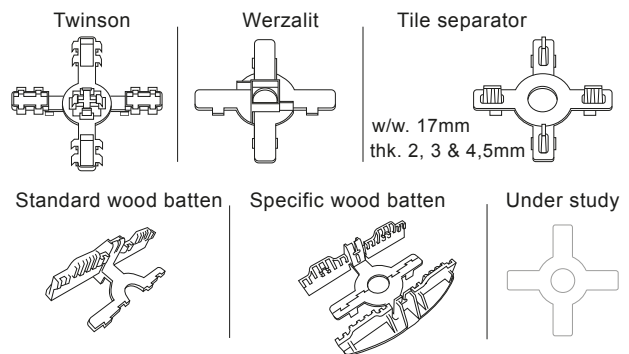

Compression test (1daN = 1Kg/f = 2,23lbf)

Performed on the full (1/1), half (1/2) or quarter (1/4) surface of the head.

Position	Height(mm)	Breaking Load(daN)	Breaking Load(lbf)
1/1	60	1435	3200
1/2	60	793	1769
1/4	60	553	1232

Safety recommendation for use of Buzon Pedestals System :

1. Areas reserved for **pedestrian access** : divide the load indicated in the table by 2 with an addition safety factor of -15%.
2. Areas reserved for **industrial and technical applications** : divide the load indicated in the table by 4 with an addition safety factor of -15%.
3. The BUZON Pedestals System is **not designed to support or be subjected to vibrating** and/or moving machinery & equipment, including maintenance & cleaning vehicles, automobile & other vehicles, etc...



Buzon Pedestal International s.a./ n.v.

Z.I. des Hauts-Sarts, Zone 1 - Prolongement de la rue de l'Abbaye, 134 - B-4040 Herstal - Belgium

Tel +32 (0)4 248 39 83

Fax +32 (0)4 264 82 38

E-Mail info@buzon.eu

www.buzon.eu