



Eco-Friendly & Be Bright

Pendant Light









PL-009-00A / PL-015-00B

Energy saving 80%
Compared to incandescents lamp

It's a new developing pendant light integrated the forefront LED technology and solid-state design. With features of low energy consumption and efficient heat dissipation. The elegant appearance and warm light will make you more comfortable and enjoyable!

Feature

LED Light

-  ● Environmentally friendly.
-  ● Decrease energy consumption.
-  ● No UV, IR, mercury and other harmful materials.
-  ● Long lifespan 50,000hours.
-  ● Easy to install and maintenance free.
-  ● No flickering & FR interference.
-  ● Reduces Light Pollution, enhances Night Vision
-  ● High Shock / Vibration Resistance



Application

LED Light

Best choice for indoor household & commercial down light, such as Bar Counter, Dining Room, Coffe house, restaurant, Excellent design for Ceiling installation.



Specification

LED Light

Model	PD-009-00A	PD-015-00B
Power Consumption(W)	9W	15W
Color Temp (K)	2800K-3200K 6000K-6500K	2800K-3200K 6000K-6500K
Luminous Flux(lm)	780lm	1300lm
Luminous Efficacy(lm/W)	80	80
Color Rendering(Ra)	> 80	> 80
Lifespan(h)	50,000	50,000
Input Voltage(V)	AC 100-265V	AC 100-265V
Operation Temp(°C)	-20 ~ 40	-20 ~ 40
Dimension(mm)	Φ240*730H±1mm(Customized available)	Φ240*730H±1mm(Customized available)
Body Material	AL/Glass	AL/Glass
Lighting Angel	>120°	>120°

Dimension(mm)

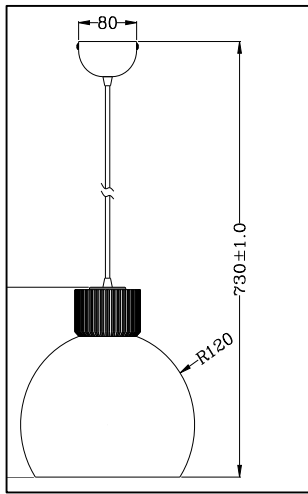

Illuminance(Lx)

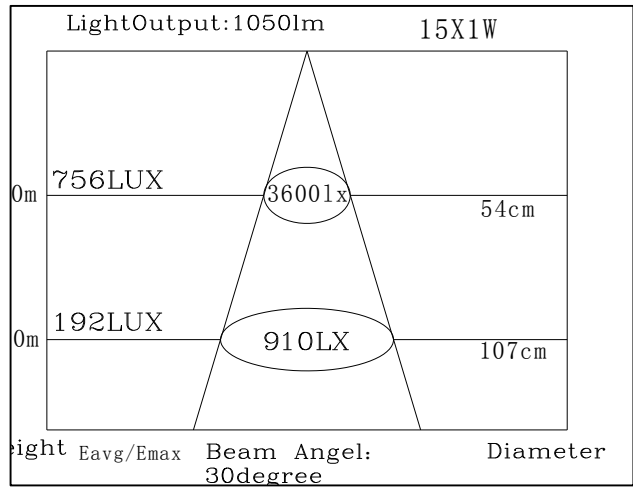

Beam Angel & CCT

LED Light

