

**FISA TEHNICA FT-3-04**

**BANDA TRANSPORTOARE CU RACLETI TIP "CHEVRON"; BTRC - 2**

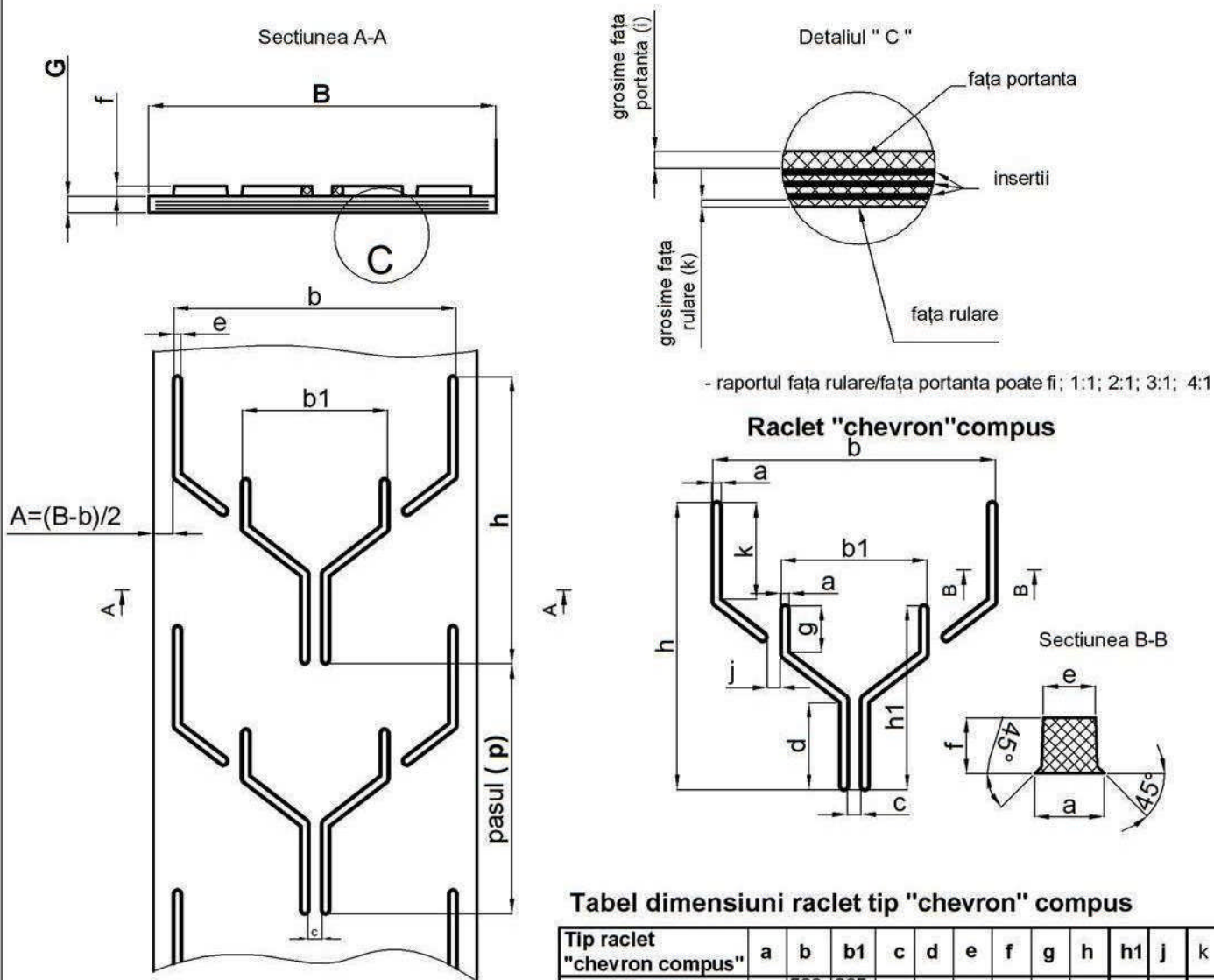

**Tabel dimensiuni raclet tip "chevron" compus**

Tip raclet "chevron compus"	a	b	b1	c	d	e	f	g	h	h1	j	k
CC - 520		520	265									
CS - 620	20	620	315	30	190	15	16	100	620	400	35	210
CS - 820		820	415									

**Tabel dimensiuni banda cu racleti "chevron" compusi; BTRC-2**

Tip banda cu raclet Latime banda	Tip raclet "chevron" compus pretabil la tipul de banda	p pas racleti	G
BTRC - 2 - 600	CC-520	minim 540 mm sau dupa cerinta beneficiarului	grosimea benzii 3.....14 mm, in functie de cerinta beneficiarului
BTRC - 2 - 650	CS-520;		
BTRC - 2 - 700	CC-520; CC-620		
BTRC - 2 - 750	CC-520; CC-620		
BTRC - 2 - 800	CC-520; CC-620		
BTRC - 2 - 1000	CC-520; CC-620; CC820		

**NOTA:**

Se pot executa benzi cu racleti chevron de latimi intermediare celor indicate in tabel .  
Racletii tip " chevron " compusi pot fi dispusi pe banda si dupa specificatia clientului.  
Toate cotele sunt exprimate in milimetri