



SERIE AD ASTA DI SPINTA STRAIGHT-LINE ACTION SERIES

In questa serie, il movimento circolare della leva di comando si trasforma in movimento lineare dell'asta di spinta. Eccezion fatta per i due modelli 120/AS e 300/AS, questa serie lavora e blocca sia a spinta che a trazione. La versione leggera copre esigenze di bloccaggio da 80 a 720 daN, mentre la serie pesante copre esigenze da 120 a 4500 daN.

ESECUZIONE

PER LA SERIE LEGGERA: Parti in lamiera d'acciaio da cementazione uni 5867. Asta di spinta in acciaio UNI 7230-73 con boccia di guida in ottone.

La caratteristica principale dei modelli ASD/ASS è il basso punto d'applicazione della forza nonché l'ingombro in senso verticale molto contenuto. Per i modelli 80-165-340/AS vi è possibilità di montaggio frontale con un filetto esterno che permette la rotazione della leva di comando nella posizione più favorevole all'uso. La squadretta di fissaggio sul piano aumenta le possibilità d'impiego.

PER LA SERIE PESANTE: Corpo base in ottone verniciato nero per le grandezze 70 e 160. Corpo base in acciaio forgiato UNI 7063 verniciato nero per le altre grandezze. Parti in lamiera di acciaio da cementazione UNI 5867 zincate. Aste di spinta in acciaio UNI 7230-73 zincate. Perni e boccole di supporto induriti per cementazione.

In these devices the circular movement of the handles is transformed in a straight-line action of the clamp along its axis. Excepted for Mod.120/AS and 300/AS, these tools can work and clamp either pushing and pulling. The light series meets clamping requirements from 80 to 720 daN, while the heavy series from 120 to 4500 daN.

SPECIFICATIONS

LIGHT SERIES: Components in UNI 5867 case-hardening sheet steel. UNI 7230-73 steel plunger and brass supporting bushes. The main feature of models ASS/ASD is the low application point and the very reduced vertical encumbrance. For models 80-165-340/AS the frontal fixing is allowed by an outer worm giving the control lever the possibility to swivel into any position, and meet the space requirements. The bracket increase the range of applications.

HEAVY SERIES: Main unit in chemi black brass for sizes 70 and 160. Main unit in forged steel chemi black UNI 7063 for other sizes. Components in galvanized UNI 7230-73 case hardening sheet steel. Galvanized UNI 5867 steel plungers. Pivots and bushes hardened.

SERIE AD ASTA DI SPINTA STRAIGHT-LINE ACTION SERIES

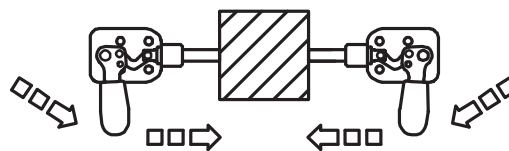

Tipo ASD - serraggio a pressione con rotazione a destra.
 Tipo ASS - serraggio a pressione con rotazione a sinistra.

Model ASD - right rotation clamp.
 Model ASS - left rotation clamp.

FORMA
ASS
 FORM

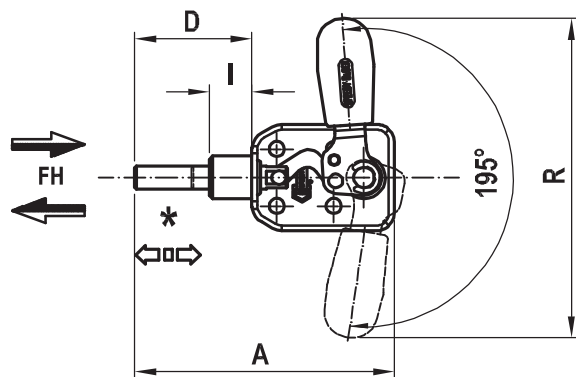
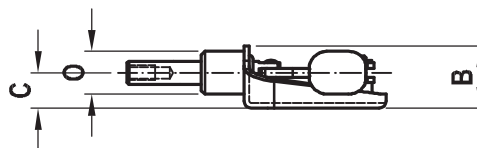

FORMA
ASD
 FORM

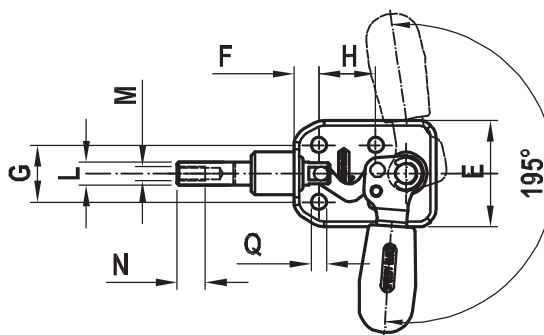

	A	B	C	D	E	F	G	H	I	L	M	N	O	Q	R	*	Fh (daN)	gr.
50/ASD	73	17,5	10	33	30,5	7	16	16	12	6,5	M4	9	12	4,3	90	16	80	60
50/ASS	73	17,5	10	33	30,5	7	16	16	12	6,5	M4	9	12	4,3	90	16	80	60

SERIE AD ASTA DI SPINTA STRAIGHT-LINE ACTION SERIES

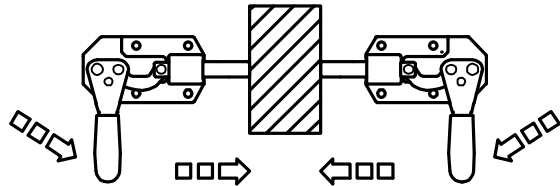

Tipo ASD - serraggio a pressione con rotazione a destra.
 Tipo ASS - serraggio a pressione con rotazione a sinistra.

Model ASD - right rotation clamp.
 Model ASS - left rotation clamp.

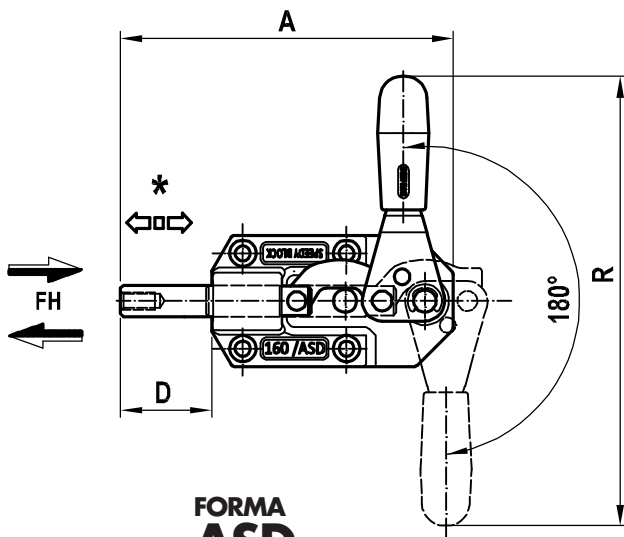

**FORMA
ASD
FORM**

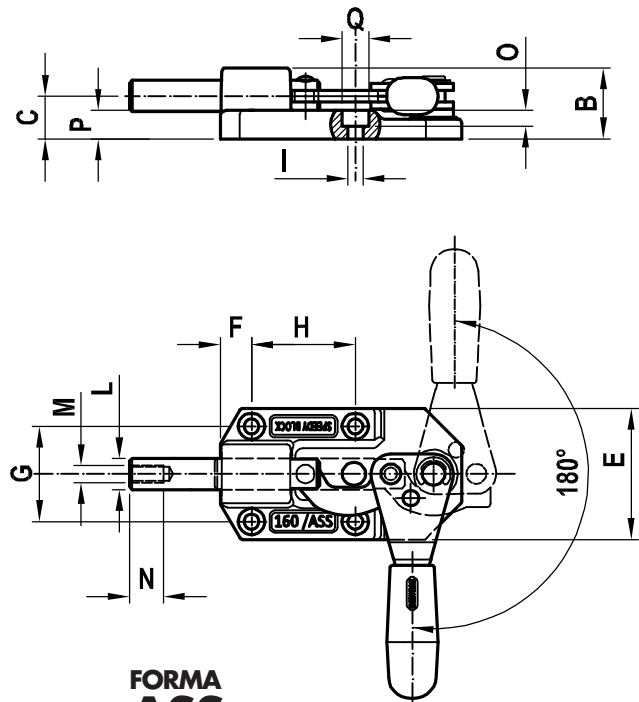

**FORMA
ASS
FORM**

	A	B	C	D	E	F	G	H	I	L	M	N	O	P	Q	R	*	Fh (daN)	gr.
70/ASD	85	19,5	12	22	36	13	26	26	4,3	8,5	M6	12	4,2	6	7,3	98	20	90	170
70/ASS	85	19,5	12	22	36	13	26	26	4,3	8,5	M6	12	4,2	6	7,3	98	20	90	170
160/ASD	117	25	15	32	46	11,5	33,5	36,5	5,3	11	M6	12	5,5	10	9,3	158	30	130	400
160/ASS	117	25	15	32	46	11,5	33,5	36,5	5,3	11	M6	12	5,5	10	9,3	158	30	130	400

SERIE AD ASTA DI SPINTA STRAIGHT-LINE ACTION SERIES

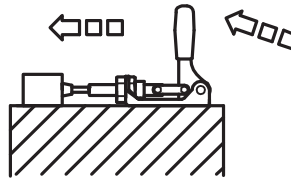

Questa serie lavora solo a spinta.

For push action only.

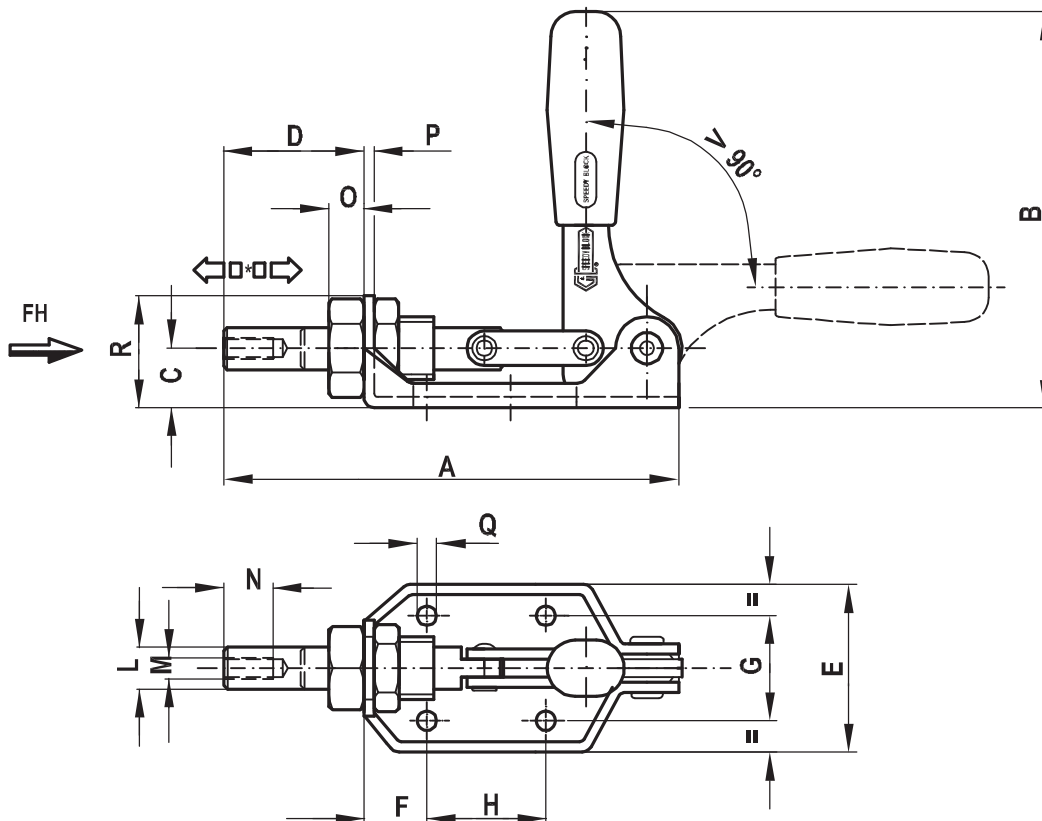

	A	B	C	D	E	F	G	H	L	M	N	O	P	Q	R	*	Fh (daN)	gr.
120/AS	130	111	17	40	48	18	30	34	12	M6	12	10	3	5,5	32	20	360	350
300/AS	167	140	20	57	58	18	34	50	14	M8	16	12	3	6,5	36	33	720	560

SERIE AD ASTA DI SPINTA STRAIGHT-LINE ACTION SERIES

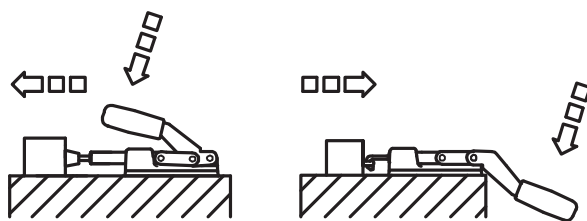

Questa serie azionata pneumaticamente si trova a pag. 62.

You can find this series in power version at page 62.

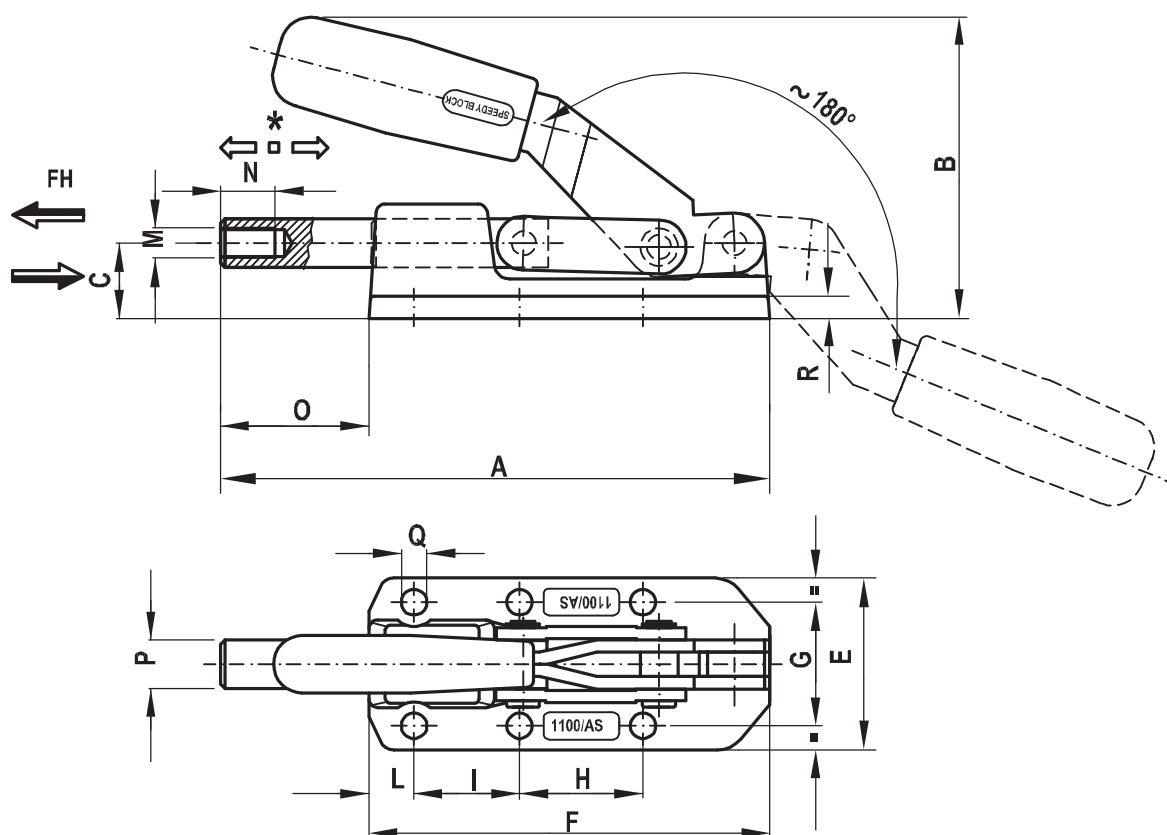

	A	B	C	E	F	G	H	I	L	M	N	O	P	Q	R	*	Fh (daN)	gr.
70/AS	86	42,5	12	36	64	26	26		13	M6	12	22	8,5	4,3	6	20	120	170
160/AS	116	56	15	46	85	33,5	36,5		11	M6	12	31	11	5,5	10	30	280	400
360/AS	122	72	25	45,5	90	33,5	36,5		30	M8	15	32	12	5,5	7	32	560	440
550/AS	164,5	76	18	55	122,5	41	41	35	15	M8	16	42	14	7	6	42	800	700
1100/AS	182	95	25	57	133	41	41	35	15	M10	18	49	16	8,5	8	50	1600	1060
2100/AS	238	118,5	35	70	177	50	50	50	35	M12	22	61	20	8,5	10	60	2500	2280
3100/AS	316	137	40	76	216	54	70	70	40	M14	25	100	22	11	10	100	4500	3350

SERIE AD ASTA DI SPINTA STRAIGHT-LINE ACTION SERIES

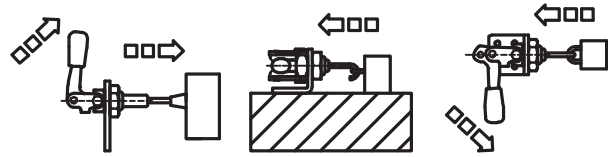

La squadretta di fissaggio sul piano non è compresa nella fornitura.

ANCHE IN ACCIAIO INOX (Vedi tabella)

The bracket is not supplied with standard package.

IN STAINLESS STEEL AS WELL (See below)

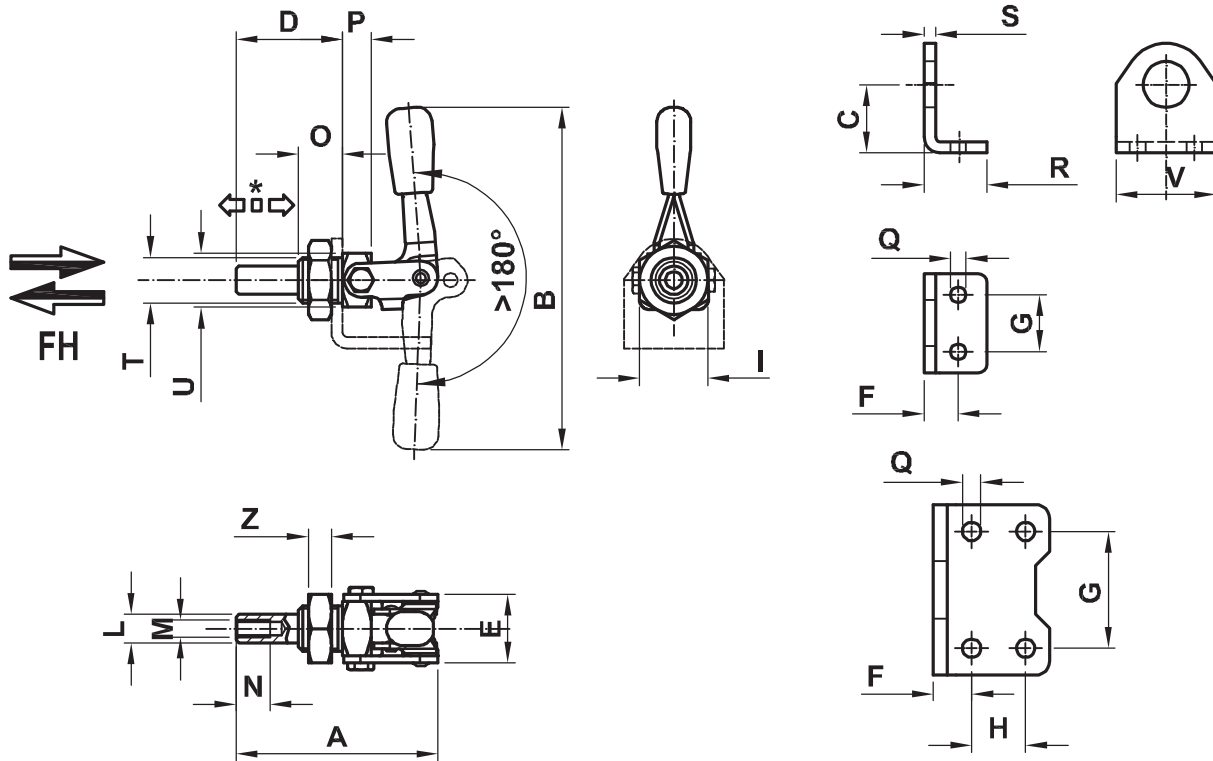

	INOX	A	B	D	E	I	L	M	N	O	P	T	U	Z	*	Fh (daN)	gr.
80/AS	80/ASX	71	120	38	24	24	10	M6	12	15,5	10	M16X1,5	19	8	21	300	135
165/AS	165/ASX	113	194	59	28	30	12	M8	15	20	16	M20X1,5	22	9	38	540	335
340/AS	340/ASX	173	256	90	38	36	16	M10	18	22	28	M24X2	30	10	66	700	835

	INOX	C	F	G	H	Q	R	S	V	Supporto per modello Bracket for model
30080	30080X	24	12	20	-	5,5	22	4	35	80/AS - 80/ASX
30165	30165X	32	13,5	41	19	6,5	41	5	60	165/AS - 165/ASX
30340	30340X	48	19	55	25	8,5	59	5	75	340/AS - 340/ASX