

PRODUCENT PROFESJONALNYCH
URZĄDZEŃ CHŁODNICZYCH
PRODUCER OF PROFESSIONAL REFRIGERATION EQUIPMENT

JBG 2[®]

www.jbg.com.pl



LDE-xxx-05/06/07

Elegant

POLSKI • ENGLISH • DEUTSCH • FRANCAIS





LDE-xxx-05/ 06/ 07

PL

LDE-xxx-05/ 06/ 07

Wyposażenie standardowe:

- sterownik elektroniczny • automatyczne odparowanie skroplin • oświetlenie górne jednorzędowe • półki zawieszane, szklane z podświetleniem • barwa światła: cukiernicza • spodnia powierzchnia ekspozycyjna z płyty impregnowanej w kolorze TEAK 23-35 • stelaże półek w kolorze złotym • kolorystyka panelu przedniego: TEAK 23-35 • kolorystyka cokołu: czarny (RAL 9005) • szyba zespolona, gięta, hartowana z sitodrukiem w kolorze złotym • LDE-xxx-07 wersja samoobsługowa (niska szyba przednia) • drzwiczki tylne przesuwne, szyba zespolona

EN

LDE-xxx-05/ 06/ 07

Standard Outfit:

- electronic controller • automatic condensate evaporation • one-row top lighting • suspended glass shelves with lightning • confectionery tone of light • lower display surface made of impregnated plate, colour TEAK 23-35 • gold colour shelves superstructures • colour of front panel: TEAK 23-35 • colour of base: black (RAL 9005) • thermopane glass: bent, hardened, silk-screen painted in gold • LDE-xxx-07 self-service version (low front glass) • sliding back door, thermopane glass

DE

LDE-xxx-05/ 06/ 07

Standardausrüstung:

- elektronischer Regler • automatische Tauwasserverdunstung • einreihige Oberbeleuchtung • aufgehängte Glaszwischenablage mit Beleuchtung • Lichtfarbe: Bäckerlicht • Boden-Ausstellungsfläche aus imprägnierter Sperrholzplatte, TEAK 23-35 • Glaszwischenablage auf goldenem Aufbau • Farbe des Frontpaneels: TEAK 23-35 • Sockelfarbe: schwarz RAL9005 • komplexe Scheibe, gebogen, gehärtet, mit goldenem Siebdruck • LDE-xxx-07 - Selbstbedienung (niedrige Frontscheibe) • Rückseite: schiebbare Tür aus komplexem Glas

FR

LDE-xxx-05/ 06/ 07

Equipement standard

- Contrôleur électronique • Système d'évaporation automatique • Eclairage frontal simple • Etagères inclinables, vitrées, avec éclairage • Couleur de la lumière: pâtisserie • Surface d'exposition inférieure en plaque imprégnée en couleur TEAK 23-35 • Supports d'étagères en couleur dorés • Décor façade en couleur TEAK 23-35 • Soubassement noir RAL 9005 • Glace bombée rabattable en couleur dorés • LDE-xxx-07-version libre-service (glace basse bombée) • Portes arrière coulissantes, glace accouplée



opcje / akcesoria • option / accessories Option / Zubehör • option / accessoires	LDE -XXX- 05	LDE -XXX- 06	LDE -XXX- 07
• podłączenie na agregat zewnętrzny • connection to external cooling unit • Anschluß für externes Aggregat • connexion au groupe externe	✓	✓	✓
• podświetlanie cokołu • lighting of the base • Sockelbeleuchtung • illumination du soubassement	✓	✓	✓
• oświetlenie LED • LED lighting • LED-Beleuchtung • Eclairage de consommation basse d'énergie LED	✓	✓	✓
• barwa światła • tone of light • Lichtfarbe • teinte de lumière	✓	✓	✓
• ozdobny reling ze stali nierdzewnej • decorative tube bumper from stainless steel • Reling – dekorativ, aus rostbeständigem Stahl • rail décoratif en acier inox	✓	✓	✓
• kółka • wheels • Räder • roulettes	✓	✓	✓
• kolor do wyboru z palety RAL • colour selection from the RAL palette • Farbe zur Auswahl gemäß RAL-Palette • couleur au choix du nuancier RAL	✓	✓	✓
• kolorystyka stelaży wg palety RAL • colour of shelves according to the RAL palette • Gestellfarben gemäß RAL-Palette • couleurs des cadres selon le nuancier RAL	✓	✓	✓
• kolorystyka obudowy wg wzornika TEAK • colour of casing according to the pattern book TEAK • Gehäusefarben gemäß dem Musterbuch von TEAK • couleurs de selon le nuancier TEAK	✓	✓	✓
• kolorystyka cokołu wg palety RAL • colour of base according to the palette RAL • Sockelfarben gemäß der RAL-Palette • couleurs de soubassement selon le nuancier RAL	✓	✓	✓
• Szyby z sitodrukiem w kolorze srebrnym • glass with silk –screen panted in Silver • Scheiben mit silberem Siebdruck • Glace avec decoration argent	✓	✓	✓
• powierzchnia ekspozycyjna / wnętrze z blachy nierdzewnej • stainless steel exposition surface/ interior • Ausstellungsfläche / Innenverkleidung aus Edelstahl • Surface d'exposition / partie interne en tôles Inox	✓	✓	✓
• układ stabilizacji wilgotności • humidity controller • Luftfeuchteregelung • contrôle d'humidité	✓	✓	✗

Legenda, Legend, Legende, Clé:

- S** występuje w standardzie • standard • im Standard enthalten • existe en standard
✓ opcja dostępna • option available • erhältliche Option • option disponible
✗ opcja niedostępna • option non available • nicht erhältliche Option • option pas disponible



TEAK 23-35 *

KOLOR EKSPOZYCJI I PANELA PRZEDNIEGO
 COLOUR OF EXPOSITION AND FRONT PANEL
 FARBE DES FRONTPANEELS UND DER AUSSTELLUNGSFLÄCHE
 COULEUR D'EXPOSITION ET DECOR FRONTAL

- * Odcień koloru może różnić się od oryginału
 * Shade may slightly differ from the original
 * Der Farbton kann vom Original geringfügig abweichen
 * La nuance de la couleur peut être légèrement différente de l'original





LDE-xxx-05/ 06/ 07

Symbol / Symbol Symbol / Symbole	LDE			LOE		
Model / Type Modell / Type	05	06	07	05	06	07
Urządzenie Equipment Ausrüstung Equipement	chłodnicze dynamiczne; agregat wewnętrzny dynamic refrigeration; internal unit dynamisch Kühlung; internes Aggregat froid ventilé; groupe loge			niechłodnicze non-cooling ohne Kühlung sans froid		
Klasa temperaturowa Temperature class Temperaturklasse Classe de temp.	3H1 (+2°C - +8°C)		3H1 (+4°C - +8°C)			
Wysokość / Height Höhe / Hauteur	1355	1135	1355	1355	1135	1355
Szerokość / Width Breite / Profondeur	750			750		
Moduł / Module Modul / Module	długość (mm) / length (mm) / Länge (mm) / longueur (mm)					
0,9	940	940	×	940	940	×
1,4	1440	1440	1440	1440	1440	1440
NZ45	×	×	×	965	965	×
NW45	×	×	×	390	390	×



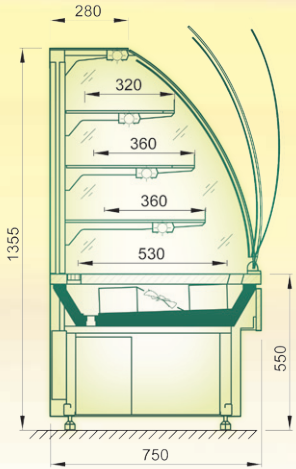

LDE-xxx-05

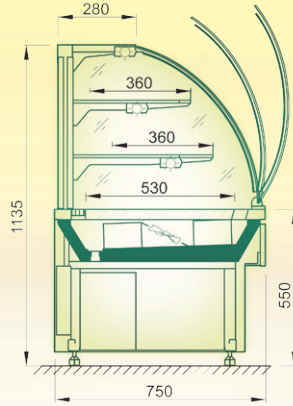

LDE-xxx-06

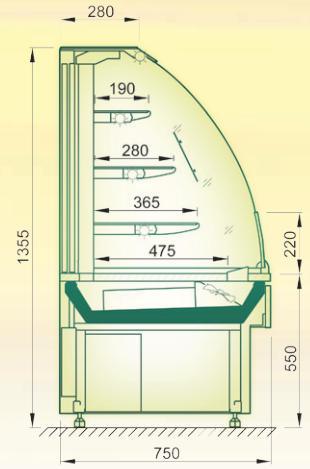

LDE-xxx-07



LDE-xxx-05



LOE-NZ45-05



LBE-BK-05/06

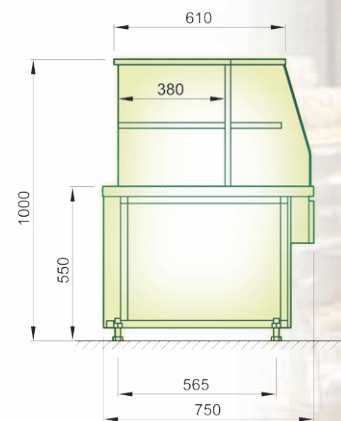

LBE-BK-05/06

LDE-xxx-05



LDE-xxx-05/ 06/ 07

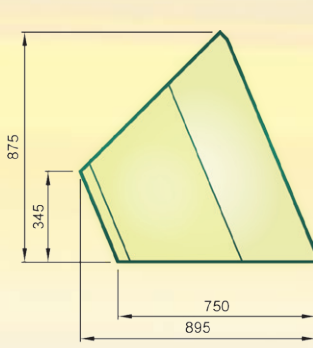

LOE-NW45-05/06

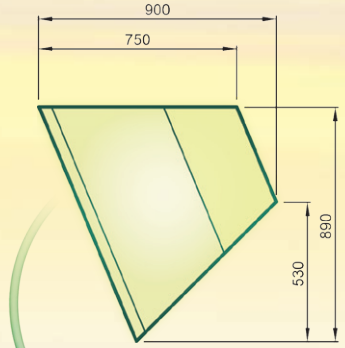

LOE-NZ45-05/06

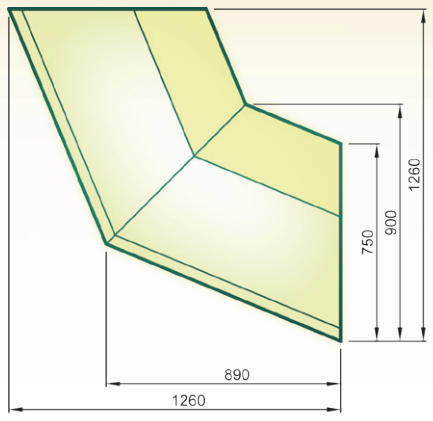

LOE-NZ90-05/06

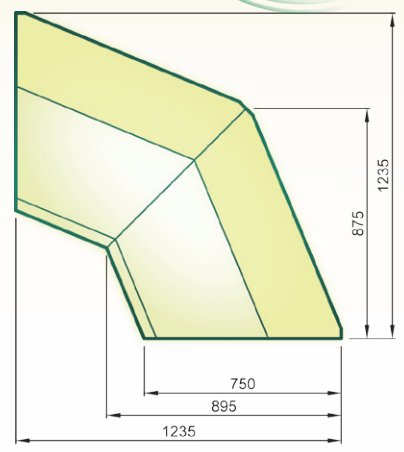

LOE-NW90-05/06



for confectionery
Nefryt SDN-06-G1

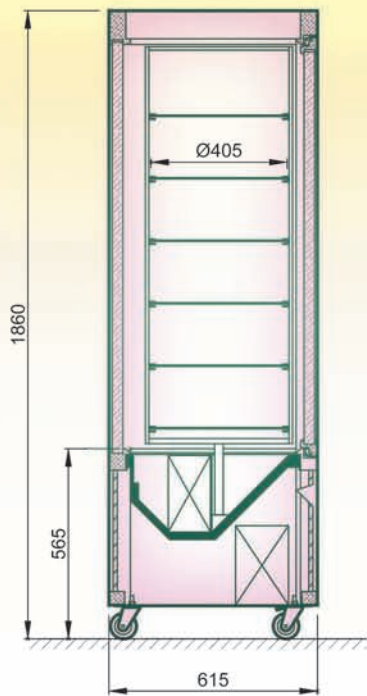

SDN-06-G1



SDN-06-G1



LDE-xxx-05



JBG-2 Sp. z o.o.
43-254 Warszowice ul. Gajowa 5
www.jbg.com.pl

DZIAŁ HANDLOWY

tel. +48 32 475 91 35
tel. +48 32 475 91 37
tel. +48 32 475 91 39
fax +48 32 475 91 36
handlowy@jbg.com.pl

EXPORT DEPARTMENT

tel. +48 32 475 91 52
tel. +48 32 475 91 53
tel. +48 32 475 91 54
fax +48 32 475 91 36
export@jbg.com.pl

! Producent zastrzega sobie prawo zmiany charakterystyki urządzenia
The manufacturer reserves the right to alter the features and technical specifications of its products
Der Hersteller behält sich das Recht vor, die Charakteristik und die technischen Parameter der Kühlmöbel zu ändern
Le fabricant réserve le droit de changer les caractéristiques et les spécifications techniques de ses produits