

Type RC3 Load Cell



Flintec load cells are designed to meet the most stringent accuracy requirements. Certifications have been obtained from Weights & Measures Authorities, worldwide.

RC3 rocker column load cells are available in the capacities 7.5 t to 300 t and include Accuracy Classifications GP, C1, C3, C4, and C3 MI 8 according to OIML R 60; NTEP $n_{max} = 10000$.

They offer total stainless steel construction and complete hermetic sealing, making them suitable for use in the toughest industrial environments.

This load cell design, in combination with a low cost self aligning rocker assembly, unites excellent load introduction with a low profile outline.

The Flintec calibration technique (in $mV/V/\Omega$) eliminates time consuming corner calibration in multiple load cell systems.

The RC3 is available for use in hazardous areas zone 0, 1, 2 (gas) and 20, 21, 22 (dust) according to EEx ia IIC T6...T4 T130°C ATEX.

Important Features

- Capacities: 7,5 t to 300 t.
- High accuracy.
- Total stainless steel construction.
- Complete hermetic sealing.
- Protection IP 68.
- High input resistance: 1100 Ω .
- W&M certified for 4000 intervals. (PTB: D09-99.09 Rev. 2)
- Calibration in $mV/V/\Omega$.
- Easy cable replacement.
- Complete range of loading hardware available.
- Factory Mutual approved.

Options

- Explosion protection zone 0, 1, 2 and 20, 21, 22 ATEX.
- Integrated surge arrestors (4x).

RC3 Specifications

Maximum capacity	(E _{max})	t	7.5 / 15 / 22.5 / 30 / 40 / 50 / 100 / 150 / 300	7.5 / 15 / 22.5 / 30 / 40 / 50		
Rated Output	(Cn)	mV/V	2 ± 0.1%			
Calibration in mV/V/Ω (A...I classified)	%Cn	≤ ± 0.05 (≤ ± 0.005)				
Accuracy class according to OIML R 60		(GP)	C1	C3	C4	C3 MI 8
Maximum number of verification intervals	(n _{max})	n.a.	1000	3000	4000	3000
Minimum load cell verification interval	(v _{min})	n.a.	E _{max} /5000	E _{max} /15000		
Combined error	%Cn	≤ ± 0.040	≤ ± 0.030	≤ ± 0.020	≤ ± 0.018	≤ ± 0.015
Creep error (30 minutes) / DR	%Cn	≤ ± 0.060	≤ ± 0.049	≤ ± 0.016	≤ ± 0.012	≤ ± 0.006
Temperature effect on minimum dead load output	%Cn/°C	≤ ± 0.0040	≤ ± 0.0028	≤ ± 0.0009	≤ ± 0.0009	≤ ± 0.0009
Temperature effect on sensitivity	%/°C	≤ ± 0.0020	≤ ± 0.0015	≤ ± 0.0010	≤ ± 0.0008	≤ ± 0.0010
Excitation voltage	V	5...15				
Zero balance	%Cn	≤ ± 5				
Input resistance	Ω	1150 ± 50				
Output resistance	Ω	1000 ± 2				
Insulation resistance (100 DC)	MΩ	≥ 5000				
Compensated temperature range	°C	-10...+40				
Operating temperature range	°C	-40...+80				
Safe load limit	(E _{lim})	%E _{max}	200			
Ultimate load		%E _{max}	300			
Load cell material		stainless steel 17-4 PH (1.4548)				
Sealing		complete hermetic sealing; cable entry sealed by glass to metal header				
Protection according DIN 40.050		IP 68				

Dimensions

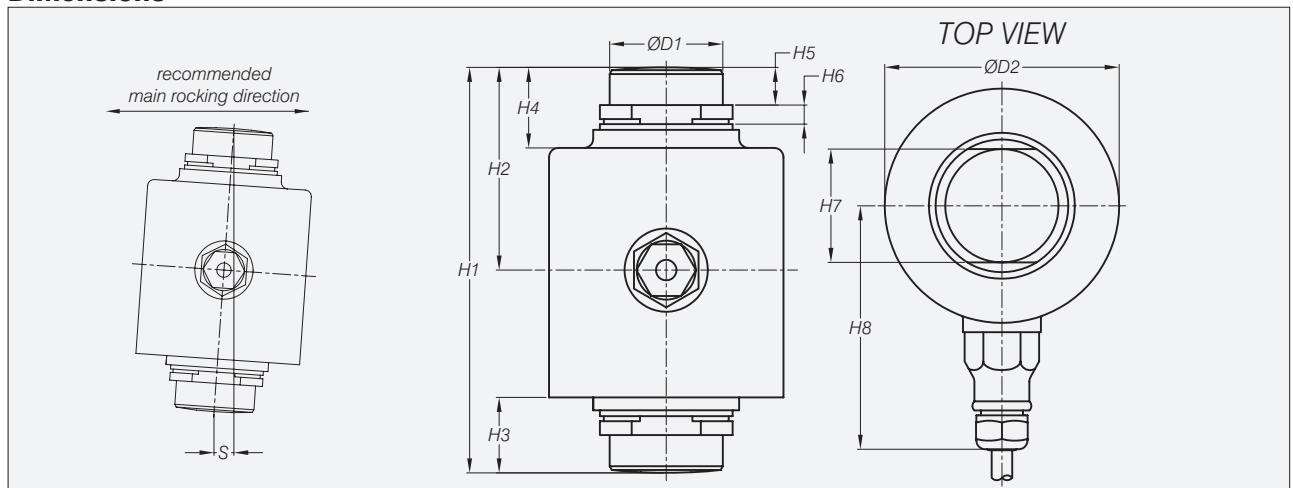

Type	H1	H2	H3	H4	H5	H6	H7	H8	D1	D2	S _{max} *	RF**
RC3-7.5 t	89	44	17	23	11	6	28	75	28	65	8	11 kN
RC3-15 t	89	44	17	23	11	6	28	75	28	65	7	20 kN
RC3-22.5 t	89	44	17	23	11	6	28	75	28	65	4.5	30 kN
RC3-30 t	140	70	26	28	13	6.5	39	84	39	81	10.5	34 kN
RC3-40 t	150	75	31	33	13	11.7	39	84	39	81	10	37 kN
RC3-50 t	178	89	32	34	17	8.5	44	94	44	99	9	51 kN
RC3-100 t	178	87	34.2	36	17	12	62	90	62	120	11.5	152 kN
RC3-150 t	210	101.4	40.4	38.6	20.6	12.8	76.2	109	76.2	160	14.5	240 kN
RC3-300 t	280	143.4	53.4	51.6	25	21.5	100	119	100	180	15	468 kN

* S_{max} = maximum lateral displacement of load introduction. Recommended gap 2...3 mm for 7.5...22.5 t, 3...5 mm for 30...300 t.
 ** RF = restoring force at S_{max} and E_{max}.

All dimensions in mm. Dimensions and specifications are subject to change without notice.

Wiring

- The load cell is provided with a shielded, 4 conductor cable (AWG 24 for 7.5 to 22.5 t / AWG 20 for 30 to 300 t). Cable jacket polyurethane.
- Cable length: 12 m for 7.5 to 22.5 t, 18 m for 30 to 300 t.
- Cable diameter: 5 mm for 7.5 to 22.5 t, 7.8 mm for 30 to 300 t.
- The shield is floating (On request the shield can be connected to the load cell body).

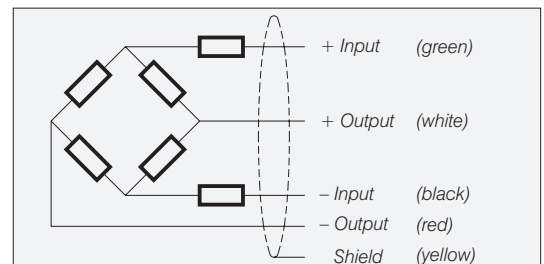

Compression Load Cells