

RAVAS-6100

Pallet truck scale with programmable scale functions

BENEFITS

- Advanced parts counting function
- Pivoting indicator
- Programmable scale functions
- RS232, RS485, 4-20 mA, 0-10V output
- For parts counting, data capture and special applications

Top quality

Customised functions



RAVAS

FUNCTIONS

- Automatic and manual zero correction
- Gross/net weighing
- Automatic and manual tare through numeric keypad
- Entry of alphanumeric codes (max. 10 characters) by keypad
- Internal memory for 9 pre-set tare values
- Totalling with sequence number
- Piece counting by sampling or calculation of piece weights
- Functions through parameters:
 - different print layout (on demand)
 - different basic functionality (e.g. dosing)
- Programmable functions:
 - customer specific software (on demand)
- Error messages in display
- Printer power supply is switched on and off by the indicator
- Internal clock
- Automatic switch off after 15 minutes of no activity

STANDARD SPECIFICATIONS

- Weighing capacity 2,200 kg
- Graduation multirange:
 - 0 - 200 kg: graduation 0.2 kg
 - 200 - 500 kg: graduation 0.5 kg
 - 500 - 2,200 kg: graduation 1 kg
- Max. tolerance 0.1% of the load lifted
- Display Pivoting LCD display, digit height 14 mm
- Foil keypad 20 keys
- Protection class load cells IP67, indicator IP65
- Power consumption 170 mA
- Battery 12V exchangeable battery module
- Battery life 8 hours, charging time 6 hours
- Charger 230V/12Vdc - 300 mA
- Steering wheels rubber
- Loading wheels polyurethane, single
- Colour red (RAL 3000), epoxy painted
- Own weight 110 kg
- Pump quick lift

DIMENSIONS IN MM

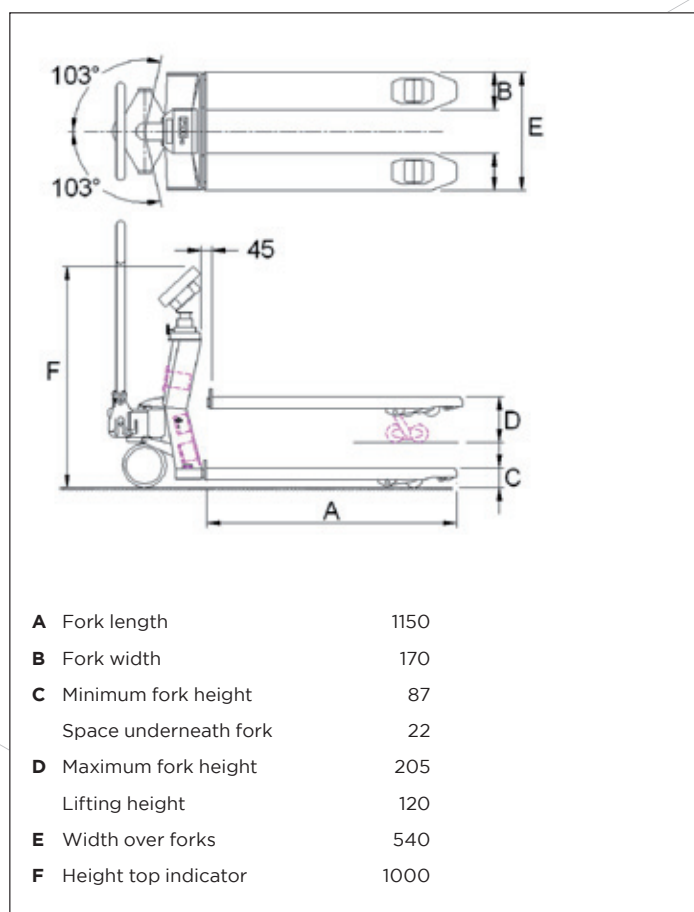

For approved versions, class OIML III: European approval no. T2782, switch-off of display when tilting more than 2°.

Graduation: multirange 0.2/0.5/1 kg, or one of the following fixed graduations:

- 1,000 divisions : 1.0/1,000 kg or 2.0/2,000 kg
- 2,000 divisions : 0.5/1,000 kg or 1.0/2,000 kg
- 3,000 divisions : 0.1/300 kg or 0.2/600 kg or 0.5/1,500 kg



PREMIUM OPTIONS*

- Built-in thermal printer
- Bluetooth or WLAN output
- Client specific software (6100s)
- Legal for trade version, OIML III

OPTIONS*

- Barcode reader/barcode printer (6100s)
- Extra exchangeable battery pack
- Multirange graduation 0.1/0.2/0.5 kg
- Stainless steel fork shoes
- Stainless steel or galvanized truck
- Footbrake or handbrake
- Different fork dimensions
- Different steering or loading wheels

* The use of options may change related specifications.

RAVAS Europe B.V.

P.O. Box 2023, NL-5300 CA Zaltbommel, The Netherlands
 T. +31 (0)418 51 52 20, F. +31 (0)418 51 53 20
 backoffice@ravas.com, www.ravas.com

RAVAS