

Tenazas ajustables para profesionales Professional locking pliers



Tornillo de acero templado para ajuste de apertura.
Tempered steel screw to adjust jaw opening

Tuerca de bloqueo
Locking nut

Manejo cómodo con cualquier espesor de piezas
Comfortable handling of any work piece thickness

Diseño ergonómico
Ergonomic design

Desbloqueo fácil y sin pellizcarse
Easy release with no pinching



Perfil cóncavo para empujar-estirar mejor
Concave profile for better push-pull working

Acero forjado tratado térmicamente.
Thermally treated forged steel



EpoxiPaint



Epoxi paint finishing

- 10 times more corrosion resistant than nickel.
- Far more environmentally friendly.
- Highly visible in the work place.

▶ 131 Grip Omnium / 131 Omnium grip

La más completa



COD	MOD			L		
53041	131-07*	0-5,2 cm.	4,4 cm.	20,2cm.	0,41	
53042	131-10*	0-6,7 cm.	5,6 cm.	25,4 cm.	0,71	
53043	131-12*	0-7 cm.	5,6 cm.	30,7 cm.	0,94	

Omnium grip

- Thermically treated forged steel jaws.
- Gives firm hold on all rounded and flat objects.

▶ 111 Grip bocas curvas / 111 Rounded grip pliers



COD	MOD			L		
53020	111-05*	0-3,2 cm.	2,2 cm.	14,3 cm.	0,21	
53021	111-07*	0-4,2 cm.	3,3 cm.	19,2 cm.	0,42	
53022	111-10*	0-6,2 cm.	4,1 cm.	23,8 cm.	0,65	
53023	111-12*	0-7,5 cm.	5,1 cm.	30,5 cm.	0,94	

Rounded grip pliers

- Thermically treated forged steel jaws.
- Gives a firm hold on all round shapes.

▶ 121 Grip bocas curvas con cortante / 121 Rounded grip pliers wire cutter



COD	MOD			L		
53030	121-05*	0-3,2 cm.	2,25 cm.	14,3 cm.	0,21	
53031	121-07*	0-4,2 cm.	3,3 cm.	19,2 cm.	0,42	
53032	121-10*	0-6,2 cm.	4,1 cm.	23,8 cm.	0,65	
53033	121-12*	0-7,5 cm.	5,1 cm.	30,5 cm.	0,94	

Curved jaws with wire cutter

- Tempered forged steel jaws Forged jaws.
- Gives firm hold on all round shapes.
- Cuts wire Ø1 to Ø4mm. with progressive bites.

▶ 112 Grip bocas rectas / 112 Straight jaws grip pliers



COD	MOD			L		
53050	112-05*	0-3,2 cm.	2,3 cm.	14,3 cm.	0,21	
53051	112-07*	0-4,2 cm.	3,3 cm.	19,2 cm.	0,44	
53052	112-10*	0-6,3 cm.	4,2 cm.	23,8 cm.	0,70	
53053	112-12*	0-7,5 cm.	5,8 cm.	30,5 cm.	1,00	

Rounded grip pliers

- Thermically treated forged steel jaws.
- Wide opening for greater work capacity.

▶ **727 Ergogrip / 727 ErgoGrip**

ErgoGrip

- Thermally treated forged steel.
- Increased Power for Push-Pull-Torque actions.
- Single handed use.



COD	MOD					
53001	727-08*	0-4,7 cm.	6,5cm.	15,5 cm.	0,37	1



Ergonomica-una mano / Ergo, single one handed use.



▶ **122 Groovy Grip / 122 Groovy Grip**



Groovy Grip

- Thermally treated forged steel jaws,
- Convex jaws.
- Longitudinal V-Groove.

COD	MOD					
53011	122-07"	0-6 cm.	4,4 cm.	20,5 cm.	0,42	1
53012	122-10"	0-6,2 cm.	4,3 cm.	23,8 cm.	0,67	1

▶ **122-12 Bocas gran alcance / 122-12 Large Capacity Plier**



Large capacity Plier

- Thermally treated forged steel jaws.
- Convex jaws. Provides an excellent grip for most screw-in oil filters.

COD	MOD					
53013	122-12*	0-11,2 cm.	9,5 cm.	30 cm.	0,87	1

▶ **127 Grip nariz larga / 127 Long nose grip**



COD	MOD					
53061	127F-06*	0-5,0 cm.	5,2 cm.	17,6cm.	0,24	1
53062	127F-10*	0-6,8 cm.	6,5 cm.	23,2 cm.	0,50	1

Long nose

- Thermally treated forged steel jaws.
- Able to reach deep into recessed areas.

▶ **128 Grip Chapista**
128 Sheet Metal grip



Sheet Metal grip

- Wide jaw profile
- Ideal for bending, shaping, and crimping sheet material.

COD	MOD			L		
53071	128-08"	0-5,5 cm.	4,4 cm.	20 cm.	0,57	1

▶ **125 Grip Horquilla** / 125 Locking U-Grip



Locking U-grip

- Permits the clamping of adjacent pieces and full visibility of the welding area.

COD	MOD			L		
53141	125-09"	0-6 cm.	6,7 cm.	23 cm.	0,69	1
53142	125-12"	0-9 cm.	8,7 cm.	29 cm.	0,94	1

▶ **145 Grip Horquilla de Aluminio**
/145 Locking Aluminium Alloy U-Grip

ALUMINIO
ALUMINIUM



Locking Aluminium Alloy U-grip

- Highly resistant aluminium.
- Doesn't contaminate stainless steel.
- Material resistant to welding blobs

COD	MOD			L		
53191	145-12"	0-8,5 cm.	7,6 cm.	27,3 cm.	0,73	1

▶ **126 Grip Para tubo** / 126 Pipe grip



Pipe grip

- Aligns two adjacent pipes while giving full visibility of the welding area.

COD	MOD			L		
53151	126-12"	0,65-9 cm.	9,3 cm.	29,5 cm.	0,96	1

▶ **124 Grip cuello de Cisne**
124 Locking C-grip



Locking C-grip
-Thermally treated forged steel jaws.
-Deep Jaw Profile.

COD	MOD			L	
53131	124-06"	0-6 cm.	5,0 cm.	17,1 cm.	0,28
53132	124-12"	0-11 cm.	9,2 cm.	28,8 cm.	0,88
53133	124-18"	0-26 cm.	26cm.	47 cm.	1,37
53134	124-24"	0-40 cm.	41cm.	62 cm.	1,69

▶ **224 Grip cuello de Cisne con oscilante**
/224 Locking C-grip with Swivel Pads

Swivel Pads
-Prevents any damage to work pieces.



COD	MOD			L	
53161	224-06"	0-5 cm.	5,8 cm.	17,8 cm.	0,30
53162	224-12"	0-10 cm.	9 cm.	28 cm.	1,15
53163	224-14"	0-15 cm.	13 cm.	35,8 cm.	1,20
53164	224-18"	0-23 cm.	24 cm.	47 cm.	1,42
53165	224-24"	0-37 cm.	40 cm.	63 cm.	1,83

▶ **134 Grip Escotado** /134 Long & Large Reach C-Grip



Long & large Reach C-grip
-Large capacity jaw profile.

COD	MOD			L	
53172	134-20"	0-27 cm.	28,5 cm.	50 cm.	1,80
53173	134-24"	0-8 cm.	40 cm.	58 cm.	3,78
53174	134-28"	0-10 cm.	50 cm.	68,5 cm.	4,11
53175	134-32"	0-12,5 cm.	60 cm.	78,5 cm.	4,46
53176	134-40"	0-16,5 cm.	80 cm.	98,5 cm.	5,10

▶ **144 Grip Escotado de aluminio**
/144 Aluminium Long & Large Reach C-Grip



Aluminium Long & large Reach C-grip
-Large capacity jaw profile to overcome obstacles.
-Highly resistant aluminium
-No stainless steel contamination.

COD	MOD			L	
53181	144-12"	0-11 cm.	9,2 cm.	30 cm.	0,67
53182	144-14"	0-15 cm.	15 cm.	35 cm.	0,90
53183	144-28"	0-10 cm.	50 cm.	68,5 cm.	2,45
53184	144-32"	0-12,5 cm.	60 cm.	78,5 cm.	2,56
53185	144-40"	0-16,5 cm.	80 cm.	98,5 cm.	2,70

▶ 139 Grip de Latiguillos / 139 Hose grip



🇪🇸 Hose grip

-Long rounded smooth section jaws, instant closure with no hose damage.

COD	MOD	🇪🇸	🇬🇧	L	Kg	📦
53081	139-10"	Ø3 cm.	7,7 cm.	23,5 cm.	0,44	1

▶ 137 Grip Tapapuntos / 137 Plugweld Pliers



🇪🇸 Plugweld Pliers

-The solid copper pad on the fixed jaw solves the problem of burn thru when plugwelding thin sheet metal panels.

▶ PAD 137
Repuesto
/Copper pad piece

COD	MOD	🇪🇸	🇬🇧	L	Kg	📦
53111	137-9"	0-3,5 cm.	7 cm.	24,5 cm.	0,51	1

▶ 181 Grip de cadena / 181 Locking chain grip



🇪🇸 Locking chin grip

-Flexible heavy-duty heat treated chain.
-Adjusts quickly around objects of any shape, even in awkward areas.

CAD181 ▶

COD	MOD	🇪🇸	L	Kg	📦
53091	181-10"	Ø4-16cm.	25 cm.	0,90	1
53092	181-12"	Ø4-16cm.	30 cm.	1,14	
53099	CAD181	-	48 cm.	0,31	

▶ 182 Corta tubos de cadena / Chain Pipe Cutter grip



🇪🇸 Chain pipe cutter

-Steel alloy cutting wheels,
-Cuts through steel, copper, PVC...
-Cuts even in awkward areas.

CAD182/6 ▶

COD	MOD	🇪🇸	L	Kg	📦	
53101	182-10"	Ø1,5-7,5cm.	25 cm.	0,83	1	
53102	182-12"	Ø1,5-7,5cm.	30 cm.	1,04		
53108	CAD182	-	38 cm.	0,35		
					Máximo espesor de corte Maximun thickness pipe ▶ 2,6 mm.	
53103	186-12"	Ø2-11,5cm.	32 cm.	1,20	1	
53109	CAD186	-	38 cm.	0,35		
					Máximo espesor de corte Maximun thickness pipe ▶ 5 mm.	

► **MG2K-040 Micro Grip**
MG2K-040 Micro Grip



Micro Grip
-The smallest grip.
-Aluminium and tin.

COD	MOD		L		
53200	MG2K-040	0-1,2 cm.	9,1 cm.	0,12	1



► **Grips Axiales / Axial Grips**



COD	MOD		A	L	
53201	912-07"	0-1,8 cm.	2,0 cm.	19,7 cm.	0,43
53202	915-07"	0-1,5 cm.	4,4 cm.	22 cm.	0,46
53203	918-07"	0-1,0 cm.	4,9 cm.	20 cm.	0,46
53204	922-07"	0-1,5 cm.	2,0 cm.	21 cm.	0,42
53205	925-07"	0-1,5 cm.	4,4 cm.	23,5 cm.	0,50
53206	928-07"	0-1,2 cm.	5,7 cm.	20,2 cm.	0,47



912 Axial Tipo L
-Sujeta dos piezas superpuestas.

912 L-Type Axial
-Clamps two overlapping pieces.



922 Axial Tipo J
-Sujeta dos piezas superpuestas y rebordeadas.

922 J-Type Axial
-Clamps two flanged overlapping pieces.



915 Axial Tipo LL
-Sujeta dos piezas adyacentes.

915 LL-Type Axial
-Clamps two adjacent pieces.



925 Axial Tipo JJ
-Sujeta dos piezas rebordeadas superpuestas o adyacentes.

925 JJ-Type Axial
-Clamps two flanged, overlapping or adjacent pieces.



918 Axial Tipo T
-Sujeta a escuadra dos piezas del mismo espesor.

918 T-Type Axial
-Clamps two pieces of equal thickness at 90°.



928 Axial Tipo W
-Permite soldar cuatro puntos consecutivos sin desmontar la herramienta.

928 W-Type Axial
-Clamps overlapping pieces allowing four consecutive spot welds without removing the tool.

▶ **222 Grip de mesa / 222 Table C-clamp**



Table C-clamp
 -Knurled swivel pad.
 -2 positions fixes and holds objects for drilling welding etc.

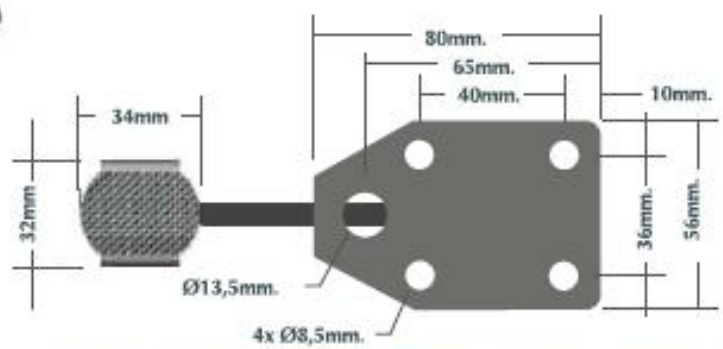

COD	MOD			L	
53121	222-12"	0-10 cm.	7,8cm.	30 cm.	0,88

▶ **1010 Soporte de Grip 10" / 1010 10" Grip Holders**



Grip Holders
 -Convert 10" tools into MINI-PORTABLE VICES.



COD	MOD			L	
53220	1010	0-6 cm.	2,7 cm.	13-19 cm.	0,24

▶ **Kit manos libres / Hands Free Kit**



Hands Free Kit
 -A unique concept creating a true hands free bench vice for cutting, gluing, welding...

COD	MOD		SET	COD	MOD
53210	HK-SET4	2,00	2	53042	131-10"
			2	53220	1010

▶ **Grip gran alcance / Long reach grip pliers**



General Servi Set
-Double pressure mechanism.

COD	MOD	MOD	MOD	MOD
52304	12 cm	6,5 cm	5,7 cm	1
52305	20 cm	6,5 cm	5,7 cm	

▶ **Kit básico / General Service Set**



COD	MOD	Kg	MOD
53211	BS-SET3	1,43	1

SET	COD	MOD
1	53061	127F06*
1	53051	112-07*
1	53032	121-10*

General Servi Set
-Provided in a practical pastic pouch including the most commonly used keys.

▶ **Kit de garage / Garage Set**



COD	MOD	Kg	MOD
53212	CK-SET3	1,85	1

SET	COD	MOD
1	53011	122-07*
1	53012	122-12*
1	53081	139-10*

Garage set
-Especially for general car maintenance, oil filter servicing, brake repairs etc.