

CONTAINER CARRIER CC-40-3-S

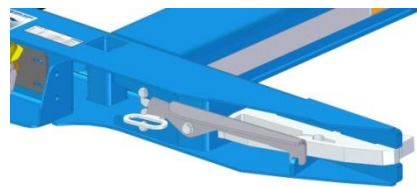

Technische gegevens

Geschikt voor

Schoteldruk

Maximale aslast per as

Totaal toegestane massa

Leeggewicht

Nuttig laadvermogen

Schotelhoogte

Chassishoogte

Bandenmaat

Elektrische aansluitingen

Terug naar rijhoogte



Technische Daten

Geeignet für

Sattellast

Max. Achslast pro Achse

Gesamt zulässige Masse

Leergewicht

Nutzlast

Sattelhöhe

Chassishöhe

Reifengröße

Elektrische Anschlüsse

Zurück zur Fahrhöhe



Technical data

Suitable for

Kingpin weight

Maximal Axleload / axle

Gross trailer weight

Empty weight

Payload

Fifthwheel height

Chassisheight

Tyresize

Electrical connectors

Reset to Ride (RTR)

CC-40-3-S

40ft HC

14.000 kg

9.000 kg

41.000 kg

3.700 kg

37.300 kg

1.110 mm

1.110 mm

385/55 R22,5

2x 7-pin + 1x 15 pin

(>16 km)

OPTIES / OPTIONEN / OPTIONS

17-7-2

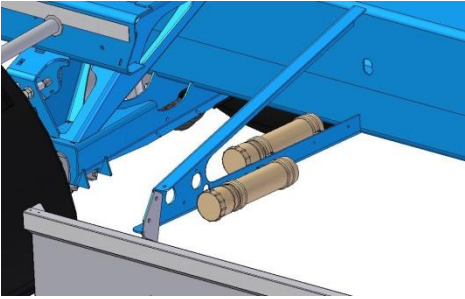

21-10

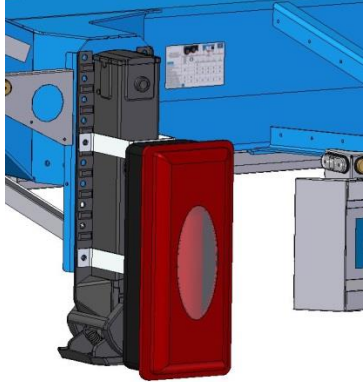

07-5

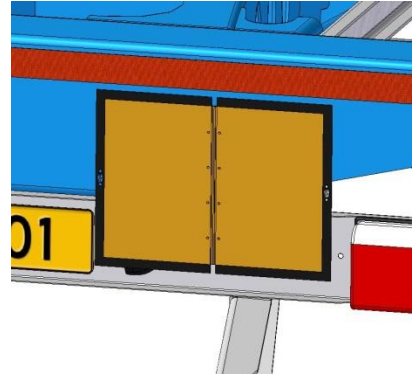

21-8

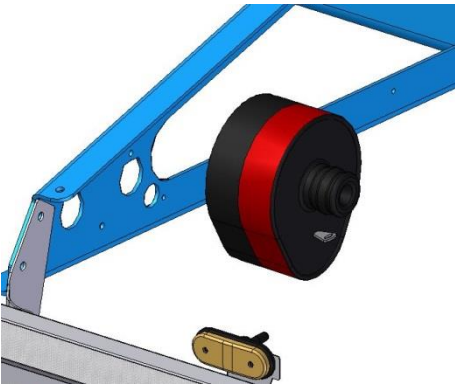

07-28



21-22



07-NS-17

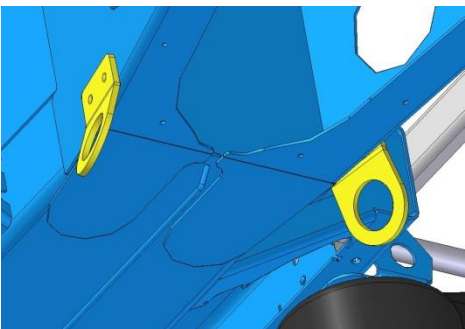

07-NS-17

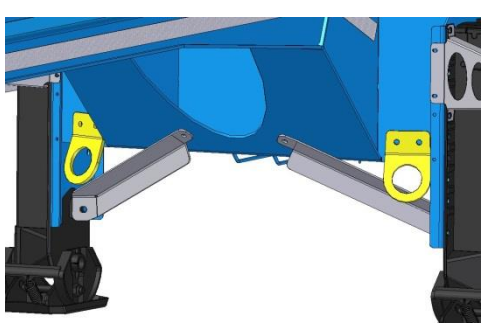

09-5-13

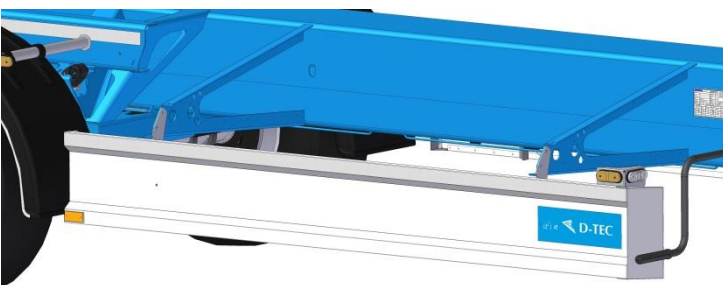

21-16

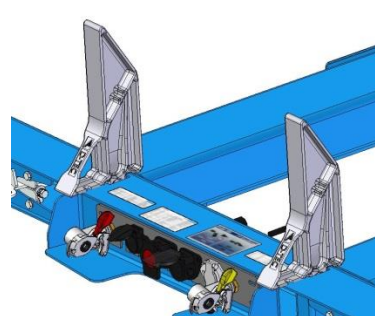

			
	Basis opties	Basis Optionen	Basic options
11-4-15	Valx trommelremmen	Valx Trommelbremsen	Valx drumbrakes
19-B	Banden DoubleStar	Reifen DoubleStar	Tyres DoubleStar
09-6-DTM 5015	1 laag 2K natlak RAL 5015	1 Schicht 2K RAL 5015	1-Layer coating 2K RAL 5015
21-16	Containerstops	Containerstops	Containerstops
	Comfort opties	Komfort Optionen	Comfort options
	VALX / Mercedes-Benz / SAF schijf	VALX / Mercedes-Benz / SAF Scheibe	VALX / Mercedes-Benz / SAF disc
	BPW trommelremmen	BPW Trommelbremsen	BPW drumbrakes
	Hankook / Continental HTR2 /	Goodyear LHT II / Bridgestone	Michelin XTE3
	Standard Coating in RAL 3002,	RAL 5002, RAL 5010, RAL 5015,	RAL 7016, RAL 7021, RAL 9005
09-1-1	Volledig schooperen	Völlig spritzverzinkt	Full schooping
09-1-2	Bovenzijde schooperen	Oberseite spritzverzinkt	Topside schooping
09-5-13	Dichte zijafscherming in kleur wit	Unterfahrschutz in Farbe Weiß	Side protection, colour white
09-5-14	Dichte zijafscherming in chassis kleur	Unterfahrschutz in Chassis Farbe	Side protection, chassis colour
07-3	Kingpenslohouder	Halter für Königszapfenverriegelung	Holder for kingpinlock
07-5	Gevaarlijke stoffen bord	Gefahrgutschild	ADR sign at the rear, orange
21-5	2 Wielkeggen	2 Radkeile	2 Wheelwedges
17-7	Plastic documentenkoker	Dokubox Kunststoff	Document tube
17-7-2	Plastic documentenkokers (2x)	Dokuboxen Kunststoff (2x)	Document tubes (2x)
21-8	Kingpinslot	Königszapfenverriegelung	Kingpinlock
21-10	Houder zonder 6 kg brandblusser	Halter ohne 6kg Feuerlöscher	Holder without 6kg fire extinguisher
07-28	A-bord	A-Schild	A-Board
03-4-A	ADR-fabrikantverklaring	ADR Herstellerbestätigung	ADR Manufacturer certificate
07-NS-17	Ferry ogen	Ferry Verzurringe	Ferry rings
11-FT-1	As 1 liftas automatisch	Achse 1 Liftachse automatisch	Axle 1 liftaxle automatic
21-22	Ophangsteun containerstops	Behälter Containerreinweiser	Support for containerstops

