



LITEBOX trenching system

the flexible aluminium trench lining system

Benefits:

- light weight
- simple assembly
- fast installation
- 10 different plan formats for manholes
- safe and stable

The complete system for installing underground services in trenches as deep as 3 m in urban situations.

Ideal for laying cables, water and gas pipes, service pipes or cables, manholes, and repair or inspection work.



The easy-to-use lightweight aluminium trench and manhole lining system for urban situations

The LITEBOX trenching system is the ideal solution for lining trenches as deep as 3 m in urban environments.

It can be used for all customary trench lining works such as for the laying cables, water and gas pipes, service pipes or cables, manholes, and repair or inspection work.

The system is also ideal for the thrust and reception pits for underground pipe jacking, and for end linings in services trenches.

The LITEBOX trenching system is suitable for all types of soil.

In stable soils:
lining installed as complete unit and withdrawn panel by panel.

In non-plastic and running soils:
partial excavation to allow the assembly of a manhole ring, lowering the manhole corners and aluminium panels alternately with the excavation, individual panels may be omitted, removal from the bottom up is possible.





The individual components of the LITEBOX trenching system



Aluminium panels

Sizes:

- 3000 x 500 x 50 mm weight approx. 42 kg
- 2000 x 500 x 50 mm weight approx. 28 kg
- 1550 x 500 x 50 mm weight approx. 23 kg
- 910 x 500 x 50 mm weight approx. 15 kg

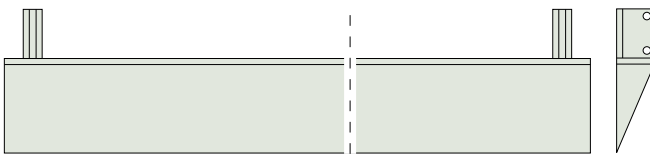

Cutting panel

3000 mm, steel, weight approx. 29 kg



3-D lifting eye

safe working load: 10 kN



Lifting eye for manhole corners

for manhole corners

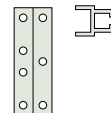

Panel connector

280 mm, weight approx. 2.10 kg

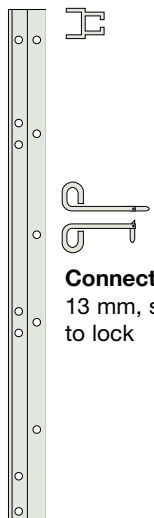

Connecting pin

13 mm, simply turn to lock

Long connector

1350 mm, for 0.75 m clearance below bottom strut, weight approx. 6.30 kg

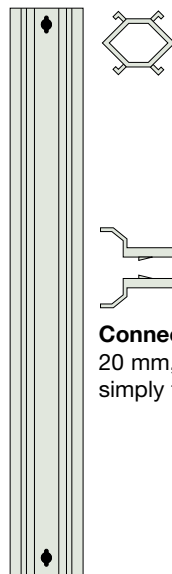

Connecting pin

20 mm, self-locking, simply turn to lock

Manhole corner

1.50 m, weight approx. 11 kg

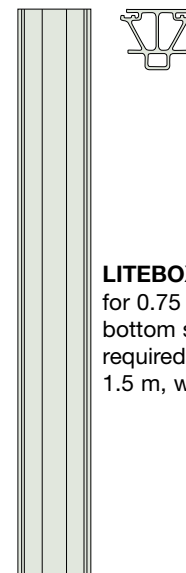

LITEBOX strongrail

for 0.75 m clearance below bottom strut, only 2 struts required per slot-in post, 1.5 m, weight approx. 17 kg

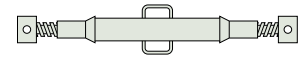

Gi-A struts

with 2 connecting pins, fast, infinite adjustment

Designation system:

o/a dim. of lining without coupler
o/a dim. of lining with coupler
safe working load depending on spindle travel weight

Gi-A / 60 - 81
0.60 - 0.81 m
0.68 - 0.89 m
103.5 - 56.4 kN
5.50 kg

Gi-A / 80 - 121
0.80 - 1.21 m
0.88 - 1.29 m
98.9 - 56.1 kN
7.35 kg

Gi-A / 129 - 218
1.29 - 2.18 m
1.37 - 2.26 m
84.3 - 44.2 kN
11.49 kg

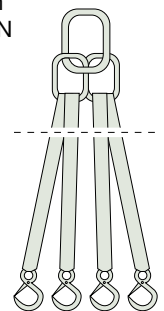

Lifting sling

4 hooks, belt length 2.50 m, approx. 4 kg, safe working load: 10 kN



Strut spanner

500 mm, for easy adjustment of struts

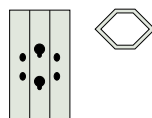

Coupler for manhole corner, 300 mm, weight approx. 1.40 kg

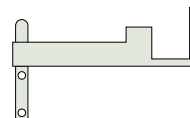

Support bracket

with 2 connecting pins, 13 mm



Guardrail post

simply inserted into bracket

The variable lining system for trenches and manholes as deep as 3 m

The statistics of the German Civil Engineering Employers' Insurance Liability Association (TBG) confirm that the majority of fatal accidents take place in unsupported trenches no deeper than 3 m. In such shallow trenches about 2 m deep, the danger of collapsing soil masses is underestimated and trench lining is not installed.

The well-known trench lining systems made of steel are unfortunately often too heavy, too complicated to use, oversized for these shallow trenches and always need an excavator for lifting and installation. Up until now there was no alternative to the well-known steel trench lining systems or manually installed timber planks, 280 x 50 mm, 4.5 m long, which have to be propped at four places and additionally weigh approx. 40 kg.

Lightweight aluminium lining systems are used most frequently for trenches no deeper than 1.75 m – the majority of buried services can be found within this depth – as a trenchbox providing top support only. The top edges of the trench are therefore protected against collapse.

In urban environments it is important to minimise the disruption to roads and footpaths, and damage the existing pavements as little as possible. Two operatives can carry a trenchbox – weighing approx. 90 kg – and place it in the preliminary excavation. The excavator – frequently only a backacter with max. 1 t lifting capacity – can continue with the excavation work and is not disrupted for transporting, installing and removing trench lining items. The unobstructed working space between the struts is 2.85 m when using 3 m aluminium panels,

Situation A

| | |
|--------------------|--------|
| Trench depth | 1.75 m |
| No. of panels | 2 |
| No. of struts | 4 |
| Connectors: 0.28 m | - |
| Connectors: 1.35 m | - |

Max. weight

| | |
|---------------|---------------|
| with struts | Gi-A /129-218 |
| 3.00 m panels | 130 kg |
| 2.00 m panels | 103 kg |
| 1.55 m panels | 93 kg |

Situation B

| | |
|--------------------|--------|
| Trench depth | 1.50 m |
| No. of panels | 6 |
| No. of struts | 4 |
| Connectors: 0.28 m | - |
| Connectors: 1.35 m | 4 |

Max. weight

| | |
|---------------|---------------|
| with struts | Gi-A /129-218 |
| 3.00 m panels | 325 kg |
| 2.00 m panels | 242 kg |
| 1.55 m panels | 213 kg |

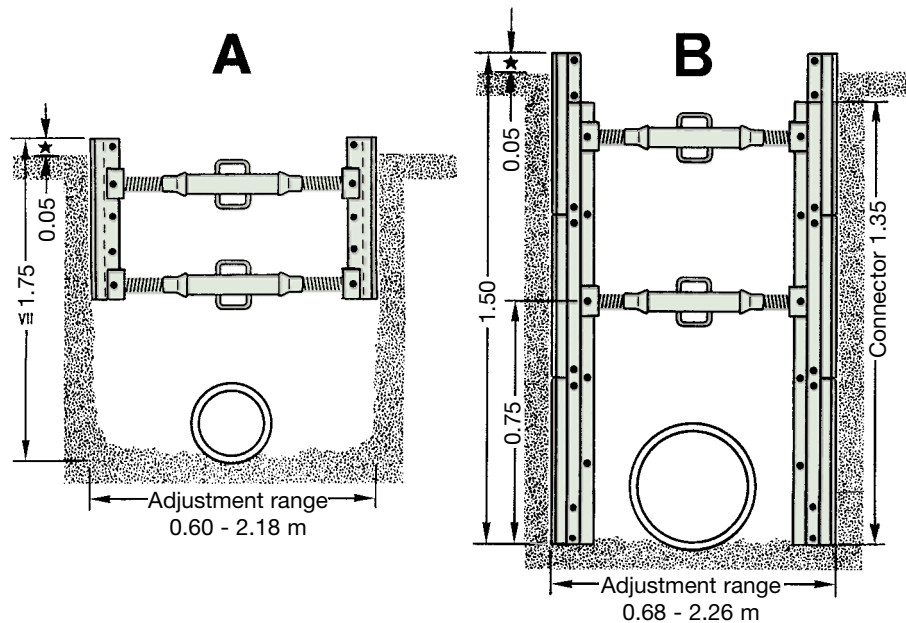

meaning that there is ample room for excavating and pipelaying.

Trenches between 1.75 and 3 m deep require full-depth linings. The aluminium panels are rigidly joined together with the connectors to form large-format trench lining units so that re-strutting during pipelaying is also possible.

The aluminium panels weigh no more than 42 kg and so they are easy to move manually in order to avoid pipes and cables crossing the trench.

Aluminium panels can be transported on small trucks and loaded/

unloaded by hand. Such systems are ideal for the repair crews of gas, water and electricity supply companies.

Another worthwhile feature is the system's integral guardrail posts. In urban areas, contractors and gas, water and electricity supply companies must employ all possible means to protect third parties (passers-by) against injury or damages. Those measures include proper signs, lighting and safety barriers plus minimal disruption to and narrowing of roads and footpaths.

Situation C

| | |
|--------------------|--------|
| Trench depth | 2.00 m |
| No. of panels | 8 |
| No. of struts | 4 |
| Connectors: 0.28 m | 4 |
| Connectors: 1.35 m | 4 |

Max. weight

| | |
|---------------|---------------|
| with struts | Gi-A /129-218 |
| 3.00 m panels | 417 kg |
| 2.00 m panels | 307 kg |
| 1.55 m panels | 268 kg |

Situation D

| | |
|--------------------|--------|
| Trench depth | 2.50 m |
| No. of panels | 10 |
| No. of struts | 6 |
| Connectors: 0.28 m | 8 |
| Connectors: 1.35 m | 4 |

Max. weight

| | |
|---------------|---------------|
| with struts | Gi-A /129-218 |
| 3.00 m panels | 532 kg |
| 2.00 m panels | 394 kg |
| 1.55 m panels | 346 kg |

Situation E

| | |
|--------------------|--------|
| Trench depth | 3.00 m |
| No. of panels | 12 |
| No. of struts | 6 |
| Connectors: 0.28 m | 4 |
| Connectors: 1.35 m | 8 |

Max. weight

| | |
|---------------|---------------|
| with struts | Gi-A /129-218 |
| 3.00 m panels | 635 kg |
| 2.00 m panels | 469 kg |
| 1.55 m panels | 411 kg |

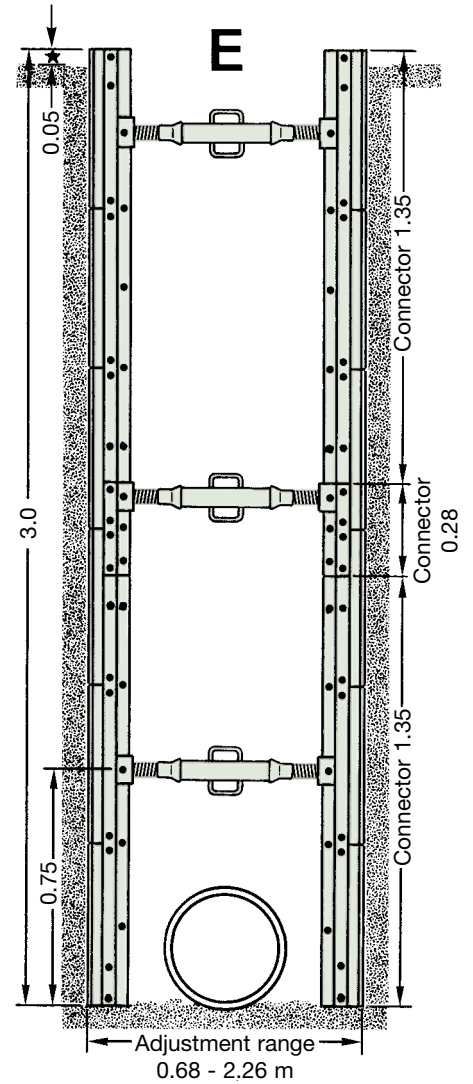
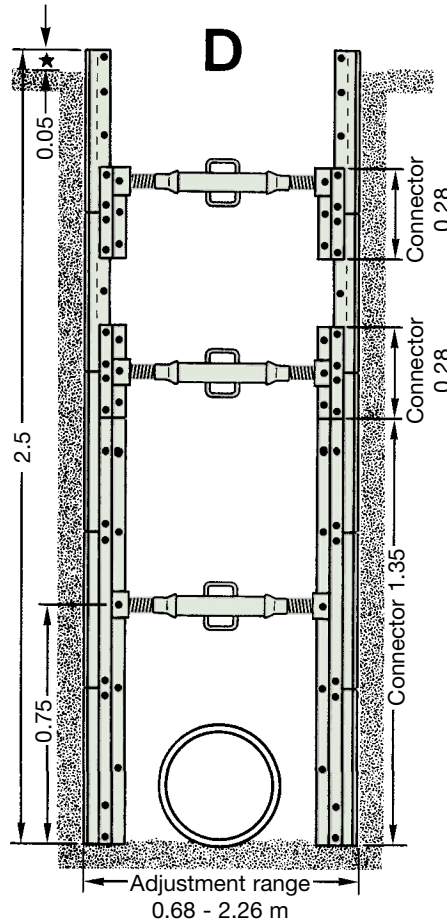
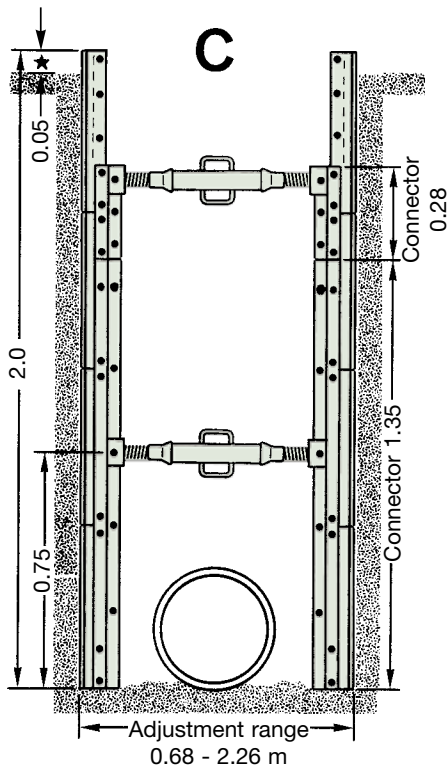

* 0.05 m projection required by DIN 4124



Tighten and release with the strut spanner



3-D lifting eye for attaching lifting sling



Panel-by-panel withdrawal of manhole corners



Support bracket for securing the trench lining against slippage

Technical specification

Earth pressure according to German Civil Engineering Employers' Insurance Liability Association (TBG))

| Trench depth [m] | ≤ 3 | 4 | 5 | 6 | 7 |
|---|------|------|------|------|------|
| Earth pressure e_k [kN/m ²] | 17.5 | 23.0 | 28.6 | 34.1 | 39.7 |

Trench lining

average weight approx. 30 kg/m²

| Aluminium panels | 3.00 x 0.50 | 2.00 x 0.50 | 1.55 x 0.50 | 0.91 x 0.50 |
|---|-------------|-------------|-------------|-------------|
| Permissible trench depth [m] | 3.00 | 6.00 | 6.00 | 6.00 |
| Centre-to-centre spacing of struts along length of trench [m] | 2.85 | 1.85 | 1.40 | 0.76 |
| Unobstructed clearance below bottom strut [m] | 0.75 | 1.10 | 1.10 | 1.10 |

Note: When re-strutting during pipelaying, the maximum permissible spacing of struts may not exceed 1.15 m.

Manholes

10 different plan formats available

| | | | |
|------------------------------|------------------------------|------------------------------|------------------------------|
| 3.00 x 3.00 (3.20 x 3.20) | – | – | – |
| 3.00 x 2.00 (3.20 x 2.20) | 2.00 x 2.00 (2.20 x 2.20) | – | – |
| 3.00 x 1.55 (3.20 x 1.75) | 2.00 x 1.55 (2.20 x 1.75) | 1.55 x 1.55 (1.75 x 1.75) | – |
| 3.00 x 0.91 (3.20 x 1.11) | 2.00 x 0.91 (2.20 x 1.11) | 1.55 x 0.91 (1.75 x 1.11) | 0.91 x 0.91 (1.11 x 1.11) |

Dimensions in () = external size of aluminium manhole lining
Permissible clearance below bottom strut in manhole = 1.00 m

LITEBOX trenching system complies with German standards DIN 4124 and DIN EN 13331.

LITEBOX trenching system is tested for **safe working conditions** by the specialist committee of the German Civil Engineering Employers' Insurance Liability Association (TBG).

Always follow the instructions!

Initial assembly on the building site

The elements are simply fitted together with the self-locking connecting pins. The work can be carried out manually without the need for lifting equipment.

When installing struts, make sure that the spindles are extended equally on both sides and that all spindles with left-hand threads (black) are placed on one side, all spindles with right-hand threads (galvanised) on the other.

Aluminium manhole lining

- with 10 different plan formats
- for pipe repairs and routine inspections
- for the thrust or reception pits in underground pipe jacking operations
- for end linings in pipe trenches

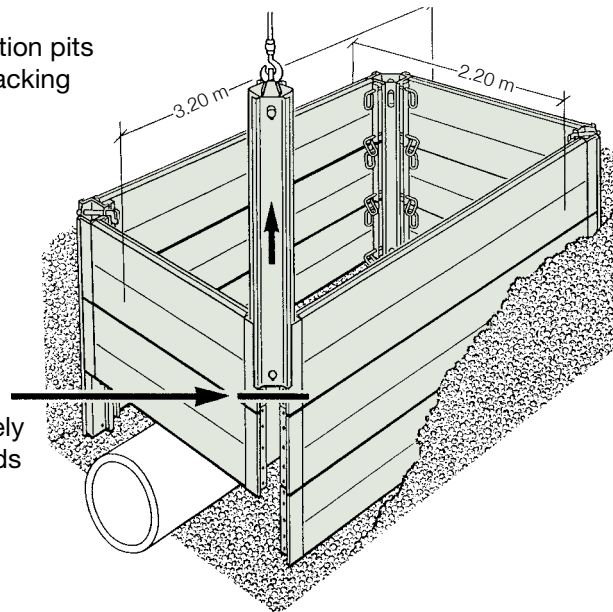

The aluminium panels are removed successively from the bottom upwards as the manhole corner posts are raised

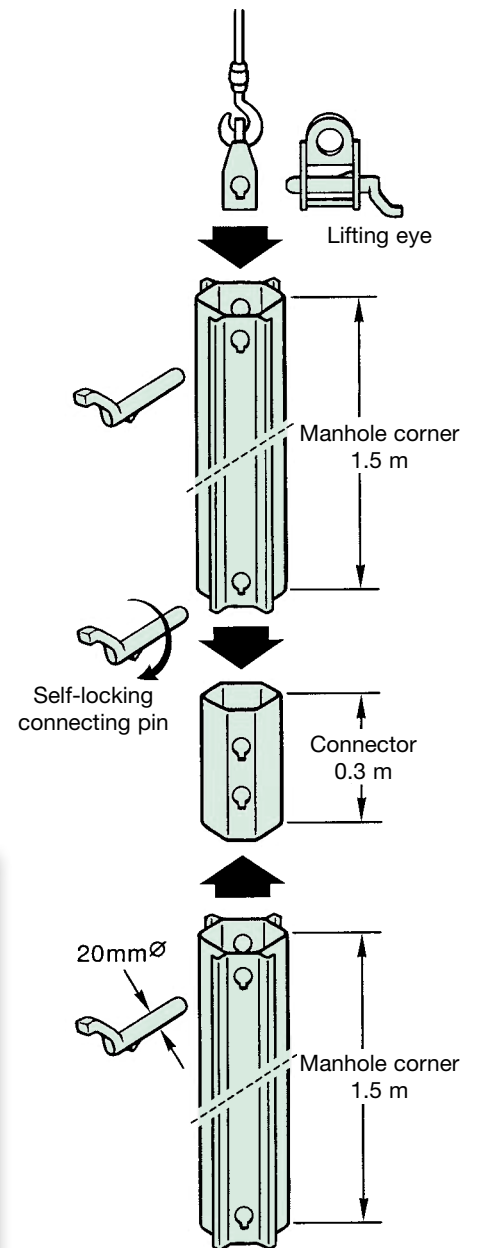

Renewal of road gullies



Aluminium manhole lining

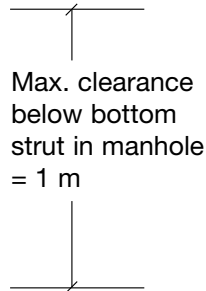

One side omitted for working on a basement wall section by section

Used as trenchbox providing top support only



Special solution

for laying long pipes – 12 m long, 0.3 m diameter – in a 1.75 m deep trench without re-strutting

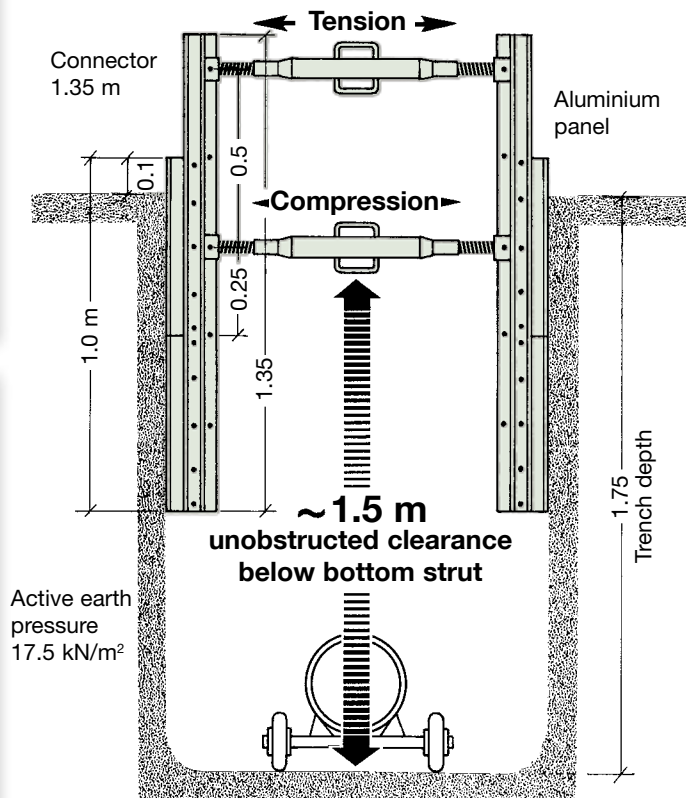

When using LITEBOX strongrail, either side of the trench lining can be installed or removed separately. This halves the force required to install or remove panels, which helps to preserve the panels and speed up the work.

The use of LITEBOX strongrails halves the number of struts required compared to the use of panels supported at their ends. Fewer struts means savings in materials, advantages during excavation and when re-strutting during pipelaying.



Connector suitable for aluminium panel and LITEBOX strongrails



3-D lifting eye suitable for aluminium panel connector and LITEBOX strongrails



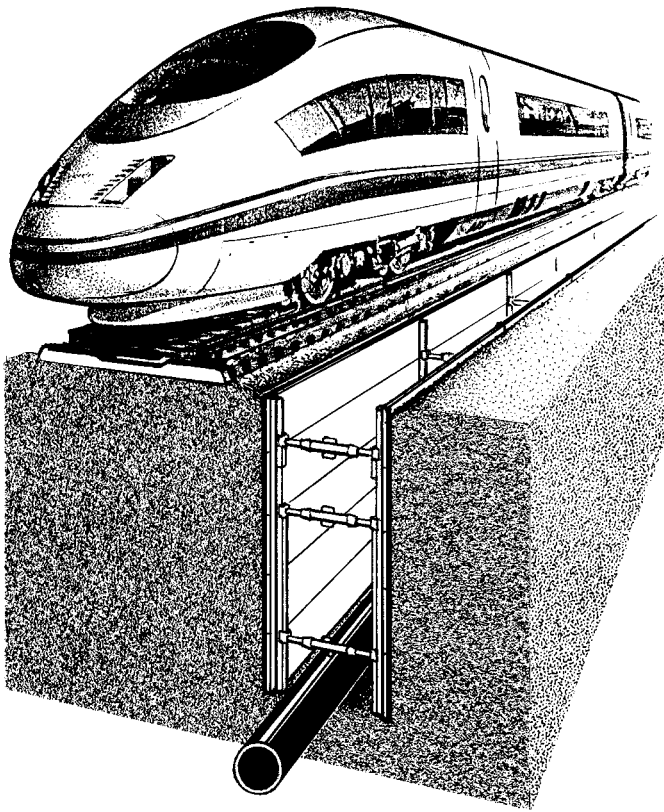

LITEBOX trenching system lining adjacent to railway tracks

When excavating trenches for pipes and cables in the vicinity of railway tracks, you need a trench lining system that can be installed manually. With its low weight and fast, simple installation, lightweight aluminium trench lining is the ideal solution here.

The analysis of the installation examples given here for trenches adjacent to railway tracks was carried out using the loading assumptions of DIN 1054 for the self-weight of the soil and DIN Special Report 101 (loading case 71) for the surcharges due to railway traffic.

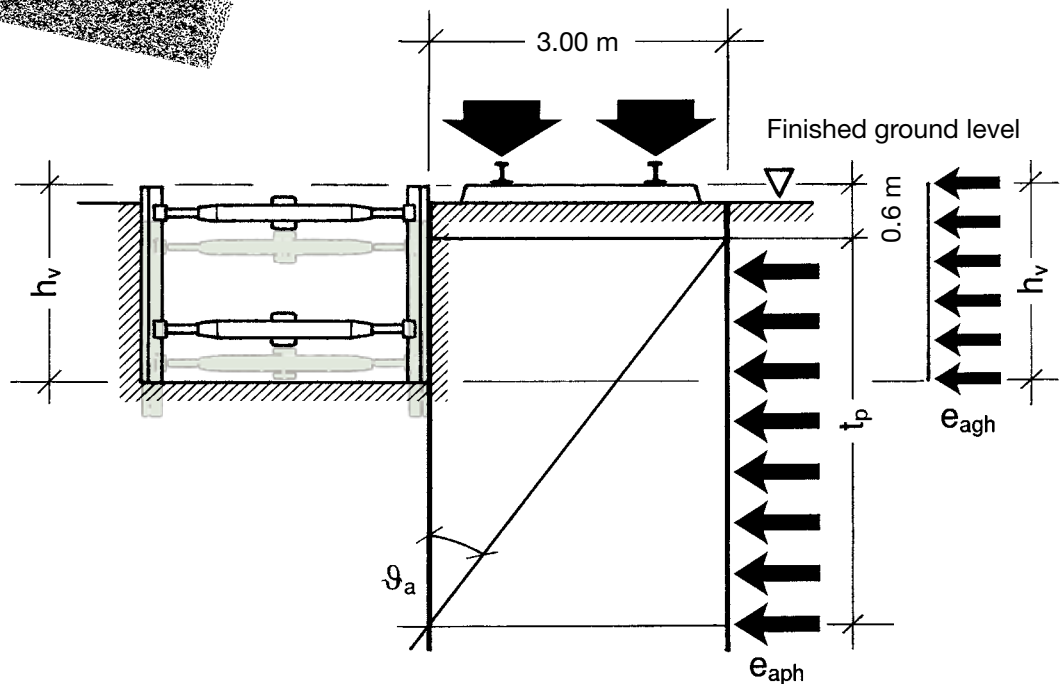

Overview of potential applications for the LITEBOX aluminium trench lining system when subjected to railway loads

| Trench depth [m] | Angle of friction of soil [°] | Aluminium panel width [m] | |
|------------------|-------------------------------|---------------------------|--------|
| | | 2.00 m | 1.55 m |
| 2.00 | 25 | not possible | ok |
| | 30 | ok | ok |
| | 35 | ok | ok |
| 2.50 | 25 | not possible | ok |
| | 30 | not possible | ok |
| | 35 | ok | ok |
| 3.00 | 25 | not possible | ok |
| | 30 | not possible | ok |
| | 35 | ok | ok |

Assumptions:

| | | |
|---------------------------|--------------------------|----------------------|
| Inclination of wall | $\alpha = 0$ | [°] |
| Inclination of ground | $\beta = 0$ | [°] |
| Angle of wall friction | $\delta_a = 0$ | [°] |
| Slip plane angle | $\nu_a = 45 + \varphi/2$ | [°] |
| Unit weight of soil | $\gamma = 20$ | [kN/m ³] |
| Distance to railway track | $a = 0$ | [m] |

The struts are to be installed according to the appropriate installation examples for railway loads.

LITEBOX trenching system lining adjacent to railway tracks
Verified structural calculations



Trench depth 2.00 m

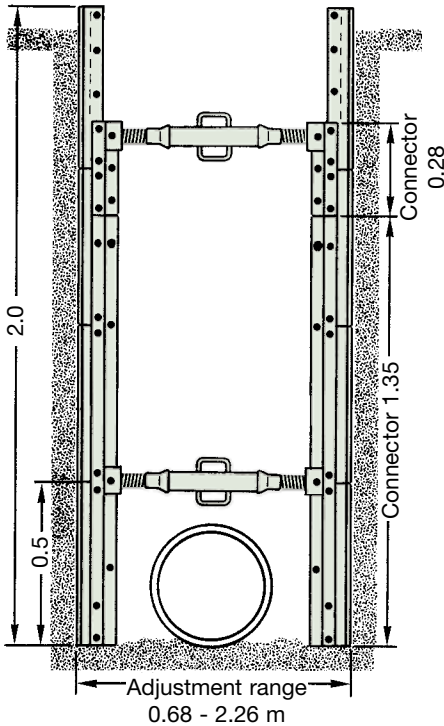

Trench depth 2.50 m

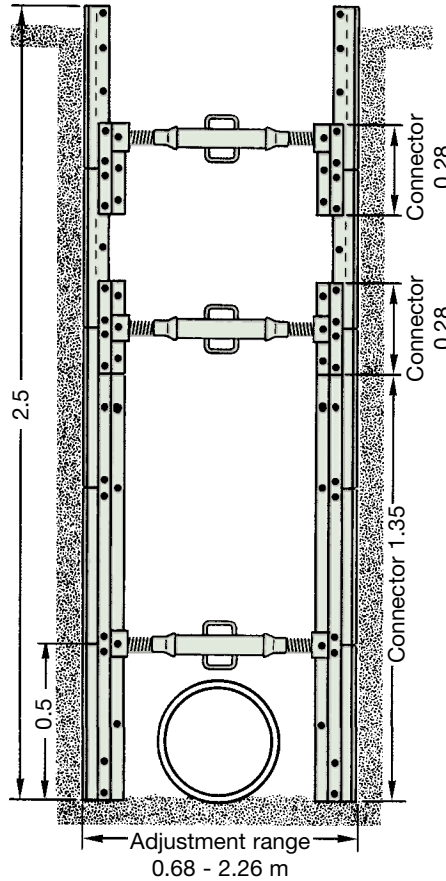

Trench depth 3.00 m

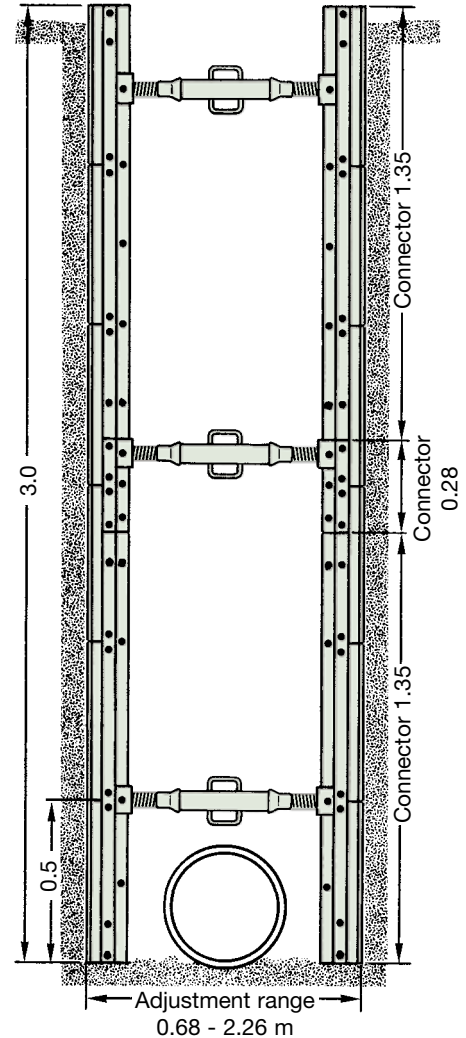

Installation examples for trench lining adjacent to railway tracks

Trench depth 2.00 m, 2.50 m, 3.00 m
 Use of aluminium panels 1.55 m long
 Uniform soil with $\gamma = 20 \text{ kN/m}^3$
 Angle of friction ϕ between 25° and 35°

7.3 Summary

The calculations have been checked by way of independent comparative calculations. Stability and deformation are in compliance with the requirements. There are no objections to this method provided the aforementioned stipulations and conditions are adhered to.

Iserlohn, 22 Aug 1986

Dipl.-Ing. Wolfgang Pluth
 SV für bautechnische Prüfung
 im Eisenbahnbau Nr. 21/02/1036

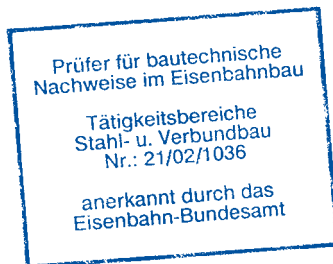

Encs: Structural calculations with annexes 1- 8



Special solution: manhole lining with additional struts



Lightweight aluminium trench lining with 0.54 x 0.5 m opening

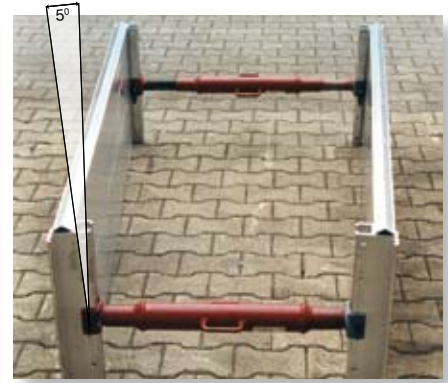

The struts allow the sides to be inclined at an angle of up to 5°.



A combination of 3.0 m, 1.55 m and 0.91 m aluminium panels enables an opening to be formed



Aluminium panels as formwork for a pocket foundation

DIN EN ISO 9001



ISCHEBECK® . . . technically advanced formwork, shoring, trenching and geotechnical systems

FRIEDR. ISCHEBECK GMBH · P. O. Box 13 41 · DE-58242 ENNEPETAL
 TEL. (023 33) 83 05-0 · FAX (023 33) 83 05-55 · E-MAIL: info@ischebeck.de · <http://www.ischebeck.de>
 Principal office Ennepetal · Amtsgericht Hagen HRB 5585 · VAT Id.-Nr.: DE811161225 · Joint managing directors Dipl.-Ing. Ernst Friedrich Ischebeck, Friedrich Döpp, Dipl. Wi.-Ing. Björn Ischebeck

