

# Industrial ball valves

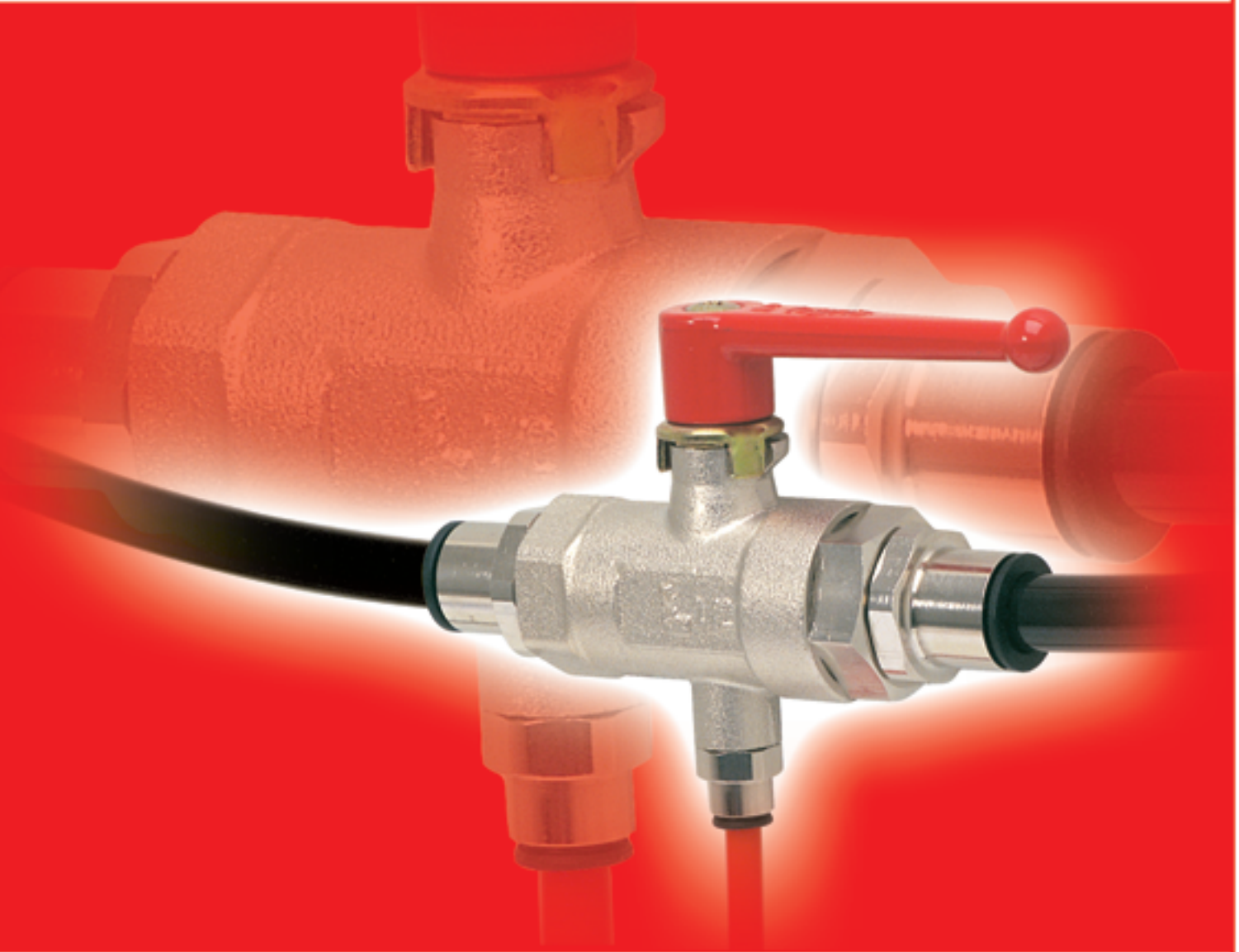

# Industrial ball valves

Legris provides a wide range of ball valves, adapted to many applications, and suited to a variety of customer requirements in terms of performance.

## Ball valves Industrial series



- suitable for pressures up to **300 bar**
- excellent sealing at low and high pressure
- secure non removable inlet and outlet ports
- handle replaceable by a wheel

## Ball valves Semi-standard series

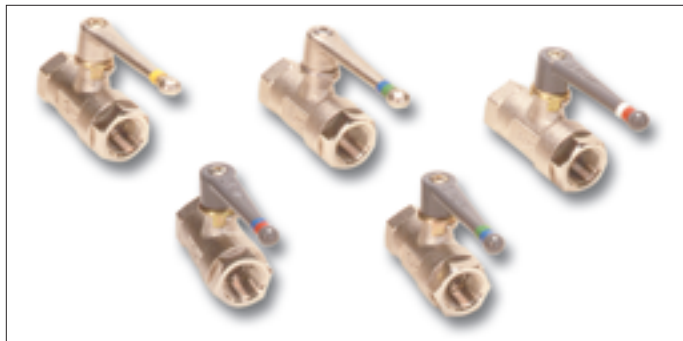

- to satisfy specific customer requirements
- 6 versions cover virtually all requirements for different types of fluids and applications

## Needle valves



- compact and designed for use where a combination of fluid control and **perfect sealing** is required
- various configurations, connection types and dimensions

## Needle valves: accessories



- needle drain valves
- venting pressure gauge valves
- pressure relief valve

## Axial valves



- overcome the limitations of traditional actuators
- **excellent** performance
- compatible with numerous industrial fluids
- straightforward reliable installation

On pages R24 to R27, an application table enables correct choice of valve depending on the fluid used.

# Industrial ball valves

The variety of this range provides an answer to many specific requirements. Select the model required for your application.

## Ball valves Standard range, 2 and 3 way



- for all industrial applications
- long life
- in-line, with right angled flow and screw fixing versions

## Ball valves Standard range, lockable

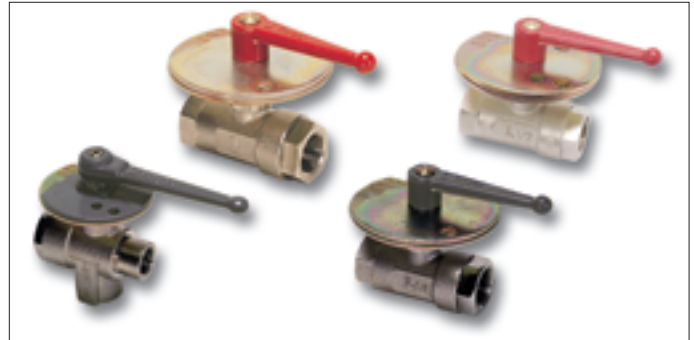

- for **safety** of personnel and equipment
- valves are lockable:
  - in both open and closed position
  - only in the closed position

## Ball valves Standard range, vented

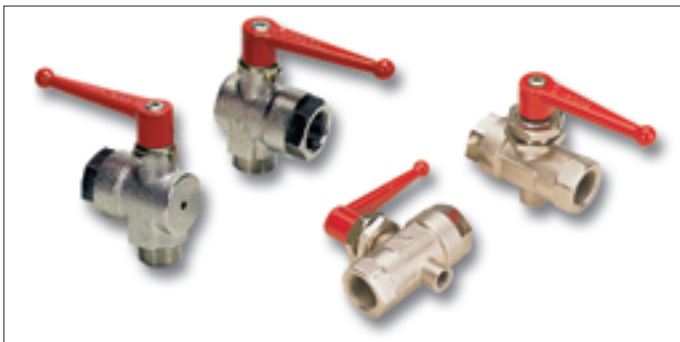

- with threaded exhaust, to allow discharge of downstream media
- with pin-hole vent, for applications with no special discharge requirement
- fluid flow direction

## Ball valves Light series

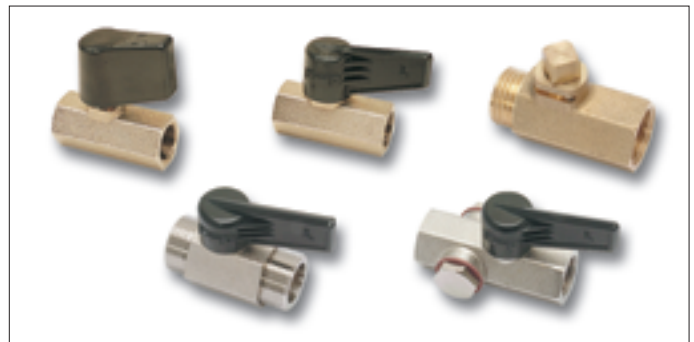

- allow the passage of many fluids
- suited to medium pressures and temperatures
- models with standard handle and with a square stem

## Ball valves Fluoropolymer series



- suitable for many applications requiring **PTFE seals**
- both high quality and good value
- **H.R.** range, guaranteed silicone free
- **economy** range with standard handle and butterfly handle

## Ball valves Stainless steel series



- designed for use with **corrosive** fluids
- resistance to **aggressive** environments
- with ball, one piece, "3-piece" and needle types

# the complete range of ball valves



## in-line ball valves

**0402**  
Page R7



**0401**  
Page R7



**0400**  
Page R7



**0411**  
Page R7



**0414**  
Page R7



## in-line with fixing holes and panel mounting

**0446**  
Page R8



**6402**  
Page R8



**6401**  
Page R8



## right-angled ball valves

**0472**  
Page R9



**0471**  
Page R9



## in-line ball valves – 3 way

**0482**  
Page R10



**0483**  
Page R10



**0448**  
Page R10



**0452**  
Page R10



## light series

**0492**  
Page R11



**0491**  
Page R11



**0490**  
Page R11



**0494**  
Page R11



## light series with square stem

**0497**  
Page R12



**0496**  
Page R12



## lenticular valves

**4602**  
Page R12



## in-line fluoropolymer series

**4902**  
Page R13



**4905**  
Page R14



**4906**  
Page R14



**4900**  
Page R15



**4903**  
Page R15



**4901**  
Page R15



**4904**  
Page R15



## lockable ball valves

**0432**  
Page R16



**0438**  
Page R16



**0437**  
Page R17



**0439**  
Page R17



## venting ball valves

**0489**  
Page R18



**0449**  
Page R18



**0469**  
Page R18



## standard vented, with right angled flow

**0462**  
Page R19



**0461**  
Page R19



## high pressure ball valves

**4402**  
Page R20



# the complete range of ball valves

## stainless steel ball valves

**4832**  
Page R21

**4812**  
Page R21

**4810**  
Page R21



## stainless steel ball valves

**0465**  
Page R22



## needle valves

**0502**  
Page R28

**0501**  
Page R28

**0510**  
Page R28

**0532**  
Page R29

**0531**  
Page R29



## accessories

**0562**  
Page R29

**0563**  
Page R29

**0627**  
Page R29

**0630**  
Page R29



## axial valves

**4202**  
Page R32

**4212**  
Page R32

**4222**  
Page R32



## accessories

**4298**  
Page R33

**4298**  
Page R33

**4299**  
Page R33



## Identification

Part numbers have been chosen by a method of mnemonics. Each valve is identified by :

- its series
- the diameter of passage through the valve
- the thread code

Example

**4902 20 27**

type of ball valve      diameter of passage      thread code



# principle of ball valves

## Standard range



The standard **Legris ball valve** provides a reliable means of opening and closing fluid systems. It requires a simple quarter turn of the handle to operate the two-way version, or a 180° turn for the three way version.

### Principal advantages:

- optimum sealing due to compensating "O" rings
- smooth operation due to low friction coefficient of chemically nickel-plated brass
- excellent resistance to scaling due to ball seal configuration
- **Legris ball valves** provide many thousands of trouble free operations due to the "O" rings compensating for seal wear

### Reliability :

- the **ball** is sealed on both sides by graphite impregnated rilsan seals which are supported by perbunan compensating "O" rings. This ensures that the seal remains in contact with the ball at all times thus extending the life of the ball valve by preventing leakage should seal wear occur.
- the stem is firmly secured within a square insert on the ball and is sealed by an "O" ring.

## technical specifications

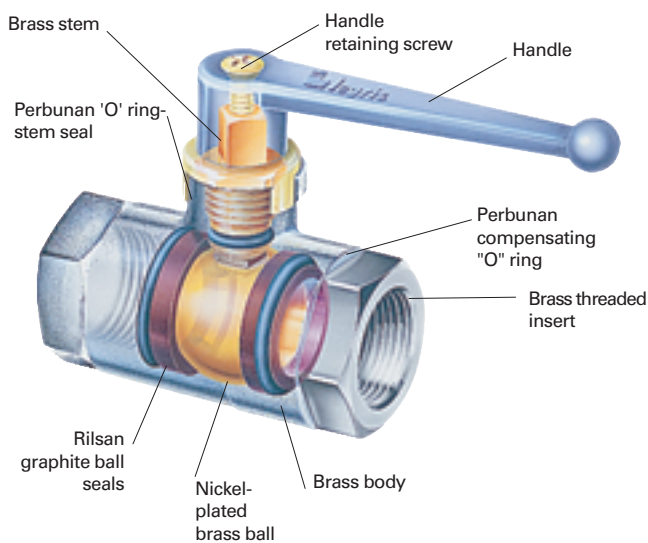

|  |   |              |              |              |              |              |
|--|---|--------------|--------------|--------------|--------------|--------------|
| <b>working fluids</b>  | see application table on pages R24 to R27   |              |              |              |              |              |
| <b>working pressure</b>  | 20 to 40 bar depending on the model   |              |              |              |              |              |
| <b>working temperature</b>                                       | - 20° to + 80°C   |              |              |              |              |              |
| <b>constituent materials</b>                                     | body : sand blasted nickel-plated brass<br>ball : polished brass<br>stem : brass<br>retaining nut : brass<br>ball seal : graphite impregnated rilsan<br>stem seal : nitrile<br>compensating "O" rings : nitrile |              |              |              |              |              |
| <b>maximum tightening torques of ball valves, standard range</b> | thread  | G1/8         | G1/4         | G3/8         | G1/2         | G3/4         |
|  | m.daN   | 0,10 to 0,20 | 0,10 to 0,20 | 0,15 to 0,25 | 0,20 to 0,35 | 0,50 to 0,70 |
|  | thread  | G1"          | G1"1/4       | G1"1/2       | G2"          |              |
|  | m.daN   | 0,50 to 0,70 | 0,40 to 0,60 | 0,80 to 1,20 | 0,80 to 1,20 |              |

# standard in-line ball valves

## 0402 double female



sand blasted nickel-plated brass body

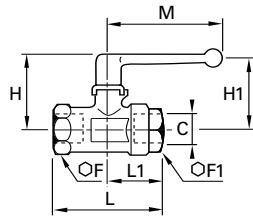

| C      | DN |             | F  | F1 | H   | H1  | L   | L1 | M   | Δkg   |
|--------|----|-------------|----|----|-----|-----|-----|----|-----|-------|
| G1/8   | 4  | 0402 04 10  | -  | 14 | 35  | 29  | 44  | 25 | 48  | 0,091 |
| G1/8   | 7  | 0402 07 10  | 19 | 19 | 38  | 31  | 51  | 27 | 48  | 0,167 |
| G1/4   | 7  | 0402 07 13  | 19 | 19 | 38  | 31  | 53  | 28 | 48  | 0,157 |
| G3/8   | 10 | 0402 10 17  | 24 | 24 | 45  | 43  | 59  | 31 | 69  | 0,230 |
| G1/2   | 13 | 0402 13 21  | 27 | 27 | 47  | 44  | 67  | 34 | 69  | 0,291 |
| G3/4   | 20 | 0402 20 27  | 32 | 38 | 63  | 54  | 80  | 39 | 108 | 0,690 |
| G1"    | 23 | 0402 23 34  | 41 | 46 | 67  | 57  | 94  | 47 | 108 | 1,030 |
| G1"1/4 | 32 | 0402 32 42* | 55 | 60 | 97  | 105 | 112 | 59 | 180 | 2,433 |
| G1"1/2 | 32 | 0402 32 49* | 55 | 60 | 97  | 105 | 120 | 62 | 180 | 2,278 |
| G1"1/2 | 40 | 0402 40 49* | 55 | 55 | 104 | 105 | 111 | 55 | 190 | 2,558 |
| G2"    | 40 | 0402 40 48* | 70 | 70 | 104 | 105 | 122 | 61 | 190 | 2,754 |

\*models with CE marking maximum working pressure : 40 bar

## 0401 male female



sand blasted nickel-plated brass body

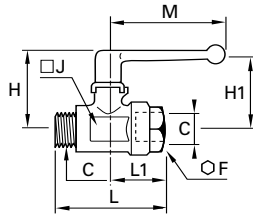

| C      | DN |             | F  | H  | H1  | J  | L   | L1 | M   | Δkg   |
|--------|----|-------------|----|----|-----|----|-----|----|-----|-------|
| G1/8   | 4  | 0401 04 10  | 14 | 35 | 29  | 14 | 45  | 25 | 48  | 0,091 |
| G1/8   | 5  | 0401 05 10  | 19 | 38 | 31  | 19 | 51  | 27 | 48  | 0,158 |
| G1/4   | 7  | 0401 07 13  | 19 | 38 | 31  | 19 | 52  | 28 | 48  | 0,151 |
| G3/8   | 10 | 0401 10 17  | 24 | 45 | 43  | 24 | 58  | 31 | 69  | 0,227 |
| G1/2   | 13 | 0401 13 21  | 27 | 47 | 44  | 27 | 66  | 34 | 69  | 0,290 |
| G3/4   | 18 | 0401 18 27  | 38 | 63 | 54  | 39 | 79  | 39 | 108 | 0,714 |
| G1"    | 23 | 0401 23 34  | 46 | 67 | 57  | 48 | 91  | 47 | 108 | 1,028 |
| G1"1/4 | 32 | 0401 32 42* | 60 | 97 | 115 | 55 | 113 | 59 | 180 | 2,374 |

\*models with CE marking maximum working pressure : 40 bar

## 0400 double male



sand blasted nickel-plated brass body

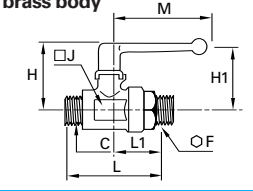

| C    | DN |            | F  | H  | H1 | J  | L  | L1 | M   | Δkg   |
|------|----|------------|----|----|----|----|----|----|-----|-------|
| G1/8 | 4  | 0400 04 10 | 14 | 35 | 29 | 14 | 45 | 25 | 48  | 0,091 |
| G1/4 | 7  | 0400 07 13 | 19 | 38 | 31 | 19 | 60 | 36 | 48  | 0,163 |
| G3/8 | 10 | 0400 10 17 | 24 | 45 | 43 | 24 | 70 | 43 | 69  | 0,251 |
| G1/2 | 13 | 0400 13 21 | 27 | 47 | 44 | 27 | 78 | 45 | 69  | 0,327 |
| G3/4 | 18 | 0400 18 27 | 38 | 63 | 54 | 39 | 90 | 50 | 108 | 0,770 |

maximum working pressure : 40 bar

## 0411 with two couplings fitted for use with steel tube



sand blasted nickel-plated brass body

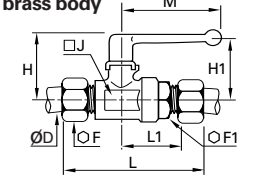

| ØD | DN |            | F  | F1 | H  | H1 | J  | L  | L1 | M  | Δkg   |
|----|----|------------|----|----|----|----|----|----|----|----|-------|
| 6  | 4  | 0411 04 06 | 14 | 19 | 38 | 31 | 19 | 76 | 30 | 48 | 0,183 |
| 8  | 6  | 0411 06 08 | 17 | 19 | 38 | 31 | 19 | 77 | 30 | 48 | 0,182 |
| 10 | 7  | 0411 07 10 | 19 | 19 | 38 | 31 | 19 | 78 | 31 | 48 | 0,207 |
| 12 | 10 | 0411 10 12 | 22 | 24 | 45 | 43 | 24 | 85 | 36 | 69 | 0,312 |

maximum working pressure : 40 bar

## 0414 with two couplings fitted with double taper rings



sand blasted nickel-plated brass body

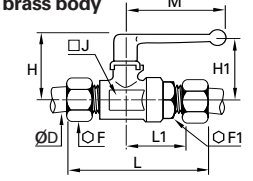

| ØD | DN |            | F  | F1 | H  | H1 | J  | L  | L1 | M  | Δkg   |
|----|----|------------|----|----|----|----|----|----|----|----|-------|
| 6  | 4  | 0414 04 06 | 13 | 19 | 38 | 31 | 19 | 72 | 31 | 48 | 0,179 |
| 8  | 6  | 0414 06 08 | 14 | 19 | 38 | 31 | 19 | 74 | 30 | 48 | 0,181 |
| 10 | 7  | 0414 07 10 | 19 | 19 | 38 | 31 | 19 | 78 | 31 | 48 | 0,210 |
| 12 | 10 | 0414 10 12 | 22 | 24 | 45 | 43 | 24 | 86 | 36 | 69 | 0,305 |

maximum working pressure : 40 bar

length of female threads (E) and male BSPP threads (E1)  
0402 – 0401 and 0400

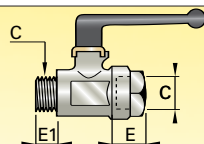

| C  | G1/8 | G1/4 | G3/8 | G1/2 | G3/4 | G1" | G1"1/4 | G1"1/2 | G2" |
|----|------|------|------|------|------|-----|--------|--------|-----|
| E  | 8    | 12   | 12   | 15   | 16,5 | 19  | 21,5   | 22     | 26  |
| E1 | 7    | 9    | 11   | 12   | 12   | 15  | 18     |        |     |

# standard ball valves for screw fixing and panel mounting

## 0446 double female - panel mounted



sand blasted nickel-plated brass body

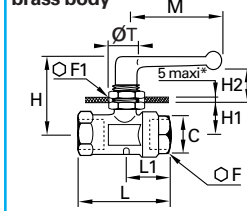

| C    | DN |            | F  | F1 | H  | H1 | H2 | L  | L1 | M  | T    | $\Delta$ kg |
|------|----|------------|----|----|----|----|----|----|----|----|------|-------------|
| G1/8 | 4  | 0446 04 10 | 14 | 22 | 37 | 14 | 12 | 44 | 25 | 48 | 16,5 | 0,101       |
| G1/4 | 7  | 0446 07 13 | 19 | 24 | 45 | 19 | 14 | 53 | 28 | 48 | 20,5 | 0,189       |
| G3/8 | 10 | 0446 10 17 | 24 | 27 | 50 | 21 | 21 | 59 | 31 | 69 | 20,5 | 0,291       |
| G1/2 | 13 | 0446 13 21 | 27 | 27 | 51 | 23 | 21 | 67 | 34 | 69 | 20,5 | 0,335       |

maximum working pressure : 20 bar  
for model G 1/8, maximum panel thickness = 3 mm

## 6402 double female - screw fixing



sand-blasted body nickel plated-brass

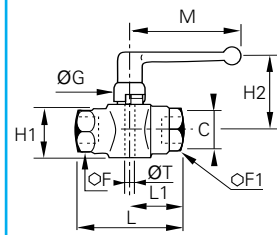

| C    | DN |            | F  | F1 | G  | H1 | H2 | L  | L1 | M   | T     | $\Delta$ kg |
|------|----|------------|----|----|----|----|----|----|----|-----|-------|-------------|
| G1/8 | 4  | 6402 04 10 | 14 | 14 | 18 | 18 | 30 | 44 | 25 | 48  | 4x70  | 0,126       |
| G1/4 | 7  | 6402 07 13 | 19 | 19 | 19 | 24 | 31 | 53 | 28 | 48  | 5x80  | 0,215       |
| G3/8 | 10 | 6402 10 17 | 24 | 24 | 20 | 30 | 45 | 59 | 31 | 69  | 5x80  | 0,319       |
| G1/2 | 13 | 6402 13 21 | 27 | 27 | 20 | 34 | 47 | 67 | 34 | 69  | 6x100 | 0,391       |
| G3/4 | 20 | 6402 20 27 | 32 | 38 | 27 | 44 | 52 | 80 | 39 | 108 | 8x125 | 0,823       |
| G1"  | 23 | 6402 23 34 | 41 | 46 | 27 | 53 | 56 | 94 | 47 | 108 | 8x125 | 1,246       |

maximum working pressure : 40 bar

## 6401 male and female



sand-blasted body nickel plated-brass

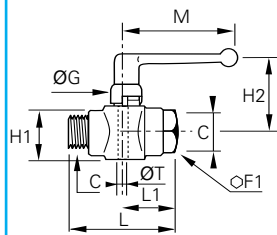

| C    | DN |            | F  | G  | H1 | H2 | L  | L1 | M  | T     | $\Delta$ kg |
|------|----|------------|----|----|----|----|----|----|----|-------|-------------|
| G1/8 | 4  | 6401 04 10 | 14 | 18 | 18 | 30 | 45 | 25 | 48 | 4x70  | 0,126       |
| G1/4 | 7  | 6401 07 13 | 19 | 19 | 24 | 31 | 52 | 28 | 48 | 5x80  | 0,215       |
| G3/8 | 10 | 6401 10 17 | 24 | 20 | 30 | 45 | 58 | 31 | 69 | 5x80  | 0,319       |
| G1/2 | 13 | 6401 13 21 | 27 | 20 | 34 | 47 | 67 | 34 | 69 | 6x100 | 0,391       |

maximum working pressure : 40 bar

## different methods of mounting

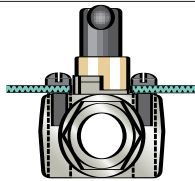

screw fixed mounting on a metal bulkhead with handle above the bulkhead

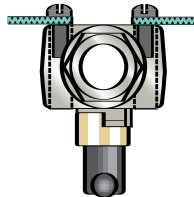

screw fixed mounting on a metal bulkhead with the complete valve below the bulkhead

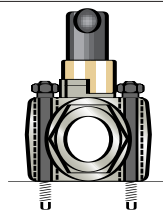

tapped fixing mounting onto a metal plate

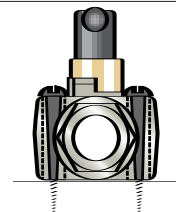

wood screw fixed mounting onto a wooden panel

dimensions between fixing hole centres

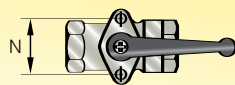

| C | G1/8 | G1/4 | G3/8 | G1/2 | G3/4 | G1" |
|---|------|------|------|------|------|-----|
| N | 25   | 31   | 31   | 34   | 43   | 51  |

Thread length (E) and BSP parallel male thread (E1) for 0446 - 6401 and 6402 ball valves

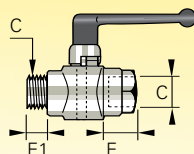

| C  | G1/8 | G1/4 | G3/8 | G1/2 | G3/4 | G1" |
|----|------|------|------|------|------|-----|
| E  | 8    | 12   | 12   | 15   | 16,5 | 19  |
| E1 | 7    | 9    | 11   | 12   |      |     |



# ball valves with right angled flow

## 0472 double female



sand blasted nickel-plated brass body

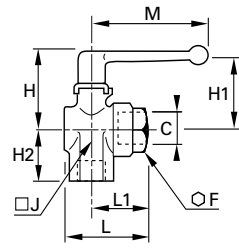

| C    | DN |            | F  | H  | H1 | H2 | J  | L  | L1 | M   | Δkg   |
|------|----|------------|----|----|----|----|----|----|----|-----|-------|
| G1/8 | 4  | 0472 04 10 | 14 | 35 | 29 | 18 | 14 | 34 | 25 | 48  | 0,095 |
| G1/8 | 6  | 0472 06 10 | 19 | 38 | 31 | 20 | 22 | 37 | 27 | 48  | 0,178 |
| G1/4 | 6  | 0472 06 13 | 19 | 38 | 31 | 24 | 22 | 38 | 28 | 48  | 0,177 |
| G3/8 | 9  | 0472 09 17 | 24 | 45 | 43 | 27 | 25 | 46 | 31 | 69  | 0,262 |
| G1/2 | 12 | 0472 12 21 | 27 | 47 | 44 | 33 | 29 | 49 | 34 | 69  | 0,315 |
| G3/4 | 18 | 0472 18 27 | 38 | 59 | 51 | 40 | 39 | 60 | 39 | 108 | 0,724 |
| G1"  | 23 | 0472 23 34 | 46 | 63 | 55 | 47 | 48 | 72 | 47 | 108 | 1,080 |

maximum working pressure : 20 bar

## 0471 male and female



sand blasted nickel-plated brass body

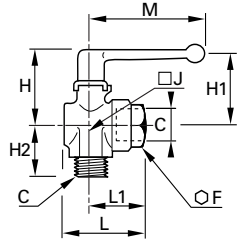

| C    | DN |            | F  | H  | H1 | H2 | J  | L  | L1 | M   | Δkg   |
|------|----|------------|----|----|----|----|----|----|----|-----|-------|
| G1/8 | 4  | 0471 04 10 | 14 | 35 | 29 | 19 | 14 | 34 | 25 | 48  | 0,095 |
| G1/8 | 6  | 0471 06 10 | 19 | 38 | 31 | 22 | 22 | 37 | 27 | 48  | 0,168 |
| G1/4 | 6  | 0471 06 13 | 19 | 38 | 31 | 25 | 22 | 38 | 28 | 48  | 0,171 |
| G3/8 | 9  | 0471 09 17 | 24 | 45 | 43 | 28 | 25 | 46 | 31 | 69  | 0,259 |
| G1/2 | 12 | 0471 12 21 | 27 | 47 | 44 | 32 | 29 | 49 | 34 | 69  | 0,308 |
| G3/4 | 18 | 0471 18 27 | 38 | 59 | 51 | 37 | 39 | 60 | 39 | 108 | 0,718 |
| G1"  | 23 | 0471 23 34 | 46 | 63 | 55 | 44 | 48 | 72 | 47 | 108 | 1,020 |

maximum working pressure : 20 bar

Thread length (E) and **BSP parallel** male thread (E1) for 0472 and 0471

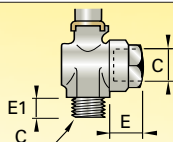

| C  | G1/8 | G1/4 | G3/8 | G1/2 | G3/4 | G1" |
|----|------|------|------|------|------|-----|
| E  | 8    | 12   | 12   | 15   | 16,5 | 19  |
| E1 | 7    | 9    | 11   | 12   | 12   | 15  |

# standard 3 way ball valves

## 0482 female right angled porting

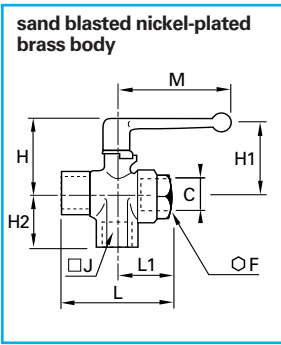

| C    | DN |            | F  | H  | H1 | H2 | J  | L  | L1 | M   | kg    |
|------|----|------------|----|----|----|----|----|----|----|-----|-------|
| G1/8 | 4  | 0482 04 10 | 14 | 35 | 29 | 18 | 14 | 44 | 25 | 48  | 0,110 |
| G1/4 | 6  | 0482 06 13 | 19 | 38 | 31 | 24 | 22 | 53 | 28 | 48  | 0,187 |
| G3/8 | 9  | 0482 09 17 | 24 | 45 | 43 | 27 | 25 | 59 | 31 | 69  | 0,285 |
| G1/2 | 12 | 0482 12 21 | 27 | 47 | 44 | 33 | 29 | 67 | 34 | 69  | 0,351 |
| G3/4 | 18 | 0482 18 27 | 38 | 59 | 51 | 40 | 39 | 80 | 39 | 108 | 0,386 |
| G1"  | 23 | 0482 23 34 | 46 | 63 | 55 | 47 | 48 | 94 | 47 | 108 | 1,172 |

maximum working pressure : 20 bar



## 0483 female right angled porting without closed position

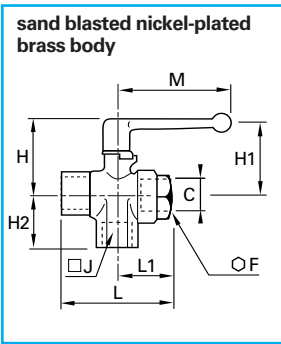

| C    | DN |            | F  | H  | H1 | H2 | J  | L  | L1 | M   | kg    |
|------|----|------------|----|----|----|----|----|----|----|-----|-------|
| G1/8 | 4  | 0483 04 10 | 14 | 35 | 29 | 18 | 14 | 44 | 25 | 48  | 0,102 |
| G1/4 | 6  | 0483 06 13 | 19 | 38 | 31 | 24 | 22 | 53 | 28 | 48  | 0,187 |
| G3/8 | 9  | 0483 09 17 | 24 | 45 | 43 | 27 | 25 | 59 | 31 | 69  | 0,283 |
| G1/2 | 12 | 0483 12 21 | 27 | 47 | 44 | 33 | 29 | 67 | 34 | 69  | 0,352 |
| G3/4 | 18 | 0483 18 27 | 38 | 59 | 51 | 40 | 39 | 80 | 39 | 108 | 0,712 |
| G1"  | 23 | 0483 23 34 | 46 | 63 | 55 | 47 | 48 | 94 | 47 | 108 | 1,090 |

maximum working pressure : 20 bar

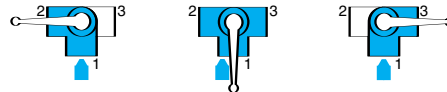

## 0448 panel mountable female right angled porting

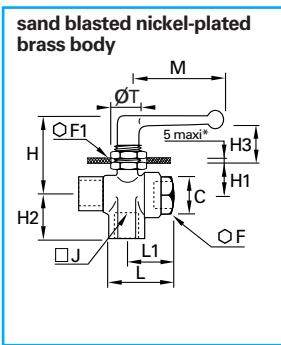

| C    | DN |            | F  | F1 | H  | H1 | H2 | H3 | J  | L  | L1 | M  | T    | kg    |
|------|----|------------|----|----|----|----|----|----|----|----|----|----|------|-------|
| G1/8 | 4  | 0448 04 10 | 14 | 22 | 37 | 14 | 18 | 12 | 14 | 44 | 25 | 48 | 16,5 | 0,122 |
| G1/4 | 6  | 0448 06 13 | 19 | 24 | 45 | 19 | 24 | 14 | 22 | 53 | 28 | 48 | 20,5 | 0,224 |
| G3/8 | 9  | 0448 09 17 | 24 | 27 | 50 | 21 | 27 | 21 | 25 | 59 | 31 | 69 | 20,5 | 0,324 |
| G1/2 | 12 | 0448 12 21 | 27 | 27 | 51 | 23 | 33 | 21 | 29 | 67 | 34 | 69 | 20,5 | 0,398 |

maximum working pressure : 20 bar

\*G1/8 version : maximum panel thickness = 3 mm

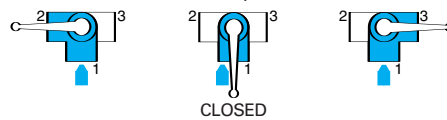

## 0452 panel mountable female equal plane porting - 3 port 2way

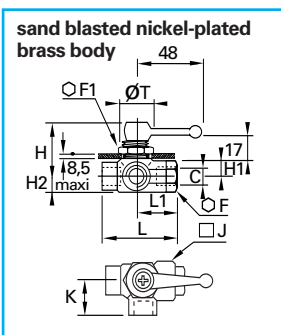

| C    | DN |            | F  | F1 | H  | H1 | H2 | J  | K  | L  | T  | kg |       |
|------|----|------------|----|----|----|----|----|----|----|----|----|----|-------|
| G1/8 | 4  | 0452 04 10 | 14 | 22 | 39 | 10 | 8  | 16 | 18 | 44 | 25 | 19 | 0,316 |
| G1/4 | 6  | 0452 06 13 | 19 | 24 | 40 | 11 | 11 | 23 | 24 | 53 | 28 | 20 | 0,298 |

maximum working pressure : 20 bar

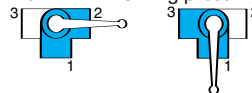

length of internal BSPP thread (E)  
for 0482 – 0448 – 0452 and 0483

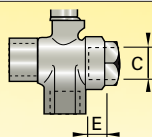

| C | G1/8 | G1/4 | G3/8 | G1/2 | G3/4 | G1" |
|---|------|------|------|------|------|-----|
| E | 8    | 12   | 12   | 15   | 16,5 | 19  |

# light series ball valves

Light series ball valves allow the passage of many fluids and are suited to high pressures and temperatures. Their constituent materials are the same as for the standard range.

## technical specifications

- maximum working pressure : 12 bar
- working temperature : -20° to +80°C

### 0492 double female

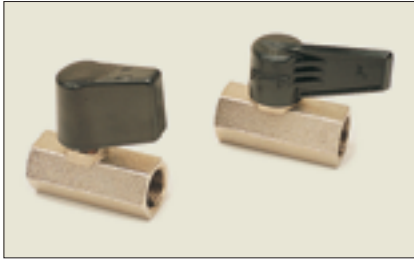

nickel-plated brass body  
polymer HR handle

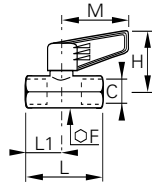

| C    | DN |                | F  | H  | L    | L1 | M  | Δkg   |
|------|----|----------------|----|----|------|----|----|-------|
| G1/4 | 4  | 0492 04 13     | 17 | 34 | 39,5 | 17 | 35 | 0,071 |
| G1/4 | 4  | 0492 04 13 64* | 17 | 36 | 39,5 | 17 | 25 | 0,069 |
| G3/8 | 7  | 0492 07 17     | 22 | 38 | 45   | 20 | 43 | 0,121 |
| G1/2 | 10 | 0492 10 21     | 24 | 44 | 54   | 25 | 50 | 0,155 |
| G3/4 | 13 | 0492 13 27     | 30 | 46 | 62   | 28 | 50 | 0,237 |

\* Zamac short handle

### 0491 male and female



nickel-plated brass body  
polymer HR handle

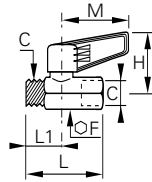

| C    | DN |                | F  | H  | L    | L1 | M  | Δkg   |
|------|----|----------------|----|----|------|----|----|-------|
| G1/4 | 4  | 0491 04 13     | 17 | 34 | 39,5 | 17 | 35 | 0,071 |
| G1/4 | 4  | 0491 04 13 64* | 17 | 36 | 39,5 | 17 | 25 | 0,069 |
| G3/8 | 7  | 0491 07 17     | 22 | 38 | 45   | 20 | 43 | 0,118 |
| G1/2 | 10 | 0491 10 21     | 24 | 44 | 53   | 24 | 50 | 0,154 |
| G3/4 | 13 | 0491 13 27     | 30 | 46 | 59   | 25 | 50 | 0,228 |

\* Zamac short handle

### 0490 double male



nickel-plated brass body  
polymer HR handle

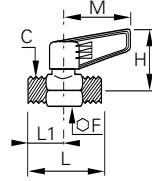

| C    | DN |            | F  | H  | L  | L1 | M  | Δkg   |
|------|----|------------|----|----|----|----|----|-------|
| G1/4 | 4  | 0490 04 13 | 17 | 34 | 39 | 17 | 35 | 0,070 |
| G3/8 | 7  | 0490 07 17 | 22 | 38 | 44 | 20 | 43 | 0,108 |
| G1/2 | 10 | 0490 10 21 | 24 | 44 | 53 | 24 | 50 | 0,152 |
| G3/4 | 13 | 0490 13 27 | 30 | 46 | 59 | 25 | 50 | 0,218 |

### 0494 double female with two vent plugs



nickel-plated brass body  
polymer HR handle

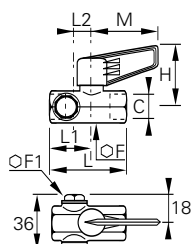

| C    | DN |            | F  | F1 | H  | L  | L1 | L2 | M  | Δkg   |
|------|----|------------|----|----|----|----|----|----|----|-------|
| G3/8 | 7  | 0494 07 17 | 22 | 16 | 38 | 60 | 20 | 15 | 43 | 0,180 |

Light series ball valves are also available with a square stem and without handle . Please refer to page R12.

**BSPP thread length E and E1**  
for valves references  
0492 - 0491 - 0490 and 0494

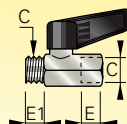

| C  | G1/4 | G3/8 | G1/2 | G3/4 |
|----|------|------|------|------|
| E  | 9    | 11   | 12   | 14   |
| E1 | 7    | 8    | 10   | 12   |

# light series ball valves with square stem

## 0497 double female with square stem



sand blasted brass body

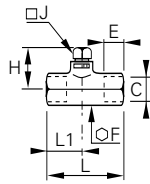

| C    | DN |            | E  | F  | H  | J  | L  | L1 | kg    |
|------|----|------------|----|----|----|----|----|----|-------|
| G1/4 | 4  | 0497 04 13 | 9  | 17 | 25 | 7  | 39 | 17 | 0,067 |
| G3/8 | 7  | 0497 07 17 | 11 | 22 | 26 | 7  | 45 | 20 | 0,114 |
| G1/2 | 10 | 0497 10 21 | 12 | 24 | 29 | 10 | 54 | 25 | 0,144 |
| G3/4 | 13 | 0497 13 27 | 14 | 30 | 30 | 10 | 62 | 28 | 0,227 |

## 0496 male and female with square stem



sand blasted brass body

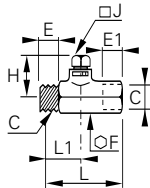

| C    | DN |            | E  | E1 | F  | H  | J  | L  | L1 | kg    |
|------|----|------------|----|----|----|----|----|----|----|-------|
| G1/4 | 4  | 0496 04 13 | 9  | 7  | 17 | 25 | 7  | 39 | 17 | 0,065 |
| G3/8 | 7  | 0496 07 17 | 11 | 8  | 22 | 26 | 7  | 45 | 20 | 0,099 |
| G1/2 | 10 | 0496 10 21 | 12 | 10 | 24 | 29 | 10 | 53 | 24 | 0,144 |
| G3/4 | 13 | 0496 13 27 | 14 | 12 | 30 | 30 | 10 | 59 | 25 | 0,222 |

# lenticular shut-off valves

The internal component used to shut-off the flow of Legris **lenticular shut-off valves** is a segment of a sphere. Therefore, these valves are usable with abrasive fluids (including solid particles). Lenticular valves can only accommodate fluid flow in one direction. The fluid direction is shown by an arrow on the valve body. The main advantages of this range are **low operating torque**, even with high fluid pressure, due to small friction coefficient of lenticule on the ball seal, **perfect sealing**, **small overall dimensions** and long life.

### technical specifications :

- maximum working pressure : 16 bar
- working temperature : - 20° to + 80°C
- compatible fluids : compressed air, industrial gas, water, cutting oil, mineral oil, fuel, inert gases, solid particles...
- lenticule : stainless steel
- seals : nitrile

## 4602 double female



sand blasted nickel-plated brass body black epoxy coated zamac handle

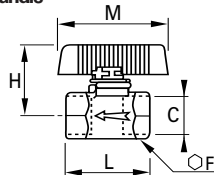

| C    |            | E  | F  | H  | L  | M  | kg    |
|------|------------|----|----|----|----|----|-------|
| G1/4 | 4602 06 13 | 9  | 17 | 35 | 34 | 54 | 0,101 |
| G3/8 | 4602 07 17 | 11 | 22 | 35 | 39 | 54 | 0,137 |
| G1/2 | 4602 10 21 | 12 | 24 | 37 | 42 | 54 | 0,142 |
| G3/4 | 4602 13 27 | 14 | 30 | 40 | 49 | 54 | 0,209 |
| G1"  | 4602 18 34 | 15 | 41 | 46 | 55 | 54 | 0,408 |



# in-line ball valves, fluoropolymer series

This range of ball valves is suitable for many industrial applications, when the fluid carried and working temperatures require PTFE seals. The range is available in two versions.

## H.R. range

- excellent resistance to high pressure and temperature constraints
- full flow fluid passage
- silicone free, in order to meet specific application requirements – e.g. automotive process industry.
- both high quality and good value.

## Specifications

**Fluids** : compressed air, gas, water, water steam, oil and all fluids suitable with constituent materials.

**Working temperature** : -20° to + 130°C

**Working pressure** : 25 to 30 bar, depending on the model

### Materials :

- body: sand blasted nickel-plated brass
- ball: nickel-plated chromed brass
- handle: blue plastic coated steel
- stem : nickel-plated brass
- ball seals: PTFE
- stem seals: PTFE

## 4902 double female

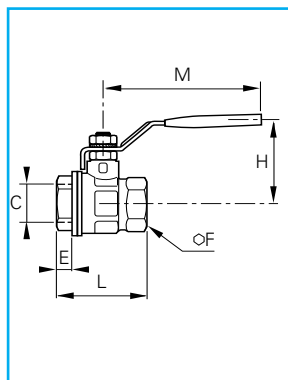

| C                  | DN  | PN |             | E    | F   | H   | L    | M   | kg    |
|--------------------|-----|----|-------------|------|-----|-----|------|-----|-------|
| G1/4               | 10  | 30 | 4902 10 13  | 11   | 20  | 43  | 51,5 | 98  | 0,140 |
| G3/8               | 10  | 30 | 4902 10 17  | 11,4 | 20  | 43  | 51,5 | 98  | 0,130 |
| G1/2               | 15  | 30 | 4902 15 21  | 13,5 | 25  | 47  | 55   | 98  | 0,200 |
| G3/4               | 20  | 30 | 4902 20 27  | 12,5 | 31  | 58  | 57,5 | 122 | 0,320 |
| G1"                | 25  | 30 | 4902 25 34  | 15   | 38  | 60  | 69,5 | 122 | 0,490 |
| G1" <sup>1/4</sup> | 32  | 25 | 4902 32 42* | 17   | 48  | 77  | 81,5 | 153 | 0,900 |
| G1" <sup>1/2</sup> | 40  | 25 | 4902 40 49* | 18   | 54  | 83  | 95   | 153 | 1,350 |
| G2"                | 50  | 25 | 4902 50 48* | 22   | 66  | 95  | 113  | 162 | 1,800 |
| G2" <sup>1/2</sup> | 65  | 30 | 4902 65 47* | 22   | 85  | 132 | 136  | 255 | 4,300 |
| G3"                | 80  | 30 | 4902 80 46* | 25   | 99  | 140 | 157  | 255 | 5,840 |
| G4"                | 100 | 30 | 4902 01 45* | 29   | 125 | 154 | 191  | 255 | 9,040 |

\*models with CE marking

# in-line ball valves, fluoropolymer series

## Economy range

- **economical** solution, for many industrial applications.
- **full flow** fluid passage
- each model is available in 2 designs:
  - with a **standard handle**
  - with a **butterfly handle**, to overcome the constraints of reduced spaces.

## Specifications

**Fluids** : compressed air, inert gases, water and all fluids suitable with constituent materials.

**Working temperature**: -20° to + 90°C

**Working pressure**: 16 to 25 bar, depending on the model

### Materials :

- body: sand blasted nickel-plated brass
- ball: nickel-plated chromed brass
- handle: black plastic coated steel
- stem : nickel-plated brass
- ball seals: PTFE
- stem seals: NBR

## 4905 double female with standard handle, BSP parallel

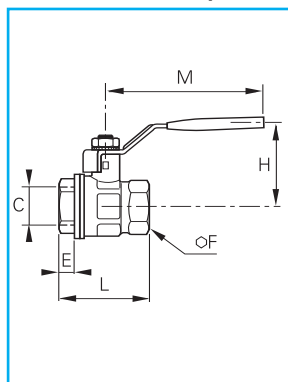

| C       | DN | PN |            | E  | F  | H    | L    | M   | ΔkgΔ  |
|---------|----|----|------------|----|----|------|------|-----|-------|
| G1/4    | 10 | 25 | 4905 00 13 | 10 | 21 | 37   | 44   | 70  | 0,145 |
| G3/8    | 10 | 25 | 4905 00 17 | 10 | 21 | 37   | 44   | 70  | 0,130 |
| G1/2    | 15 | 25 | 4905 00 21 | 12 | 25 | 40   | 51   | 85  | 0,180 |
| G3/4    | 20 | 25 | 4905 00 27 | 13 | 31 | 47   | 57   | 104 | 0,270 |
| G1"     | 25 | 25 | 4905 00 34 | 15 | 38 | 51   | 67   | 104 | 0,420 |
| G1 1/4" | 32 | 16 | 4905 00 42 | 15 | 47 | 61   | 80   | 122 | 0,670 |
| G1 1/2" | 40 | 16 | 4905 00 49 | 16 | 54 | 75,5 | 90,5 | 152 | 0,960 |
| G2"     | 50 | 16 | 4905 00 48 | 16 | 67 | 79   | 101  | 136 | 1,380 |

## 4906 double female with butterfly handle, BSP parallel

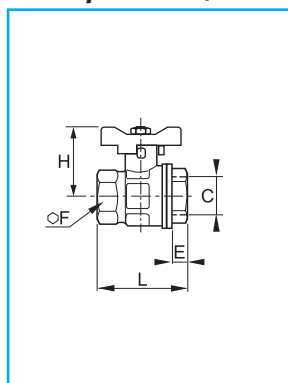

| C     | DN | PN |            | E  | F  | H    | L  | ΔkgΔ  |
|-------|----|----|------------|----|----|------|----|-------|
| G1/4  | 10 | 25 | 4906 00 13 | 10 | 21 | 35,5 | 44 | 0,125 |
| G 3/8 | 10 | 25 | 4906 00 17 | 10 | 21 | 35,5 | 44 | 0,110 |
| G 1/2 | 15 | 25 | 4906 00 21 | 12 | 25 | 38   | 51 | 0,165 |
| G 3/4 | 20 | 25 | 4906 00 27 | 13 | 31 | 43   | 57 | 0,235 |
| G 1"  | 25 | 25 | 4906 00 34 | 15 | 38 | 50   | 67 | 0,400 |

Dimensions given are provided for guidance only.

# in-line ball valves, fluoropolymer series

## 4900 double male with standard handle, BSP parallel

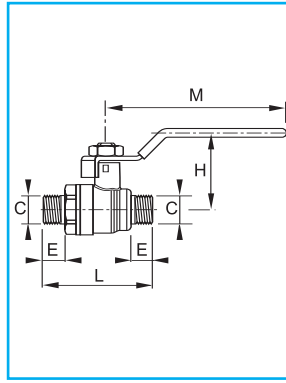

| C        | DN | PN |                            | E  | H    | L     | M   | $\Delta$ kg $\Delta$ |
|----------|----|----|----------------------------|----|------|-------|-----|----------------------|
| G 1/4    | 10 | 25 | <a href="#">4900 00 13</a> | 9  | 37   | 51    | 70  | 0,150                |
| G 3/8    | 10 | 25 | <a href="#">4900 00 17</a> | 10 | 37   | 51    | 70  | 0,150                |
| G 1/2    | 15 | 25 | <a href="#">4900 00 21</a> | 12 | 40   | 60    | 85  | 0,200                |
| G 3/4    | 20 | 25 | <a href="#">4900 00 27</a> | 13 | 47   | 67    | 104 | 0,300                |
| G 1"     | 25 | 25 | <a href="#">4900 00 34</a> | 15 | 51   | 77,5  | 104 | 0,470                |
| G 1 1/4" | 32 | 16 | <a href="#">4900 00 42</a> | 15 | 61   | 90    | 122 | 0,785                |
| G 1 1/2" | 40 | 16 | <a href="#">4900 00 49</a> | 16 | 75,5 | 102,5 | 152 | 1,080                |
| G 2"     | 50 | 16 | <a href="#">4900 00 48</a> | 16 | 79   | 114   | 136 | 1,500                |

## 4903 double male with butterfly handle, BSP parallel

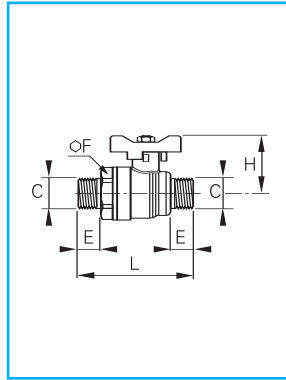

| C     | DN | PN |                            | E  | F  | H    | L  | $\Delta$ kg $\Delta$ |
|-------|----|----|----------------------------|----|----|------|----|----------------------|
| G 1/4 | 10 | 25 | <a href="#">4903 00 13</a> | 9  | 21 | 35,5 | 44 | 0,130                |
| G 3/8 | 10 | 25 | <a href="#">4903 00 17</a> | 10 | 21 | 35,5 | 44 | 0,130                |
| G 1/2 | 15 | 25 | <a href="#">4903 00 21</a> | 12 | 25 | 38   | 51 | 0,185                |
| G 3/4 | 20 | 25 | <a href="#">4903 00 27</a> | 13 | 31 | 43   | 57 | 0,265                |
| G 1"  | 25 | 25 | <a href="#">4903 00 34</a> | 15 | 38 | 50   | 67 | 0,450                |

## 4901 male - female with standard handle, BSP parallel

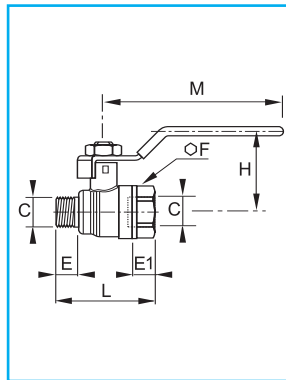

| C        | DN | PN |                            | E1 | E  | F  | H    | L    | M   | $\Delta$ kg $\Delta$ |
|----------|----|----|----------------------------|----|----|----|------|------|-----|----------------------|
| G 1/4    | 10 | 25 | <a href="#">4901 00 13</a> | 9  | 10 | 21 | 37   | 44   | 70  | 0,150                |
| G 3/8    | 10 | 25 | <a href="#">4901 00 17</a> | 10 | 10 | 21 | 37   | 44   | 70  | 0,140                |
| G 1/2    | 15 | 25 | <a href="#">4901 00 21</a> | 12 | 12 | 25 | 40   | 51   | 85  | 0,175                |
| G 3/4    | 20 | 25 | <a href="#">4901 00 27</a> | 13 | 13 | 31 | 47   | 57   | 104 | 0,260                |
| G 1"     | 25 | 25 | <a href="#">4901 00 34</a> | 15 | 15 | 38 | 51   | 67   | 104 | 0,415                |
| G 1 1/4" | 32 | 16 | <a href="#">4901 00 42</a> | 15 | 15 | 47 | 61   | 80   | 122 | 0,755                |
| G 1 1/2" | 40 | 16 | <a href="#">4901 00 49</a> | 16 | 16 | 54 | 75,5 | 90,5 | 152 | 0,940                |
| G 2"     | 50 | 16 | <a href="#">4901 00 48</a> | 16 | 16 | 67 | 79   | 101  | 136 | 1,270                |

## 4904 male - female with butterfly handle, BSP parallel

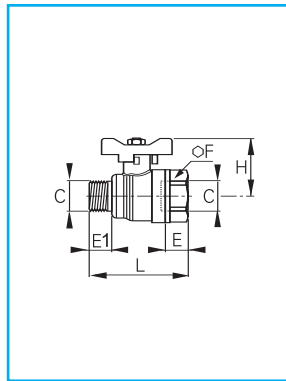

| C     | DN | PN |                            | E1 | E  | F  | H    | L  | $\Delta$ kg $\Delta$ |
|-------|----|----|----------------------------|----|----|----|------|----|----------------------|
| G 1/4 | 10 | 25 | <a href="#">4904 00 13</a> | 9  | 10 | 21 | 35,5 | 44 | 0,130                |
| G 3/8 | 10 | 25 | <a href="#">4904 00 17</a> | 10 | 10 | 21 | 35,5 | 44 | 0,120                |
| G 1/2 | 15 | 25 | <a href="#">4904 00 21</a> | 12 | 12 | 25 | 38   | 51 | 0,160                |
| G 3/4 | 20 | 25 | <a href="#">4904 00 27</a> | 13 | 13 | 31 | 43   | 57 | 0,225                |
| G 1"  | 25 | 25 | <a href="#">4904 00 34</a> | 15 | 15 | 38 | 50   | 67 | 0,395                |

Dimensions given are provided for guidance only.

# lockable ball valves



**Legris lockable ball valves** have been developed in order to prevent potentially dangerous consequences caused by unintended operation. Lockable in different positions, this range meets international **safety** requirements, such as ISO 4414.

Lockable ball valves feature a plate fixed to the valve body and a plate attached to the valve stem. When the plates are padlocked together, the valve handle cannot be moved.

The valves are lockable :

- in both **open and closed position**, by one padlock : models **0432** and **0439**
- **only in the closed position** by up to three padlocks : models **0437** and **0438**.

## 0432 in-line double female



sand blasted nickel plated brass

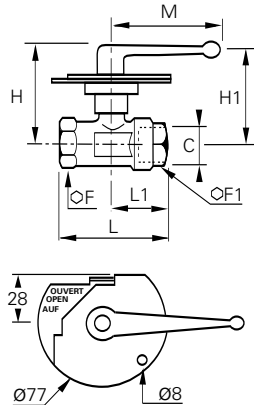

both fixed and moveable plates are zinc plated steel

| C    | DN |            | F  | F1 | H  | H1 | L  | L1 | M   | kg    |
|------|----|------------|----|----|----|----|----|----|-----|-------|
| G1/8 | 4  | 0432 04 10 | 19 | 19 | 59 | 54 | 51 | 27 | 69  | 0,413 |
| G1/4 | 7  | 0432 07 13 | 19 | 19 | 59 | 54 | 59 | 28 | 69  | 0,397 |
| G3/8 | 10 | 0432 10 17 | 24 | 24 | 60 | 55 | 59 | 31 | 69  | 0,463 |
| G1/2 | 13 | 0432 13 21 | 27 | 27 | 62 | 57 | 67 | 34 | 69  | 0,515 |
| G3/4 | 20 | 0432 20 27 | 32 | 38 | 66 | 56 | 80 | 39 | 108 | 0,846 |
| G1"  | 23 | 0432 23 34 | 41 | 46 | 70 | 59 | 94 | 47 | 108 | 1,174 |

maximum service pressure : 40 bar  
handle is non-removeable

## 0438 female 3 port 2way lockable ball valve sand blasted nickel-plated body



nickel plated brass

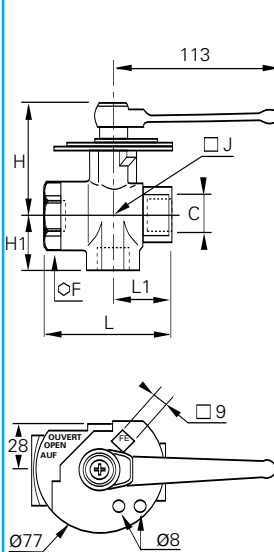

fixed plate : zinc plated steel  
moveable plate : steel, grey epoxy coated

| C    | DN |            | F  | H  | H1 | J  | L  | L1 | kg    |
|------|----|------------|----|----|----|----|----|----|-------|
| G3/8 | 9  | 0438 09 17 | 38 | 76 | 34 | 39 | 73 | 35 | 0,905 |
| G1/2 | 12 | 0438 12 21 | 38 | 76 | 37 | 39 | 78 | 38 | 0,896 |
| G3/4 | 18 | 0438 18 27 | 38 | 76 | 40 | 39 | 80 | 40 | 0,845 |
| G1"  | 23 | 0438 23 34 | 46 | 80 | 47 | 48 | 94 | 47 | 1,268 |

maximum working pressure : 20 bar

These valves are lockable in the closed position only.  
Right angle ported ball allows flow :

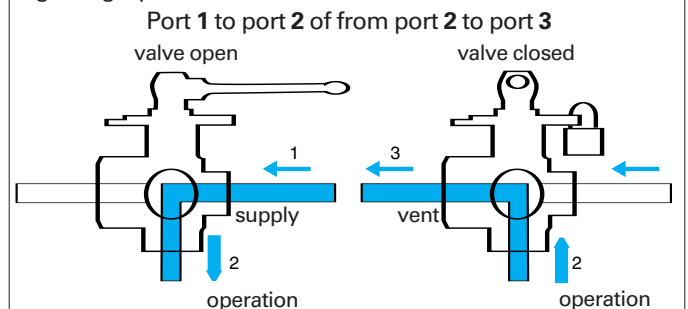

**removable handle** : where the handle is obstructed in its movement it can be refitted opposite the original position.



# lockable ball valves

## 0437 in-line double female vented lockable ball valve



sand blasted nickel-plated body

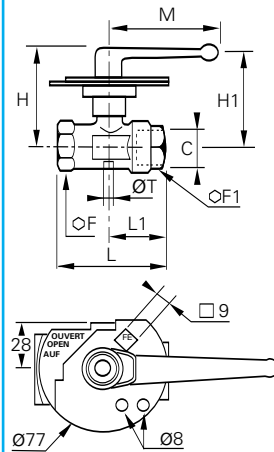

locking plates are zinc plated steel

| C    | DN |            | F  | F1 | H    | L    | L1   | M     | T   | kg    |
|------|----|------------|----|----|------|------|------|-------|-----|-------|
| G1/4 | 7  | 0437 07 13 | 24 | 24 | 60   | 59   | 32   | 69,5  | 2   | 0,397 |
| G3/8 | 10 | 0437 10 17 | 24 | 24 | 60   | 60   | 32   | 69,5  | 2   | 0,463 |
| G1/2 | 13 | 0437 13 21 | 27 | 27 | 60   | 67,5 | 34,5 | 69,5  | 2   | 0,515 |
| G3/4 | 18 | 0437 18 27 | 32 | 38 | 69,5 | 80   | 39,5 | 108,5 | 2,5 | 0,846 |
| G1"  | 23 | 0437 23 34 | 41 | 46 | 73   | 94,5 | 47,5 | 108,5 | 3   | 1,174 |

maximum working pressure : 40 bar  
handle is non-removable

## 0439 double female with vent

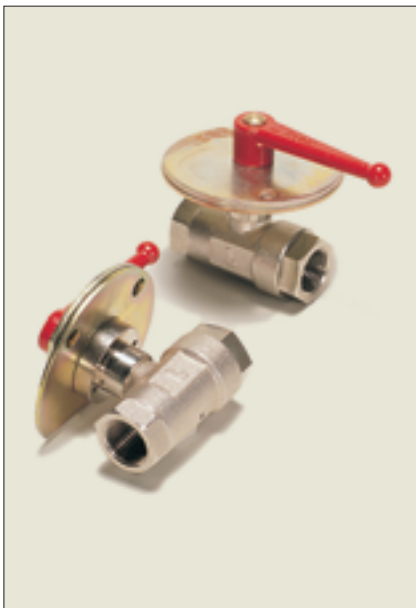

sand blasted nickel plated brass

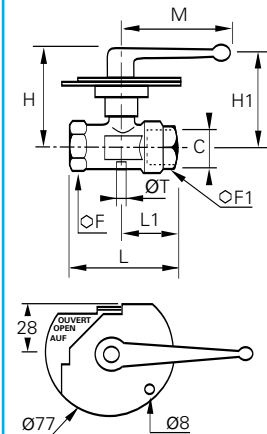

both fixed and moveable plates are zinc plated steel

| C    | DN |            | F  | F1 | H  | H1 | L  | L1 | M   | T   | kg    |
|------|----|------------|----|----|----|----|----|----|-----|-----|-------|
| G1/8 | 4  | 0439 04 10 | 19 | 19 | 59 | 54 | 51 | 27 | 69  | 2   | 0,420 |
| G1/4 | 7  | 0439 07 13 | 24 | 24 | 60 | 55 | 59 | 31 | 69  | 2   | 0,480 |
| G3/8 | 10 | 0439 10 17 | 24 | 24 | 60 | 55 | 59 | 31 | 69  | 2   | 0,459 |
| G1/2 | 13 | 0439 13 21 | 27 | 27 | 62 | 57 | 67 | 34 | 69  | 2   | 0,511 |
| G3/4 | 18 | 0439 18 27 | 32 | 38 | 66 | 56 | 80 | 39 | 108 | 2,5 | 0,834 |
| G1"  | 23 | 0439 23 34 | 41 | 46 | 70 | 59 | 94 | 47 | 108 | 3   | 1,166 |

maximum service pressure : 40 bar  
handle is non-removable

Length of BSPP threads (E) for 0432  
– 0439 – 0437 and 0438

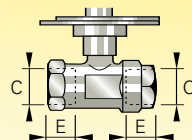

| C | G1/8 | G1/4 | G3/8 | G1/2 | G3/4 | G1" |
|---|------|------|------|------|------|-----|
| E | 8    | 12   | 12   | 15   | 16,5 | 19  |

# standard, in-line vented ball valves



In certain situations, there is a requirement for stopping fluid circulation and venting the circuit. Therefore Legris offers 2 types of **in-line vented ball valves** :

- **with threaded exhaust**, to allow discharge of downstream media.
- **with pin-hole vent**, for applications with no special discharge requirement

Fluid flow direction is indicated by an arrow on the valve body.

with threaded exhaust = collection of purged media

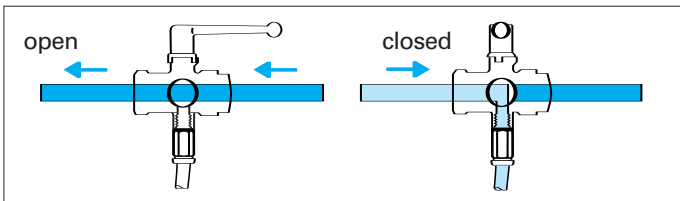

with silencer noiseless discharge to atmosphere

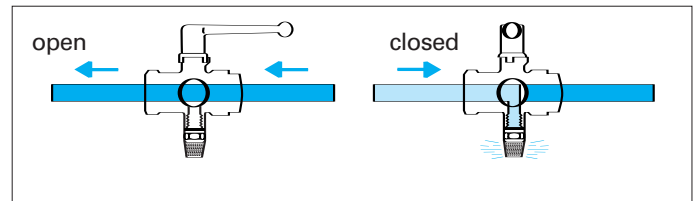

## 0489 double female BSPP valve with threaded exhaust



sand blasted nickel-plated body

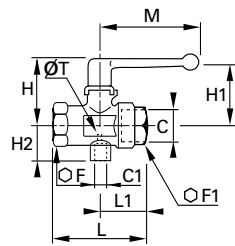

| C    | DN |                            | C1     | F  | F1 | H  | H1 | H2 | L  | L1 | M   | T   | kg    |
|------|----|----------------------------|--------|----|----|----|----|----|----|----|-----|-----|-------|
| G1/4 | 7  | <a href="#">0489 07 13</a> | M5x0,8 | 24 | 24 | 46 | 43 | 17 | 59 | 31 | 69  | 2   | 0,269 |
| G3/8 | 10 | <a href="#">0489 10 17</a> | M5x0,8 | 24 | 24 | 46 | 43 | 17 | 59 | 31 | 69  | 2   | 0,294 |
| G1/2 | 13 | <a href="#">0489 13 21</a> | G1/8   | 27 | 27 | 47 | 44 | 24 | 67 | 34 | 69  | 2   | 0,312 |
| G3/4 | 18 | <a href="#">0489 18 27</a> | G1/4   | 32 | 38 | 63 | 54 | 33 | 80 | 39 | 108 | 2,5 | 0,754 |
| G1"  | 23 | <a href="#">0489 23 34</a> | G1/4   | 41 | 46 | 67 | 57 | 37 | 94 | 47 | 108 | 3   | 1,088 |

maximum working pressure : 40 bar

## 0449 double female BSPP valve, panel mountable with threaded exhaust



sand blasted nickel-plated body

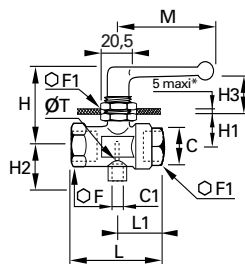

| C    | DN |                            | C1     | F  | F1 | H  | H1 | H2 | H3 | L  | L1 | M  | T   | kg    |
|------|----|----------------------------|--------|----|----|----|----|----|----|----|----|----|-----|-------|
| G1/4 | 7  | <a href="#">0449 07 13</a> | M5x0,8 | 24 | 27 | 50 | 20 | 17 | 21 | 59 | 31 | 69 | 2,5 | 0,316 |
| G3/8 | 10 | <a href="#">0449 10 17</a> | M5x0,8 | 24 | 27 | 50 | 20 | 17 | 21 | 59 | 31 | 69 | 2,5 | 0,298 |
| G1/2 | 13 | <a href="#">0449 13 21</a> | G1/8   | 27 | 27 | 52 | 23 | 24 | 21 | 67 | 34 | 69 | 4   | 0,354 |

maximum working pressure : 20 bar

## 0469 double female vented BSPP valve



sand blasted nickel-plated body

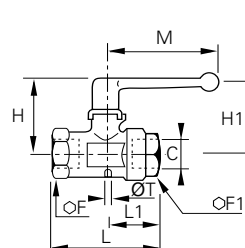

| C    | DN |                            | F  | F1 | H  | H1 | L  | L1 | M   | T   | kg    |
|------|----|----------------------------|----|----|----|----|----|----|-----|-----|-------|
| G1/8 | 4  | <a href="#">0469 04 10</a> | -  | 14 | 35 | 29 | 44 | 25 | 48  | 1,5 | 0,100 |
| G1/4 | 7  | <a href="#">0469 07 13</a> | 24 | 24 | 46 | 43 | 59 | 31 | 70  | 2   | 0,258 |
| G3/8 | 10 | <a href="#">0469 10 17</a> | 24 | 24 | 46 | 43 | 59 | 31 | 70  | 2   | 0,246 |
| G1/2 | 13 | <a href="#">0469 13 21</a> | 27 | 27 | 47 | 44 | 67 | 34 | 70  | 2   | 0,292 |
| G3/4 | 18 | <a href="#">0469 18 27</a> | 32 | 38 | 63 | 54 | 80 | 39 | 108 | 2,5 | 0,700 |
| G1"  | 23 | <a href="#">0469 23 34</a> | 41 | 46 | 67 | 57 | 94 | 47 | 108 | 3   | 1,020 |

maximum working pressure : 40 bar

# standard vented ball valves with right angled flow

## 0462 double female with vent



sand blasted nickel-plated brass body + red handle

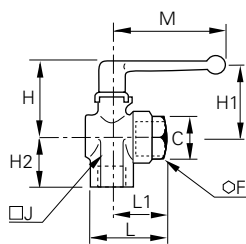

| C    | DN |            | F  | H  | H1 | H2 | J  | L  | L1 | M   | kg    |
|------|----|------------|----|----|----|----|----|----|----|-----|-------|
| G1/8 | 6  | 0462 06 10 | 19 | 38 | 31 | 20 | 22 | 37 | 27 | 48  | 0,175 |
| G1/4 | 6  | 0462 06 13 | 19 | 38 | 31 | 24 | 22 | 38 | 28 | 48  | 0,175 |
| G3/8 | 9  | 0462 09 17 | 24 | 45 | 43 | 27 | 25 | 46 | 31 | 69  | 0,265 |
| G1/2 | 12 | 0462 12 21 | 27 | 47 | 44 | 33 | 29 | 49 | 34 | 69  | 0,310 |
| G3/4 | 18 | 0462 18 27 | 38 | 59 | 51 | 40 | 39 | 60 | 39 | 108 | 0,730 |
| G1"  | 23 | 0462 23 34 | 46 | 63 | 55 | 47 | 48 | 72 | 47 | 108 | 1,054 |

maximum working pressure : 20 bar

## 0461 male and female with vent



sand blasted nickel-plated brass body + red handle

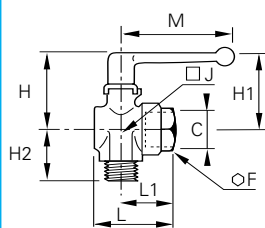

| C    | DN |            | F  | H  | H1 | H2 | J  | L  | L1 | M   | kg    |
|------|----|------------|----|----|----|----|----|----|----|-----|-------|
| G1/8 | 6  | 0461 06 10 | 19 | 38 | 31 | 22 | 22 | 37 | 27 | 48  | 0,169 |
| G1/4 | 6  | 0461 06 13 | 19 | 38 | 31 | 25 | 22 | 38 | 28 | 48  | 0,169 |
| G3/8 | 9  | 0461 09 17 | 24 | 45 | 43 | 28 | 25 | 46 | 31 | 69  | 0,258 |
| G1/2 | 12 | 0461 12 21 | 27 | 47 | 44 | 32 | 29 | 49 | 34 | 69  | 0,312 |
| G3/4 | 18 | 0461 18 27 | 38 | 59 | 51 | 37 | 39 | 60 | 39 | 108 | 0,704 |

maximum working pressure : 20 bar

Thread length (E) and **BSP parallel** male thread (E1) for 0462 and 0461

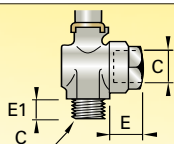

| C  | G1/8 | G1/4 | G3/8 | G1/2 | G3/4 | G1" |
|----|------|------|------|------|------|-----|
| E  | 8    | 12   | 12   | 15   | 16,5 | 19  |
| E1 | 7    | 9    | 11   | 12   | 12   | 15  |

# high pressure ball valves

Legris **high pressure ball valves** are suitable for pressures up to 300 bar.

● **advantages**

- secure non removable inlet and outlet ports
- fixing holes for mounting assembly
- handle replaceable by a wheel
- excellent sealing at high and low pressure

● **constituent materials**

- body : hot stamped brass
- ball : polished brass
- ports : steel threaded
- stem : stainless steel
- handle : zamak
- "O" ring, stem seal and compensating "O" ring : nitrile

● **working temperature: -15° to +80°C**

## 4402 double female

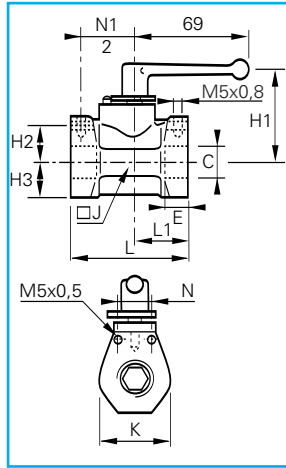

| C    | DN |            | E  | H1 | H2 | H3 | J  | K  | L  | L1 | N  | $\frac{N1}{2}$ | $\Delta$ kg |
|------|----|------------|----|----|----|----|----|----|----|----|----|----------------|-------------|
| G1/4 | 7  | 4402 07 13 | 12 | 50 | 13 | 15 | 30 | 30 | 58 | 25 | 15 | 20             | 0,374       |
| G3/8 | 10 | 4402 10 17 | 12 | 54 | 23 | 19 | 36 | 39 | 72 | 36 | 20 | 30             | 0,756       |
| G1/2 | 13 | 4402 13 21 | 15 | 56 | 23 | 21 | 40 | 42 | 79 | 36 | 20 | 30             | 0,839       |

## different methods for fixing

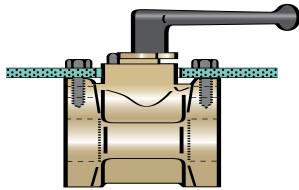

suspended mounting,  
fixed by two screws

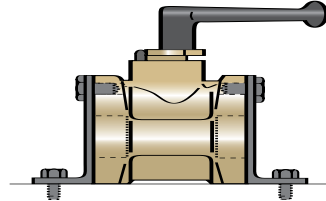

surface mounting,  
fixed by brackets and screws



# stainless steel ball valves

**Stainless steel series ball valves** are designed for use with corrosive fluids and in aggressive environments. Full bore, they are suited to higher pressure and high temperature applications. Therefore they can be used for a wide range of industrial applications.

2 versions:

- "3-piece" construction: allows the valve to be disassembled in situ, to facilitate maintenance.
- one piece construction

● **constituent materials :**

- body, ball, ports, stem : stainless steel 316 L
- handle, lock washer, stop pin : stainless steel 304 L
- nuts, gland seal : stainless steel 303 L
- screw: stainless steel 305 L
- ball seal, stem seal, anti-friction washer : PTFE
- "O" ring : FKM

## pressure and temperature resistance of stainless steel series ball valves 4832

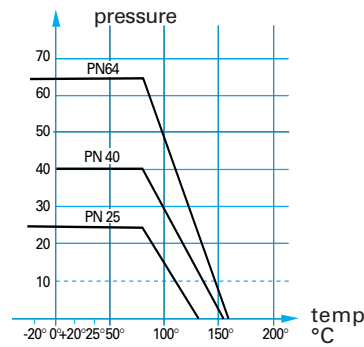

example : at 100°C  
 PN 64 becomes 48 bar  
 PN 40 becomes 30 bar  
 PN 25 becomes 17 bar  
 For temperatures between 150° and 200°, please consult us

## 4832 3 piece double female with lateral dismantling, BSP parallel

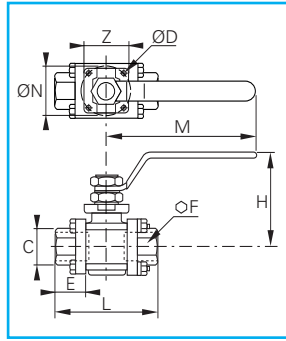

| C     | DN | PN          | ØD | E   | F    | H  | L    | M     | N     | Z  | kg    |
|-------|----|-------------|----|-----|------|----|------|-------|-------|----|-------|
| 1/4   | 10 | 4832 10 13  | 64 | -   | 18   | 22 | 50   | 57    | 110,5 | -  | 0,425 |
| 3/8   | 10 | 4832 10 17  | 64 | -   | 18   | 22 | 50   | 57    | 110,5 | -  | 0,400 |
| 1/2   | 15 | 4832 15 21  | 64 | 6   | 20,5 | 27 | 64   | 65    | 131,5 | 36 | 0,370 |
| 3/4   | 20 | 4832 20 27  | 40 | 5,5 | 22,5 | 32 | 68   | 76    | 131,5 | 42 | 0,555 |
| 1"    | 25 | 4832 25 34  | 40 | 6   | 27   | 41 | 78,5 | 92    | 174,5 | 42 | 1,035 |
| 1 1/4 | 32 | 4832 32 42* | 25 | 5,5 | 30   | 50 | 83,5 | 106,5 | 174,5 | 42 | 1,465 |
| 1 1/2 | 40 | 4832 40 49* | 25 | 6,5 | 31   | 55 | 100  | 116   | 250,5 | 50 | 1,995 |
| 2"    | 50 | 4832 50 48* | 25 | 6,5 | 36   | 70 | 107  | 136   | 250,5 | 50 | 3,140 |

\*models with CE marking

## 4812 double female, one piece, BSP parallel

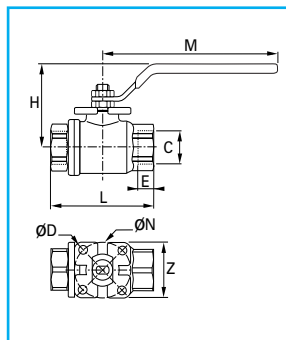

| C     | DN | PN          | ØD  | E   | H    | L   | M   | ØN  | Z  | kg    |
|-------|----|-------------|-----|-----|------|-----|-----|-----|----|-------|
| 1/4   | 10 | 4812 10 13  | 140 | 5,5 | 10   | 50  | 55  | 110 | 36 | 0,260 |
| 3/8   | 10 | 4812 10 17  | 140 | 5,5 | 11,4 | 50  | 55  | 110 | 36 | 0,240 |
| 1/2   | 15 | 4812 15 21  | 140 | 5,5 | 15   | 53  | 66  | 110 | 36 | 0,320 |
| 3/4   | 20 | 4812 20 27  | 105 | 5,5 | 16,3 | 67  | 79  | 130 | 42 | 0,540 |
| 1"    | 25 | 4812 25 34  | 105 | 5,5 | 19,1 | 79  | 93  | 175 | 42 | 0,990 |
| 1 1/4 | 32 | 4812 32 42* | 42  | 5,5 | 21,4 | 83  | 100 | 175 | 42 | 1,340 |
| 1 1/2 | 40 | 4812 40 49* | 42  | 5,5 | 21,4 | 100 | 110 | 250 | 50 | 2,140 |
| 2"    | 50 | 4812 50 48* | 42  | 8,5 | 25,7 | 107 | 131 | 250 | 70 | 3,360 |

\*models with CE marking

## 4810 double female, economy version, BSP parallel

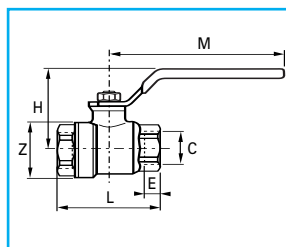

| C    | DN | PN         | E  | H  | L    | M    | Z     | kg   |       |
|------|----|------------|----|----|------|------|-------|------|-------|
| G1/4 | 8  | 4810 08 13 | 64 | 10 | 44,5 | 53,5 | 110,5 | 30   | 0,220 |
| G3/8 | 10 | 4810 10 17 | 64 | 10 | 44,5 | 53,5 | 110,5 | 30   | 0,200 |
| G1/2 | 15 | 4810 15 21 | 64 | 13 | 47   | 60   | 110,5 | 32,5 | 0,250 |
| G3/4 | 20 | 4810 20 27 | 40 | 14 | 54,5 | 70   | 131,5 | 40   | 0,450 |
| G1"  | 25 | 4810 25 34 | 40 | 17 | 58,5 | 79   | 131,5 | 49   | 0,850 |

Threads conform to ISO 228-1.

### Models 4832 - 4812

These valves have a fixing plate for the mounting of pneumatic or electrical actuators. The dimension of this plate conforms to standard ISO 5211. Threads conform to ISO 7-1 (Rp).

# compact stainless steel ball valves

Designed for use with many aggressive and corrosive fluids at pressures not exceeding 20 bar.

● **constituent materials of model 0465:**

- body, ball, ports, stem : stainless steel AISI 303
- handle : nickel-plated brass
- "O" ring, stem seal, ball seal : PTFE

**pressure and temperature resistance of compact stainless steel series ball valves 0465**

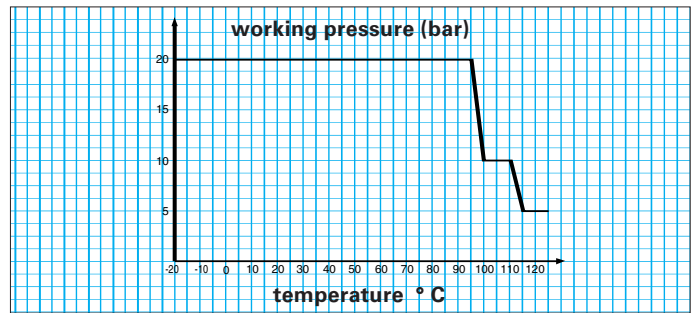

## 0465 double female

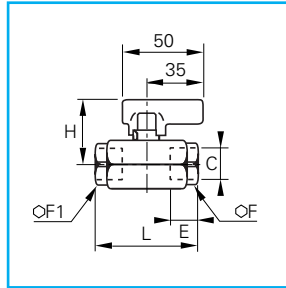

| C    | DN |            | PN | E  | F  | F1 | H  | L  | kg    |
|------|----|------------|----|----|----|----|----|----|-------|
| G1/4 | 4  | 0465 04 13 | 20 | 13 | 19 | 24 | 36 | 50 | 0,224 |
| G3/8 | 7  | 0465 07 17 | 20 | 13 | 24 | 27 | 39 | 55 | 0,278 |
| G1/2 | 10 | 0465 10 21 | 20 | 16 | 27 | 30 | 40 | 62 | 0,323 |

# Legris ball valves — quick reference table

Based on its successful standard range, Legris has developed a range of semi-**standard ball valves** in order to satisfy specific customer applications.

Six versions cover virtually all requirements for different types of fluids. Technical specifications are shown in the chart below.

To determine the minimum quantity of each model, please consult us.

On pages R24 to R27, an application table enables correct choice of valve depending on the fluid used.

## suffixes :

**20**

**22**

**26**

**27**

**30**

**32**



A colour coded band on the handle identifies each semi-standard version.

| semi-standard series     |                               |                            |  |               |                            |  |                                       |  |  |     |                    |                    |   |                    | examples of applications<br>(refer to the usage tables<br>overleaf for working<br>conditions) |
|--------------------------|-------------------------------|----------------------------|--|---------------|----------------------------|--|---------------------------------------|--|--|-----|--------------------|--------------------|---|--------------------|---|
| identification           |                               | body                       |  | handle        |                            |  | ball                                  |  | stem seal and<br>compensating "O" ring |     |                    | ball seal          |   |                    |   |
| Part<br>number<br>suffix | colour<br>= band<br>on handle | nickel-<br>plated<br>brass | chemically<br>nickel-<br>plated<br>brass | stan-<br>dard | nickel-<br>plated<br>brass | chemically<br>nickel-<br>plated<br>brass | nickel<br>plated<br>polished<br>brass | chemically<br>nickel-<br>plated<br>brass | ethylene<br>propy-<br>lene             | FKM | fluoro-<br>polymer | Rilsan<br>graphite | glass fibre<br>impreg-<br>nated<br>fluoro-<br>polymer | fluoro-<br>polymer |   |
| 20                       | Blue/Red                      | •                          |  | •             |                            |  | •                                     |  |  | •   |                    | •                  |   |                    | for hydrocarbons  |
| 22                       | Green/Blue                    | •                          |  | •             |                            |  |                                       | •  |  | •   |                    |                    | •   |                    | for slightly aggressive fluids<br>and high temperatures                                       |
| 26*                      | Yellow                        | •                          |  |               | •                          |  |                                       | •  |  |     |                    | ring               | •   | •                  | for aggressive liquids<br>or high temperatures  |
| 27                       | Blue/Green                    |                            | •  |               |                            | •  |                                       | •  |  | •   |                    |                    | •   |                    | for slightly aggressive fluids<br>and/or not very aggressive<br>environments                  |
| 30**                     | Red                           | •                          |  | •             |                            |  | •                                     |  | •                                      |     |                    | •                  |   |                    | for oxygen gas circuits   |
| 32                       | Green                         | •                          |  | •             |                            |  |                                       | •  | •                                      |     |                    |                    | •   |                    | for water and steam   |

\* degreased

\*\* grease compatible with oxygen

example of numbering systems for semi-standard ball valves

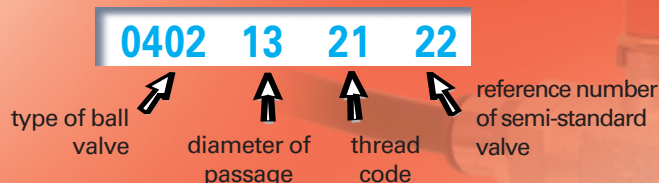

# Legris ball valves – application table

## Standard and semi-standard ranges

The following table covers ranges 0400 – 0401 – 0402 – 0411 – 0414 – 0432 – 0439 – 0469 – 0489 – 6401 – 6402.

For others part numbers please refer to the corresponding page of the catalogue for working pressures. Fluids and temperatures are as shown below

To find the maximum pressure of the valves below, with a 32 mm passage, divide by 2.

### How to find the fluid, look under :

1. First letter of the first word
2. First letter of the second word
3. In the synonym column

For the fluids, please consult us.

| PRODUCT                                 | SYNONYMS / USES                                 | Maximum Pressure<br>kg/cm <sup>2</sup> | Temperature<br>in C° |         | Standard | semi-standard |    |    |    |    |    |   |
|---|---|--|----------------------|---------|----------|---------------|----|----|----|----|----|---|
|   |   |  | min.                 | max.    |          | 20            | 22 | 26 | 27 | 30 | 32 |   |
| ABSOLUTE ALCOHOL                        |   | 20                                     | -20                  | Boi. pt |          |               |    |    |    |    |    | ● |
| ACETONE AND OTHER CETONES               | Methylacetyl - Propnone,                        | 20                                     | -20                  | +60     |          |               |    |    |    |    |    | ● |
|   | Dimethylacetone -Ketopropane                    |  |                      |         |          |               |    |    |    |    |    | ● |
| ACETOPHENONE                            | Phenylmethylketone,                             | 20                                     | -20                  | +60     |          |               |    |    |    |    |    | ● |
|   | Hypone Benzaylmethide                           | 20                                     | -20                  | +60     |          |               |    |    |    |    |    | ● |
| ACETYL - ACETONE                        |   |  |                      |         |          |               |    |    |    |    |    | ● |
| ACETYLENE (GAS)                         |   | 20                                     | -20                  | +60     | ●        |               |    |    |    |    |    |   |
| ALUMINA (LIQUID, PASTE OR SUSPENSION)   | Aluminium Oxide, Al <sub>2</sub> O <sub>3</sub> | 40                                     | -20                  | +90     | ●        |               |    |    |    |    |    |   |
| AMYL ALCOHOL                            | Methyl Butanols And Pentanols                   | 20                                     | -20                  | Boi. pt |          |               |    |    |    |    |    | ● |
| ANIMAL OIL                              |   | 20                                     | +5                   | +200    |          |               |    |    | ●  |    |    |   |
| ANTIFREEZE OR GLYCOL                    | Diluted Glycol Or Ethanediol                    | 40                                     | -20                  | +40     | ●        |               |    |    |    |    |    |   |
| ARGON GAS                               |   | 20                                     | -20                  | +60     | ●        |               |    |    |    |    |    |   |
| AUTOMOTIVE - BRAKE FLUID                |   | 20                                     | -20                  | +90     |          |               |    |    |    |    |    | ● |
| BARIUM HYDROXIDE                        | Barium Hydrate                                  | 20                                     | -20                  | +40     |          |               |    |    |    |    |    | ● |
| BENZALDEHYDE                            | Benzoicoldehyde, Benzol Hydride                 | 20                                     | -20                  | +60     |          |               |    |    |    |    |    | ● |
| BENZENE (OR BENZOL)                     | Benzene, Benzole, Benzine                       | 20                                     | -20                  | +60     |          |               |    |    |    |    |    | ● |
| BENZYL ALCOHOL                          | Hydroxytoluene Alphaphenyl,                     | 20                                     | -20                  | Boi. pt |          |               |    | ●  |    |    |    |   |
|   | Carbinol Pehnmethoyol                           |  |                      |         |          |               |    |    |    |    |    | ● |
| BORAX (PASTE OR LIQUID)                 |   | 20                                     | -20                  | +60     |          |               |    |    |    |    |    | ● |
| BROMOCHLOR TRIFLUOETHANE                | Freon   | 20                                     | -20                  | +60     |          |               |    |    | ●  |    |    |   |
| BUTADIENE (HYDROCARBON)                 | Erytrene Or Vinyl Ethylene                      | 20                                     | -20                  | +60     |          |               |    |    |    | ●  |    |   |
| BUTANE                                  |   | 20                                     | -20                  | +60     | ●        |               |    |    |    |    |    |   |
| BUTANOL                                 | Butyl-Alcohol                                   | 20                                     | -20                  | Boi. pt |          |               |    | ●  |    |    |    |   |
| BUTYL-ALCOHOL                           | Butanol 1                                       | 20                                     | -20                  | Boi. pt |          |               |    | ●  |    |    |    |   |
| BUTYLENE (HYDROCARBON)                  | Butene  | 20                                     | -20                  | +60     |          |               |    | ●  |    |    |    |   |
| CARBON DIOXIDE                          |   | 40                                     | -20                  | +60     | ●        |               |    |    |    |    |    |   |
| CASTOR OIL                              |   | 40                                     | -20                  | +90     | ●        |               |    |    |    |    |    |   |
| COLZA OIL                               | Oil Seed Rape                                   | 40                                     | -20                  | +90     | ●        |               |    |    |    |    |    |   |
| COMPRESSED AIR                          |   | 40                                     | -20                  | +100    | ●        |               |    |    |    |    |    |   |
| COPPER SULPHATE, LIME, SODIUM CARBONATE | Insecticide                                     | 20                                     | 0                    | +40     | ●        |               |    |    |    |    |    |   |
| CREOSOTE OIL                            |   | 20                                     | -20                  | +60     |          |               |    |    |    |    | ●  |   |
| CRESOLS                                 | Cresvsois                                       | 20                                     | -20                  | +60     |          |               |    |    |    |    | ●  |   |
| CUTTING OIL                             |   | 40                                     | -20                  | +90     | ●        |               |    |    |    |    |    |   |
| DECALIN (HYDROCARBON, SOLVENT)          | Decahydronaphtalene (Terpene)                   | 20                                     | -20                  | +60     |          |               |    |    |    |    |    | ● |

Note : because of the many specific environmental factors which might affect corrosion rate such as temperature and concentration, we would suggest that the chart be used as a rough guide to material selection and final acceptability be established by actual test under specific conditions.

# Legris ball valves – application table

## Standard and semi-standard ranges

| PRODUCT                                      | SYNONYMS / USES                    | Maximum Pressure<br>kg/cm <sup>2</sup> | Temperature in C° |         | Standard | semi-standard |    |    |    |    |    |   |
|--|------------------------------------|--|-------------------|---------|----------|---------------|----|----|----|----|----|---|
|  |                                    |  | min.              | max.    |          | 20            | 22 | 26 | 27 | 30 | 32 |   |
| DETERGENT SOLUTION                           | Cleaning Fluid                     | 20                                     | -20               | +100    |          |               |    |    |    |    |    | ● |
| DIACETONE ALCOHOL                            |                                    | 20                                     | -20               | Boi. pt |          |               |    |    |    |    |    | ● |
| DIESEL OIL                                   |                                    | 40                                     | -20               | +90     | ●        |               |    |    |    |    |    |   |
| DI-ESTERS                                    | Synthetic Lubricant                | 20                                     | -20               | +90     |          |               |    | ●  |    |    |    |   |
| DI-ISO-BUTYLENE                              | Solvent For Resin Preparation      | 20                                     | -20               | +60     |          |               |    |    |    | ●  |    |   |
| DI-PENTANE                                   | Aliphatic Hydrocarbon              | 20                                     | -20               | +60     |          |               |    | ●  |    |    |    |   |
| DI-PENTENE                                   | Solvent Varnish                    | 20                                     | -20               | +60     |          |               |    | ●  |    |    |    |   |
| DI-PHENYL-OXIDE (MOULDING DETERGENT)         | Coumarone Or Biphénylene Oxyde     | 20                                     | -20               | +60     |          |               |    |    |    |    | ●  |   |
| DISTILLED WATER                              |                                    | 40                                     |                   | +90     | ●        |               |    |    |    |    |    |   |
| EDIBLE FAT                                   | Liquid Or Paste Up To 200 °C       | 20                                     | +5                | +200    |          |               |    |    |    | ●  |    |   |
| EDIBLE OIL                                   | Up To 200 °C                       | 20                                     | +5                | +200    |          |               |    |    |    | ●  |    |   |
| ERYTRENE (SEE BUTADIENE)                     | Hydrocarbon Vinyl-Ethylene         | 20                                     | -20               | +60     |          |               |    |    |    |    | ●  |   |
| ETHANE (HYDROCARBON GAS)                     |                                    | 20                                     | -20               | +60     |          |               |    |    |    |    | ●  |   |
| ETHANE GAS CH <sub>3</sub> CH <sub>3</sub>   |                                    | 20                                     | -20               | +60     | ●        |               |    |    |    |    |    |   |
| ETHANEDIOL (SEE GLYCOL) ANTIFREEZE           | Ordinary Glycol Or Ethylene-Glycol | 20                                     | -20               | +120    |          |               |    |    |    |    |    | ● |
| ETHYL ALCOHOL                                |                                    | 20                                     | -20               | Boi. pt |          |               |    |    |    |    |    | ● |
| ETHYL ALCOHOL                                | Ethanol                            | 20                                     | -20               | +60     |          |               |    |    |    |    |    | ● |
| ETHYLENE GLYCOL                              | Antifreeze Lubricant               | 20                                     | -20               | +120    |          |               |    |    |    |    |    | ● |
| FATTY ALCOHOL                                |                                    | 20                                     | -20               |         |          |               | ●  |    |    |    |    |   |
| FLAX OIL                                     |                                    | 40                                     | -20               | +90     | ●        |               |    |    |    |    |    |   |
| FUEL   |                                    | 40                                     | -20               | +40     | ●        |               |    |    |    |    |    |   |
| FUEL OIL                                     |                                    | 40                                     | -20               | +40     | ●        |               |    |    |    |    |    |   |
| GLYCERIN                                     | Glycerol Or Propanetriol           | 20                                     | -20               | +40     | ●        |               |    |    |    |    |    |   |
| GLYCOL (FOR ANTIFREEZE, LUBRICANT)           | Ethylene Glycol                    | 40                                     | -20               | +40     | ●        |               |    |    |    |    |    |   |
| GRAPHITE (INSUSPENSION WITH WATER, OIL, FAT) |                                    | 40                                     | -20               | +90     | ●        |               |    |    |    |    |    |   |
| HELIUM (GAS)                                 | Degreasing compulsory              | 20                                     | -20               | +60     |          |               |    |    |    |    |    | ● |
| HEPTANAL                                     |                                    | 20                                     | -20               | +50     | ●        |               |    |    |    |    |    |   |
| HEXANE (SOLVENT)                             |                                    | 20                                     | -20               | +60     |          |               |    |    |    |    |    | ● |
| HIGH OCTANE PETROL                           | Automotive or Aerospace            | 20                                     | -20               | +40     |          |               | ●  |    |    |    |    |   |
| HYDRAULIC OIL                                | Petroleum Based                    | 40                                     | -20               | +90     | ●        |               |    |    |    |    |    |   |
| HYDROCARBONS - AROMATIC                      |                                    | 20                                     | -20               | +60     |          |               |    | ●  |    |    |    |   |
| HYDROGEN GAS - AMBIENT TEMPERATURE           | Completely Degreased Valve         | 20                                     | -20               | +60     |          |               |    |    |    |    |    | ● |
| HYDROGEN PEROXID                             |                                    | 40                                     | -20               | +30     |          |               | ●  |    |    |    |    |   |
| INK  | Printing                           | 20                                     | -20               | +60     |          |               |    |    |    |    | ●  |   |
| ISO-BUTANE                                   | Methyl, Propane                    | 20                                     | -20               | +60     |          |               |    |    |    |    | ●  |   |
| ISO-OCTANE                                   |                                    | 20                                     | -20               | +60     |          |               |    |    |    |    | ●  |   |
| ISOPROPYL ALCOHOL                            | Propanol 2                         | 20                                     | -20               | Boi. pt |          |               |    |    |    |    |    | ● |
| KRYPTON GAS KR                               |                                    | 20                                     | -20               | +60     | ●        |               |    |    |    |    |    |   |
| LIGHTING GAS                                 |                                    | 20                                     | -20               | +40     | ●        |               |    |    |    |    |    |   |
| LUBRICATING OIL                              | Petrol based                       | 40                                     | -20               | +90     | ●        |               |    |    |    |    |    |   |

Note : because of the many specific environmental factors which might affect corrosion rate such as temperature and concentration, we would suggest that the chart be used as a rough guide to material selection and final acceptability be established by actual test under specific conditions.



# Legris ball valves – application table

## Standard and semi-standard ranges

| PRODUCT   | SYNONYMS / USES                    | Maximum Pressure<br>kg/cm <sup>2</sup> | Temperature in C° |         | Standard | semi-standard |    |    |    |    |    |   |   |
|---|------------------------------------|--|-------------------|---------|----------|---------------|----|----|----|----|----|---|---|
|   |                                    |  | min.              | max.    |          | 20            | 22 | 26 | 27 | 30 | 32 |   |   |
| METHANE GAS CH <sub>4</sub>                               |                                    | 20                                     | -20               | +60     | ●        |               |    |    |    |    |    |   |   |
| METHANOL  | Methyl Alcohol                     | 20                                     | -20               | Boi. pt |          |               |    |    |    |    |    |   | ● |
| METHYL ALCOHOL  | Methanol 1                         | 20                                     | -20               | Boi. pt |          |               |    |    |    |    |    |   | ● |
| METHYL ALCOHOL (SOLVENT)                                  | Methanol                           | 20                                     | -20               | Boi. pt |          |               |    |    |    |    |    |   | ● |
| MINERAL OIL   |                                    | 40                                     | -20               | +90     | ●        |               |    |    |    |    |    |   |   |
| MINERAL PETROLEUM OIL                                     | Up To 160 °C                       | 20                                     | -20               | +160    |          |               | ●  |    |    |    |    |   |   |
| NATURAL WAXES (VEGETABLE, BEES, CARNAUCA, CHINA, LIGNITE) |                                    | 40                                     | -20               | +90     |          |               |    | ●  |    |    |    |   |   |
| NATURAL GAS   |                                    | 20                                     | -20               | +40     | ●        |               |    |    |    |    |    |   |   |
| NEON GAS NE   |                                    | 20                                     | -20               | +60     | ●        |               |    |    |    |    |    |   |   |
| NITROGEN GAS N <sub>2</sub>                               |                                    | 40                                     | -20               | +90     | ●        |               |    |    |    |    |    |   |   |
| ORDINARY PETROL   |                                    | 20                                     | -20               | +40     | ●        |               |    |    |    |    |    |   |   |
| ORDINARY WATER  |                                    | 40                                     |                   | +80     | ●        |               |    |    |    |    |    |   |   |
| OXYGEN (AMBIENT TEMPERATURE)                              | Degreased                          | 20                                     | -20               | +40     |          |               |    |    |    |    |    |   | ● |
| PAINT AND RELEVANT SOLVENTS                               |                                    | 20                                     | -20               | +60     |          |               |    | ●  |    |    |    |   |   |
| PARAFFIN  | Ozokerite                          | 20                                     | -20               | +60     | ●        |               |    |    |    |    |    |   |   |
| PARAFFIN OIL  |                                    | 40                                     | -20               | +90     | ●        |               |    |    |    |    |    |   |   |
| PENTANE (LIQUID HYDROCARBON)                              |                                    | 20                                     | -20               | +60     | ●        |               |    |    |    |    |    |   |   |
| PENTANOLS 1 AND 2   | Amylic Alcohol Or Methyl Butanol   | 20                                     | -20               | Boi. pt |          |               |    |    |    |    |    |   | ● |
| PETROLEUM   |                                    | 20                                     | -20               | +40     |          |               | ●  |    |    |    |    |   |   |
| PETROLEUM FAT   |                                    | 40                                     | -20               | +90     | ●        |               |    |    |    |    |    |   |   |
| PETROLEUM OIL AND EMULSION WATER                          |                                    | 40                                     | -20               | +90     | ●        |               |    |    |    |    |    |   |   |
| PHENOL (ALCOHOLIC OR AQUEOUS SOLUTION)                    | Phenic Or Carbonic Acid            | 20                                     | -20               | +60     |          |               |    | ●  |    |    |    |   |   |
| PROPANE   |                                    | 20                                     | -20               | +60     | ●        |               |    |    |    |    |    |   |   |
| PROPANOLS 1 AND 2   | Propyl Alcohol And Isopropyl       | 20                                     | -20               | Boi. pt | ●        |               |    |    |    |    |    |   |   |
| PROPENE OR PROPYLENE                                      | Various Preparations - Synthetic   | 20                                     | -20               | +60     |          |               | ●  |    |    |    |    |   |   |
| PROPYL ALCOHOL  | Propanol                           | 20                                     | -20               | Boi. pt |          |               |    |    |    |    |    |   | ● |
| SAPONIFYING LIQUIDS                                       |                                    | 20                                     |                   | +30     | ●        |               |    |    |    |    |    |   |   |
| SEA WATER   |                                    | 40                                     |                   | +80     | ●        |               |    |    |    |    |    |   |   |
| SEA WATER - HIGH TEMPERATURE                              |                                    | 20                                     |                   | +150    |          |               |    |    |    |    |    | ● |   |
| SOAP  | Liquid, Paste, Solutions           | 20                                     | -20               | +40     |          |               |    |    |    |    |    |   | ● |
| SOAP (LIQUID OR PASTE)                                    |                                    | 40                                     | -20               | +100    | ●        |               |    |    |    |    |    |   |   |
| SODIUM CARBONATE (WITH WATER)                             | Carbonated Water                   | 20                                     | 0                 | +40     | ●        |               |    |    |    |    |    |   |   |
| STARCH - GELS OR PASTE (GLUE, COSMETICS) C6H10O5          |                                    | 40                                     | +10               | +40     | ●        |               |    |    |    |    |    |   |   |
| STEAM AT 150 °C MAXI                                      |                                    | 20                                     |                   | +150    |          |               |    |    |    |    |    |   | ● |
| SYNTHETIC OIL   |                                    | 20                                     | -20               | +100    |          |               |    |    |    |    |    |   | ● |
| TOLUENE   | Methyl-Benzene (Solvent,Synthetic) | 20                                     | -20               | +60     |          |               |    | ●  |    |    |    |   |   |
| TRICHLOROETHYLENE   | Fatting Solvent                    | 20                                     | -20               | +65     |          |               | ●  |    |    |    |    |   |   |

Note : because of the many specific environmental factors which might affect corrosion rate such as temperature and concentration, we would suggest that the chart be used as a rough guide to material selection and final acceptability be established by actual test under specific conditions.

# Legris ball valves – application table

## Standard and semi-standard ranges

| PRODUCT                   | SYNONYMS / USES               | Maximum Pressure<br>kg/cm <sup>2</sup> | Temperature in C° |      | Standard | semi-standard |    |    |    |    |    |  |  |   |
|---------------------------|-------------------------------|--|-------------------|------|----------|---------------|----|----|----|----|----|--|--|---|
|                           |                               |  | min.              | max. |          | 20            | 22 | 26 | 27 | 30 | 32 |  |  |   |
| TURPENTINE                | Turps                         | 20                                     | -20               | +50  | ●        |               |    |    |    |    |    |  |  |   |
| VARNISH AND PAINT         | And Relevant Solvent          | 20                                     | -20               | +60  |          |               |    |    | ●  |    |    |  |  |   |
| VASELINE                  |                               | 40                                     | -20               | +60  | ●        |               |    |    |    |    |    |  |  |   |
| VASELINE OIL              |                               | 40                                     | -20               | +90  | ●        |               |    |    |    |    |    |  |  |   |
| WATER - HIGH TEMPERATURE  |                               | 20                                     |                   | +150 |          |               |    |    |    |    |    |  |  | ● |
| WATER WITH CARBONATED GAS |                               | 40                                     |                   | +90  | ●        |               |    |    |    |    |    |  |  |   |
| WHITE SPIRIT              | Mix Of Methyl,                |  |                   |      | ●        |               |    |    |    |    |    |  |  |   |
|                           | And Ethyl Alcohol And Acetone | 40                                     | -20               | -40  | ●        |               |    |    |    |    |    |  |  |   |
| XENON (GAS) XE            |                               | 20                                     | -20               | +60  | ●        |               |    |    |    |    |    |  |  |   |
| XYLENE                    |                               | 20                                     | -20               | +60  |          |               |    |    | ●  |    |    |  |  |   |
|                           |                               |  |                   |      |          |               |    |    |    |    |    |  |  |   |
|                           |                               |  |                   |      |          |               |    |    |    |    |    |  |  |   |
|                           |                               |  |                   |      |          |               |    |    |    |    |    |  |  |   |
|                           |                               |  |                   |      |          |               |    |    |    |    |    |  |  |   |
|                           |                               |  |                   |      |          |               |    |    |    |    |    |  |  |   |
|                           |                               |  |                   |      |          |               |    |    |    |    |    |  |  |   |
|                           |                               |  |                   |      |          |               |    |    |    |    |    |  |  |   |
|                           |                               |  |                   |      |          |               |    |    |    |    |    |  |  |   |

Note : because of the many specific environmental factors which might affect corrosion rate such as temperature and concentration, we would suggest that the chart be used as a rough guide to material selection and final acceptability be established by actual test under specific conditions.

# principle of needle valves

**Legris needle valves** are designed for use where a combination of fluid control and perfect sealing is required.

They incorporate a wide selection of port configurations to ensure simple assembly in any system.

## technical specifications

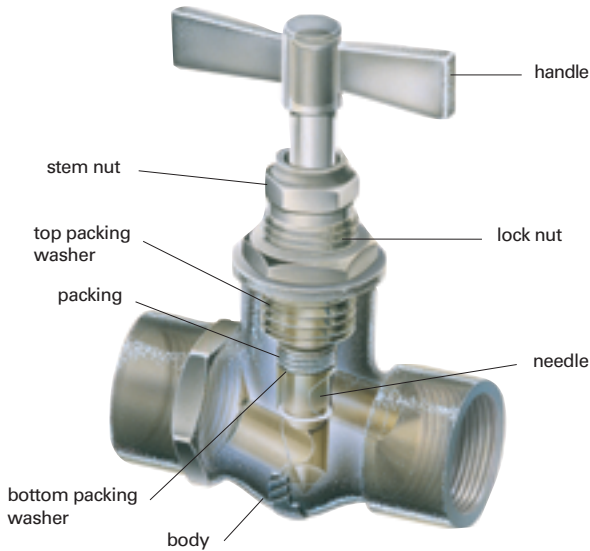

**Maximum working pressure**

120 bar

**Working temperature**

from - 20° C to + 100 ° C  
(except 0510)

**constituent materials**

body : sandblasted nickel plated brass  
handle : zamac or nickel plated brass  
needle : nickel plated brass  
stem nut : nickel plated brass (except 0510)  
lock nut : nickel plated brass  
washers : brass (except 0510)  
packing : graphite impregnated asbestos

## 0502 in-line double female, BSP parallel



sand blasted nickel plated brass

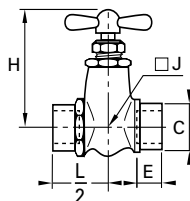

| C    | DN |            | E  | H<br>maxi | H<br>mini | J  | $\frac{L}{2}$ | $\Delta$ kg |
|------|----|------------|----|-----------|-----------|----|---------------|-------------|
| G1/8 | 4  | 0502 04 10 | 9  | 56        | 50        | 17 | 23            | 0,110       |
| G1/4 | 4  | 0502 04 13 | 11 | 56        | 50        | 17 | 23            | 0,110       |
| G3/8 | 6  | 0502 06 17 | 12 | 67        | 60        | -  | 26            | 0,160       |
| G3/8 | 9  | 0502 09 17 | 12 | 82        | 70        | -  | 33            | 0,410       |

## 0501 in-line male/female, BSP parallel



sand blasted nickel plated brass

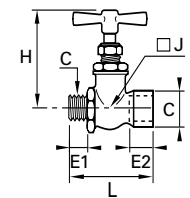

| C    | DN |            | E1  | E2 | H<br>maxi | H<br>mini | J  | L  | $\Delta$ kg |
|------|----|------------|-----|----|-----------|-----------|----|----|-------------|
| G1/8 | 4  | 0501 04 10 | 7   | 9  | 56        | 50        | 17 | 44 | 0,105       |
| G1/4 | 4  | 0501 04 13 | 9,5 | 11 | 56        | 50        | 17 | 46 | 0,110       |
| G3/8 | 6  | 0501 06 17 | 9,5 | 12 | 67        | 60        | -  | 48 | 0,155       |

## 0510 in-line economy valve with compression couplings



sand blasted nickel plated brass

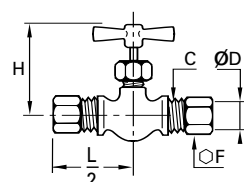

| ØD | DN |            | C      | F  | H<br>maxi | H<br>mini | $\frac{L}{2}$ | $\Delta$ kg |
|----|----|------------|--------|----|-----------|-----------|---------------|-------------|
| 6  | 4  | 0510 04 06 | 10x100 | 13 | 46        | 42        | 29            | 0,090       |
| 8  | 5  | 0510 05 08 | 12x100 | 14 | 46        | 42        | 30            | 0,090       |
| 10 | 5  | 0510 05 10 | 16x150 | 19 | 46        | 42        | 31            | 0,110       |

The needle is sealed by an "O" ring  
Maximum operating pressure Ø4 : 100 bar  
Ø5 : 60 bar  
Working temperature : -15°C to +70°C

# needle valves

## 0532 right angled double female, BSP parallel

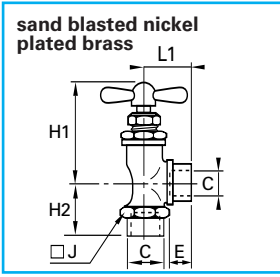

| C    | DN |            | E  | H<br>maxi | H1<br>mini | H2 | J  | L1 | kg    |
|------|----|------------|----|-----------|------------|----|----|----|-------|
| G1/8 | 4  | 0532 04 10 | 9  | 52        | 46         | 19 | 17 | 19 | 0,085 |
| G1/4 | 4  | 0532 04 13 | 11 | 52        | 46         | 21 | 17 | 21 | 0,095 |
| G1/4 | 6  | 0532 06 13 | 11 | 63        | 55         | 26 | 22 | 26 | 0,175 |

## 0531 right angled male/female, BSP parallel

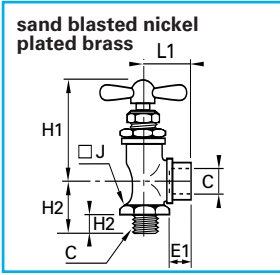

| C    | DN |            | E1  | E2 | H<br>maxi | H1<br>mini | H2 | J  | L1 | kg    |
|------|----|------------|-----|----|-----------|------------|----|----|----|-------|
| G1/8 | 4  | 0531 04 10 | 7   | 9  | 52        | 46         | 19 | 17 | 19 | 0,080 |
| G1/4 | 4  | 0531 04 13 | 9,5 | 11 | 52        | 46         | 21 | 17 | 21 | 0,085 |
| G1/4 | 6  | 0531 06 13 | 9,5 | 11 | 63        | 55         | 25 | 22 | 26 | 0,170 |
| G3/8 | 6  | 0531 06 17 | 9,5 | 12 | 63        | 55         | 25 | 22 | 27 | 0,195 |
| G1/2 | 10 | 0531 10 21 | 13  | 16 | 72        | 62         | 34 | 26 | 33 | 0,310 |

## 0562 needle drain valve, BSP parallel or metric

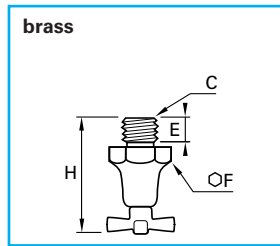

| C     | DN |            | E  | F  | H<br>maxi | H<br>mini | kg    |
|-------|----|------------|----|----|-----------|-----------|-------|
| G1/8  | 5  | 0562 05 10 | 8  | 16 | 40        | 36        | 0,035 |
| M10x1 | 5  | 0562 05 60 | 8  | 16 | 40        | 37,5      | 0,035 |
| G1/4  | 5  | 0562 05 13 | 10 | 19 | 42,5      | 38,5      | 0,040 |

## 0563 needle drain valve, NPT

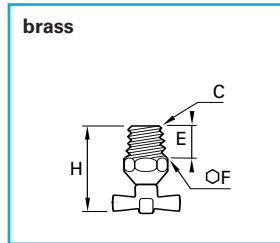
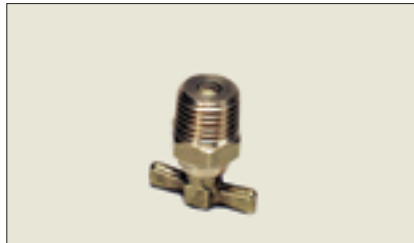

| C   | DN |            | E  | F  | H<br>maxi | H<br>mini | kg    |
|-----|----|------------|----|----|-----------|-----------|-------|
| 1/4 | 5  | 0563 05 14 | 10 | 14 | 32,5      | 28,5      | 0,060 |

## 0627 automatically venting double female pressure gauge valve

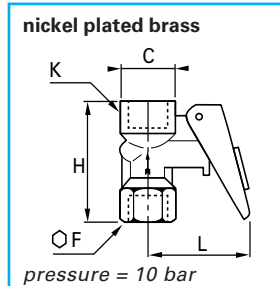

| C    |  |            | F  | H    | K  | L<br>maxi | L<br>mini | kg    |
|------|--|------------|----|------|----|-----------|-----------|-------|
| G1/4 |  | 0627 00 13 | 19 | 43,5 | 20 | 22        | 40        | 0,100 |

This isolating valve is used to connect a pressure gauge to a circuit. Resetting the lever isolates and vents the gauge. A locking pin can be used to enable the gauge to be fitted permanently.

## 0630 pressure relief valve BSP parallel

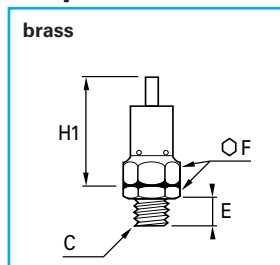

| C    | DN |            | E | F  | H1   | kg    |
|------|----|------------|---|----|------|-------|
| G1/4 | 6  | 0630 06 13 | 9 | 17 | 42,5 | 0,100 |

This valve is delivered without calibration, but can be adjusted by inserting metal washers into the hexagon (F).

# Principle of the Axial valve

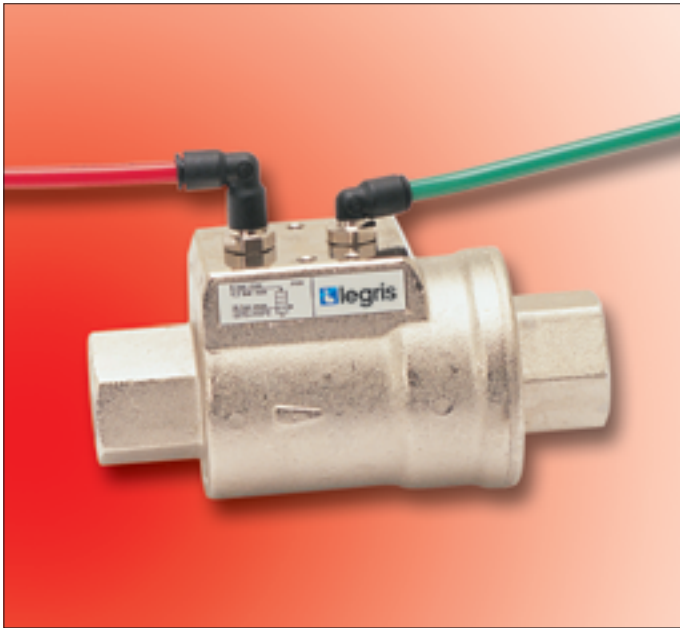

Designed with a view to overcoming the limitations of traditional actuators, the **Legris axial valve** offers the functions of a valve fitted with an actuator. A pneumatic automation device is fitted directly into the valve.

Its operation is not affected by the up/downstream pressures of the transported fluids, which guarantees the user total safety and a vastly simplified choice.

### Principal advantages:

- **compactness:** the axial valve is extremely compact and requires up to 50% **less space** than an actuated valve.
- **costs less** than an actuated valve: a single unit which controls the following two functions at the same time opening/closing of circuit and actuation of this function.
- high **performance:** full flow, compatible with numerous industrial fluids
- straightforward reliable installation: **ready to fit.**

## technical specifications

|  |                                 |   |
|--|---------------------------------|---|
|  | <b>transported fluid</b>        | - all fluids compatible with :<br>● FKM : water, air, oils, greases...<br>● EPDM : hot water, air, steam... |
|  | <b>maximum working pressure</b> | 10 bar  |
|  | <b>maximum temperature</b>      | with FKM seal + 135° C<br>with EPDM seal + 120° C   |
|  | <b>minimum temperature</b>      | - 20°C  |
|  | <b>vacuum capability</b>        | 740 mm Hg (97,4% vacuum).   |
|  | <b>pilot fluid</b>              | filtered compressed air   |
|  | <b>pilot pressure</b>           | NC and NO : 4,2 to 8 bar<br>double acting : 3 to 8 bar  |



# axial valve

## operation

Depending upon the operational requirement, air is passed into the actuation chamber, as shown below, in order to open or close the valve.

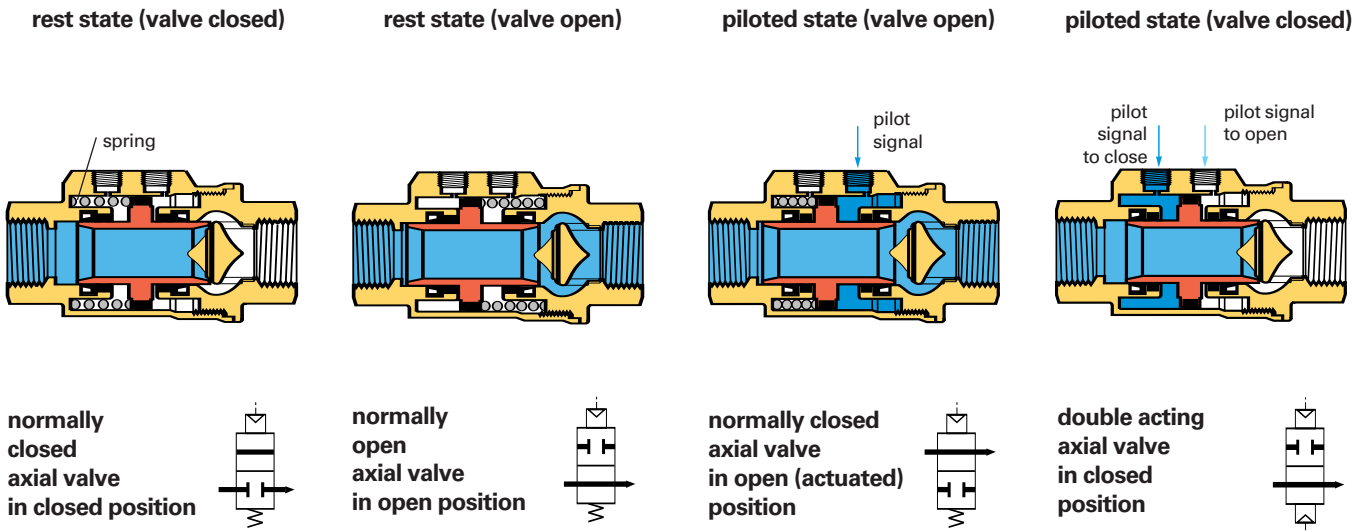

## which control method ?

The **Legris** axial valve offers three different control methods dependant on the requirements of the installation:

### pneumatic control

example : 4222 axial valve, double acting

- on-site control.
- for **repetitive** on/off cycles.
- remote control in case of **difficulty of access** to a machine.

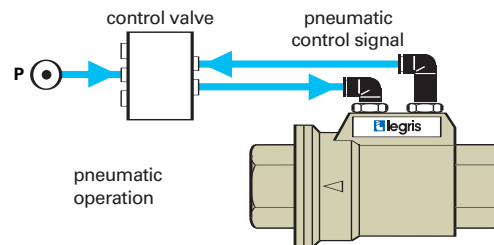

### electro-pneumatic control

example :

4202 axial valve, normally closed  
+ 4298 mini-solenoid valve and subbase

- for industrial automation requiring **remote control**.

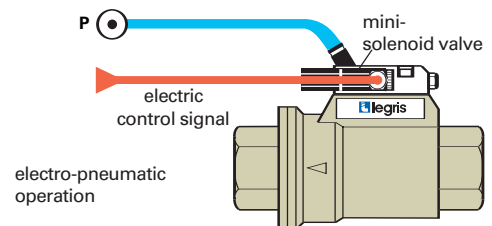

### pneumatic/electro-pneumatic dual control

example :

4212 axial valve, normally open  
+ 4298 mini-solenoid valve and subbase  
+ 4299 switch

- dual control structure
- for increased safety :
- prevents all localized operating errors.

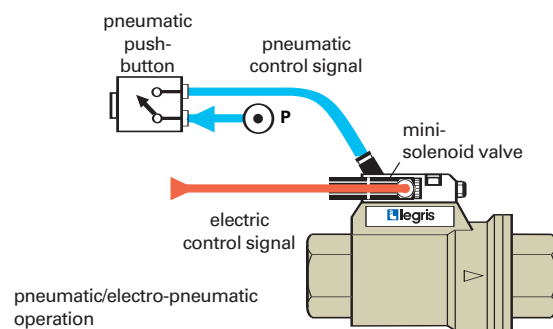

# axial valve

## 4202 normally closed, double female, BSP parallel

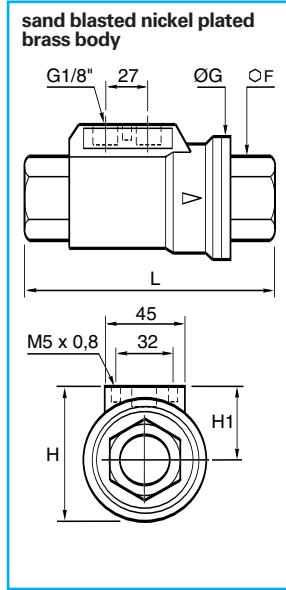

| C      | DN | FKM seal       | F  | G   | H   | H1   | L   | kg    |
|--------|----|----------------|----|-----|-----|------|-----|-------|
| G3/8   | 10 | 4202 10 17 20  | 22 | 46  | 54  | 31   | 98  | 0,814 |
| G1/2   | 15 | 4202 15 21 20  | 27 | 52  | 60  | 35   | 112 | 1,085 |
| G3/4   | 20 | 4202 20 27 20  | 33 | 64  | 70  | 38   | 135 | 1,634 |
| G1"    | 25 | 4202 25 34 20  | 41 | 69  | 76  | 41,5 | 143 | 2,024 |
| G1"1/4 | 32 | 4202 32 42 20* | 50 | 86  | 91  | 48   | 165 | 3,301 |
| G1"1/2 | 40 | 4202 40 49 20* | 60 | 96  | 102 | 54   | 180 | 4,180 |
| G2"    | 50 | 4202 50 48 20* | 75 | 109 | 115 | 60,5 | 207 | 6,360 |

| C      | DN | EPDM seal      | F  | G   | H   | H1   | L   | kg    |
|--------|----|----------------|----|-----|-----|------|-----|-------|
| G3/8   | 10 | 4202 10 17 30  | 22 | 46  | 54  | 31   | 98  | 0,814 |
| G1/2   | 15 | 4202 15 21 30  | 27 | 52  | 60  | 35   | 112 | 1,085 |
| G3/4   | 20 | 4202 20 27 30  | 33 | 64  | 70  | 38   | 135 | 1,634 |
| G1"    | 25 | 4202 25 34 30  | 41 | 69  | 76  | 41,5 | 143 | 2,024 |
| G1"1/4 | 32 | 4202 32 42 30* | 50 | 86  | 91  | 48   | 165 | 3,301 |
| G1"1/2 | 40 | 4202 40 49 30* | 60 | 96  | 102 | 54   | 180 | 4,180 |
| G2"    | 50 | 4202 50 48 30* | 75 | 109 | 115 | 60,5 | 207 | 6,360 |

Pilot port : 1/8" BSP parallel  
Complete with M5 silencer

## 4212 normally open, double female, BSP parallel

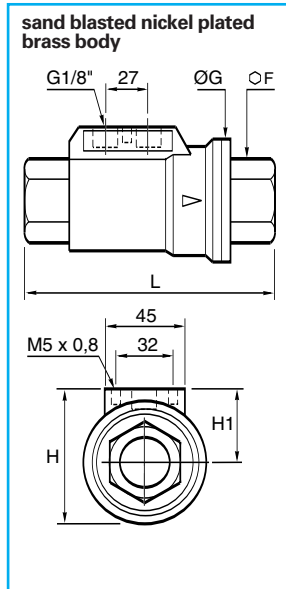

| C      | DN | FKM seal       | F  | G   | H   | H1   | L   | kg    |
|--------|----|----------------|----|-----|-----|------|-----|-------|
| G3/8   | 10 | 4212 10 17 20  | 22 | 46  | 54  | 31   | 98  | 0,814 |
| G1/2   | 15 | 4212 15 21 20  | 27 | 52  | 60  | 35   | 112 | 1,085 |
| G3/4   | 20 | 4212 20 27 20  | 33 | 64  | 70  | 38   | 135 | 1,634 |
| G1"    | 25 | 4212 25 34 20  | 41 | 69  | 76  | 41,5 | 143 | 2,024 |
| G1"1/4 | 32 | 4212 32 42 20* | 50 | 86  | 91  | 48   | 165 | 3,301 |
| G1"1/2 | 40 | 4212 40 49 20* | 60 | 96  | 102 | 54   | 180 | 4,180 |
| G2"    | 50 | 4212 50 48 20* | 75 | 109 | 115 | 60,5 | 207 | 6,360 |

| C      | DN | EPDM seal      | F  | G   | H   | H1   | L   | kg    |
|--------|----|----------------|----|-----|-----|------|-----|-------|
| G3/8   | 10 | 4212 10 17 30  | 22 | 46  | 54  | 31   | 98  | 0,814 |
| G1/2   | 15 | 4212 15 21 30  | 27 | 52  | 60  | 35   | 112 | 1,085 |
| G3/4   | 20 | 4212 20 27 30  | 33 | 64  | 70  | 38   | 135 | 1,634 |
| G1"    | 25 | 4212 25 34 30  | 41 | 69  | 76  | 41,5 | 143 | 2,024 |
| G1"1/4 | 32 | 4212 32 42 30* | 50 | 86  | 91  | 48   | 165 | 3,301 |
| G1"1/2 | 40 | 4212 40 49 30* | 60 | 96  | 102 | 54   | 180 | 4,180 |
| G2"    | 50 | 4212 50 48 30* | 75 | 109 | 115 | 60,5 | 207 | 6,360 |

Pilot port : 1/8" BSP parallel  
Complete with M5 silencer

## 4222 double acting, double female, BSP parallel

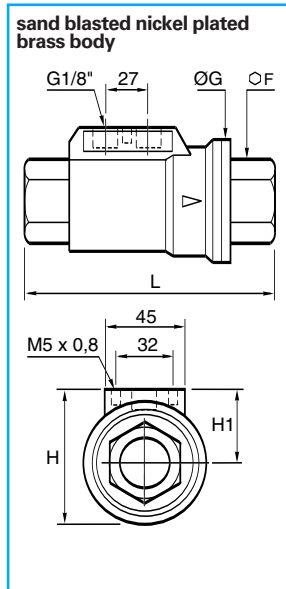

| C      | DN | FKM seal       | F  | G   | H   | H1   | L   | kg    |
|--------|----|----------------|----|-----|-----|------|-----|-------|
| G3/8   | 10 | 4222 10 17 20  | 22 | 46  | 54  | 31   | 98  | 0,814 |
| G1/2   | 15 | 4222 15 21 20  | 27 | 52  | 60  | 35   | 112 | 1,085 |
| G3/4   | 20 | 4222 20 27 20  | 33 | 64  | 70  | 38   | 135 | 1,634 |
| G1"    | 25 | 4222 25 34 20  | 41 | 69  | 76  | 41,5 | 143 | 2,024 |
| G1"1/4 | 32 | 4222 32 42 20* | 50 | 86  | 91  | 48   | 165 | 3,301 |
| G1"1/2 | 40 | 4222 40 49 20* | 60 | 96  | 102 | 54   | 180 | 4,180 |
| G2"    | 50 | 4222 50 48 20* | 75 | 109 | 115 | 60,5 | 207 | 6,360 |

| C      | DN | EPDM seal      | F  | G   | H   | H1   | L   | kg    |
|--------|----|----------------|----|-----|-----|------|-----|-------|
| G3/8   | 10 | 4222 10 17 30  | 22 | 46  | 54  | 31   | 98  | 0,814 |
| G1/2   | 15 | 4222 15 21 30  | 27 | 52  | 60  | 35   | 112 | 1,085 |
| G3/4   | 20 | 4222 20 27 30  | 33 | 64  | 70  | 38   | 135 | 1,634 |
| G1"    | 25 | 4222 25 34 30  | 41 | 69  | 76  | 41,5 | 143 | 2,024 |
| G1"1/4 | 32 | 4222 32 42 30* | 50 | 86  | 91  | 48   | 165 | 3,301 |
| G1"1/2 | 40 | 4222 40 49 30* | 60 | 96  | 102 | 54   | 180 | 4,180 |
| G2"    | 50 | 4222 50 48 30* | 75 | 109 | 115 | 60,5 | 207 | 6,360 |

Pilot port : 1/8" BSP parallel

Face plate in accordance with recommendations in force (NAMUR). \*Models with CE marking

# axial valve

## 4298 subbase for solenoid pilot valve



anodized aluminium

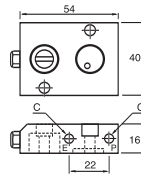

|        |            |       |
|--------|------------|-------|
| C      |            |       |
| M5x0,8 | 4298 00 01 | 0,094 |

The subbase is fitted directly to the axial valve and permits the mounting of a 15x15 solenoid valve.

Supplied with 2 fixing bolts, silencer and seals

## 4298 mini-solenoid valve 1W/1,2VA

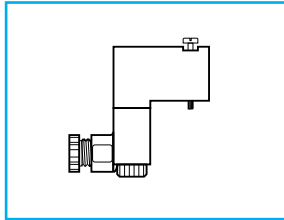

|         |            |
|---------|------------|
| voltage |            |
| 24V === | 4298 01 01 |
| 24V ~   | 4298 01 02 |
| 110V ~  | 4298 02 01 |
| 220V ~  | 4298 02 02 |

## 4299 pneumatic button/electro-pneumatic

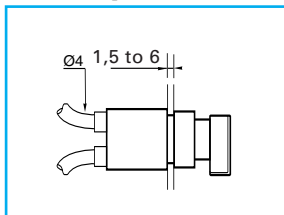

|                     |            |
|---------------------|------------|
| 1 pneumatic contact |            |
| standard            | 4299 01 01 |
| with key            | 4299 01 02 |

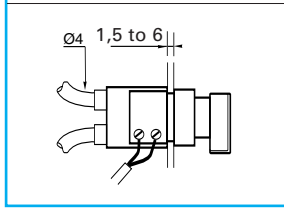
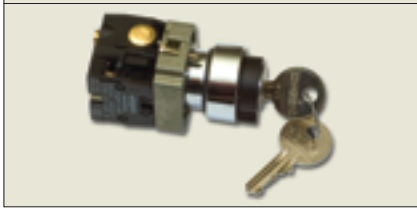

|                             |            |
|-----------------------------|------------|
| 1 electro-pneumatic contact |            |
| standard                    | 4299 02 01 |
| with key                    | 4299 02 02 |

Bulkhead fixing hole diameter : 22 mm

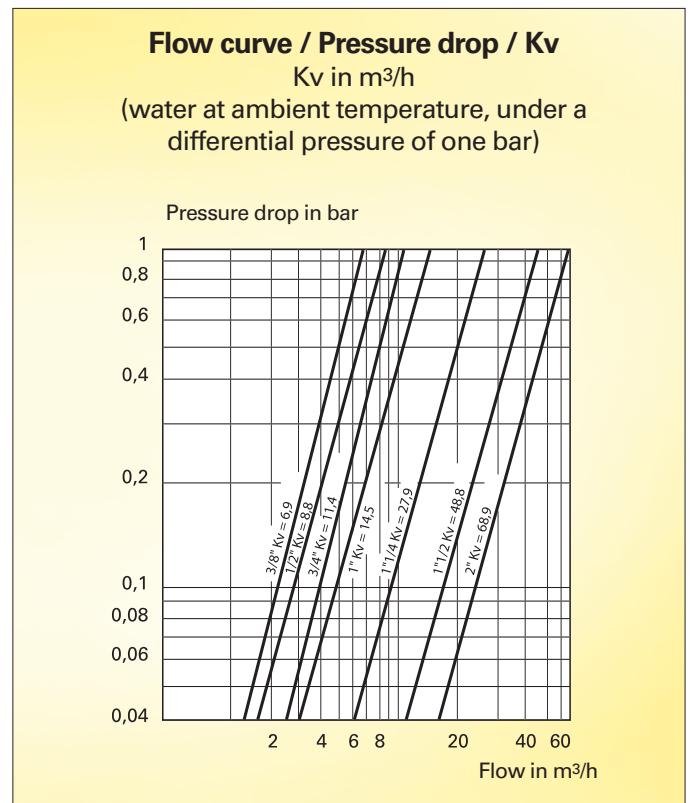

Upon special request, we can supply

- replacement seal kits (all types i.e. FKM, EPDM, Nitrile)
- axial valves equipped with magnetic sensors to indicate their state (open and/or closed)
- chemically nickel-plated axial valves

Please, do not hesitate to consult us.