

ALIMENTATORE VIBRANTE

VIBRATING FEEDER

ALIMENTATOARE VIBRANTE

MOD. AV



Gli alimentatori vibranti vengono impiegati per estrarre il materiale inerte da tramogge e da tunnel posti sottocumuli. Essi sono costituiti da un canale vibrante ove vengono trasmesse vibrazioni tramite motovibratori a masse eccentriche regolabili provocando un avanzamento del materiale continuo e dosato per l'alimentazione di qualsiasi tipo di macchina. L'alimentatore vibrante è costituito da una parte fissa applicabile alle tramogge di alimentazione o ai tunnel e da una parte vibrante a forma di canale. Le due parti sono collegate attraverso delle molle che permettono la vibrazione generata dai motovibratori.



The Vibrating Feeder is employed for the extraction of aggregates from hoppers and tunnels located under-heaps. They consist of a vibrating channel where the vibrations, transmitted by a vibration motor with adjustable eccentric weights, move forward materials evenly and continuously for the feeding of any kind of machine. The vibrating feeder consists of a fixed part that can be attached to the feeding hoppers or tunnels, and of a channel-shaped vibrating part. These two parts are connected by springs which enable the vibration generated by the vibration motors.



Alimentatoarele vibrante sunt folosite pentru preluarea materialului de sub buncar sau tunel facut sub gramada de sort. Sunt construite dintr-un canal vibrator, vibratile sunt transmise de un motor vibrator cu greutatea excetrica reglabila provocand scurgerea materialului dozat pentru alimentarea oricarui tip de utilaj. Alimentatorul vibrant este construit din o parte fixa montata sub buncarul de alimentare sau tunel si o parte vibratoare avand o forma de canal. Cele doua parti sunt conectate prin arcuri care permit vibratile transmise de cele doua motoare vibratoare.

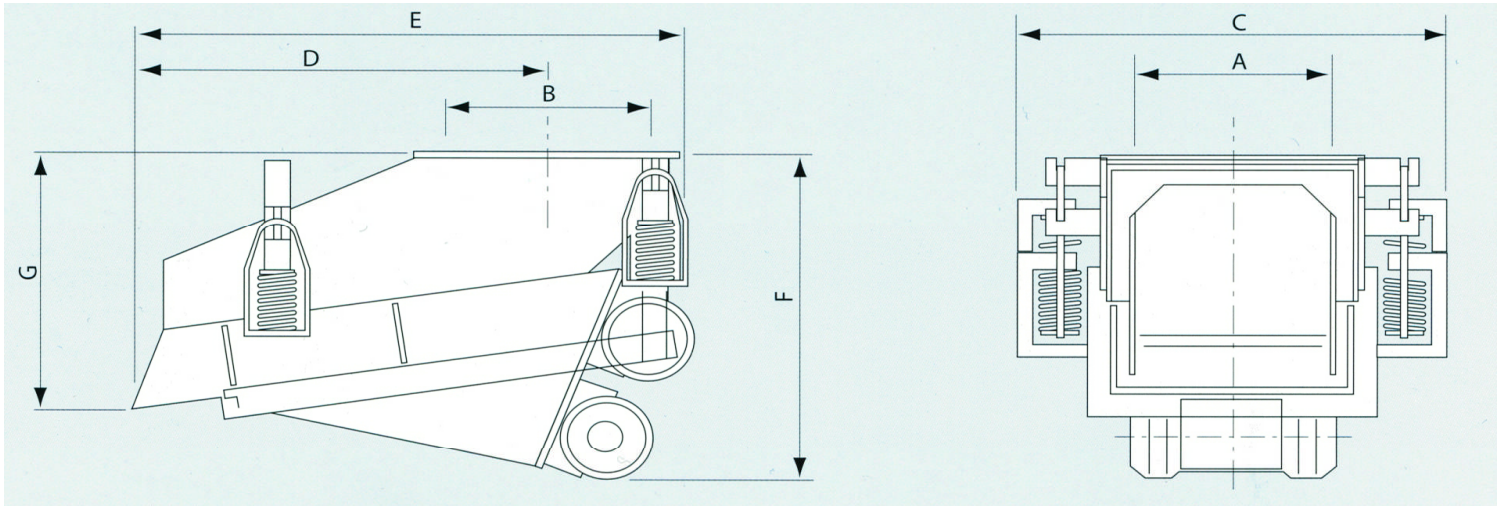

DIMENSIONI E CARATTERISTICHE TECNICHE - DIMENSIONS AND TECHNICAL FEATURES - DIMENSIUNI SI CARACTERISTICHE TEHNICE

MODELLO MODEL MODELUL	DIMENSIONI - DIMENSIONS - DIMENSIUNI (mm.)							Portata Oraria Hourly flow rate Productie/ora mc/h	Pezatura Piece size Marimea (max) mm.	Potenza Inst. Power Inst. Putere Inst. kW	Peso Weight Greutatea Kg.
	A	B	C	D	E	F	G				
AV 90x50	400	400	870	810	1080	690	550	20 - 50	100	0,525+0,525	325
AV 110x65	550	550	1020	950	1310	750	580	40 - 100	150	0,90+0,90	550
AV 130x75	650	650	1080	1050	1460	850	620	40 - 120	200	1,1+1,1	600



SERRAGLIO GIORGIO S.A.S.

33098 Via Grava, 25 ARZENE (PN)
Tel. +39 (0) 434 899489 Fax +39 (0) 434 899637
e-mail: serraglio@serraggiogiorgiosas.it
<http://www.serraggiogiorgiosas.it>

Agente di zona/Area agent/Agente de zona