

Type IL

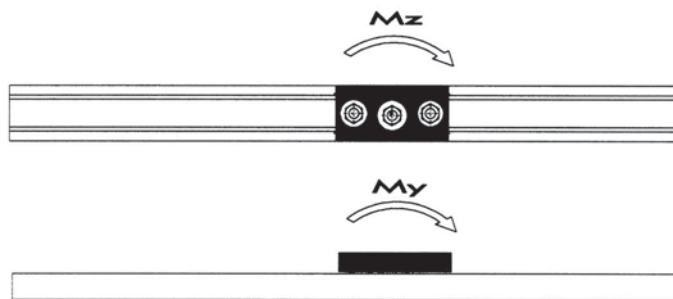

Composants			Charges Limites - N		Moments statiques - Nm		
Rails	Chariot équipé de galets	Galets	Fr	Fa	My	Mz	Mx
IL32	C32	RPE17/RPC17	980,0	330	5,2	9	3
IL42	C42	RPE24/RPC24	1680	500	14,5	25	7,5
IL65	C65	RPE35/RPC35	3930	1160	44	76	25,5

Type RPC et RPE

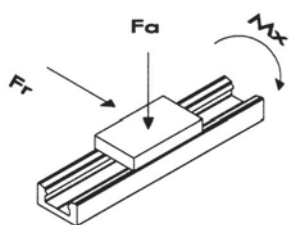
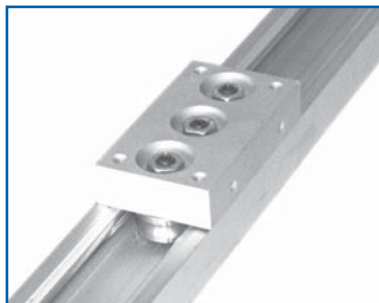
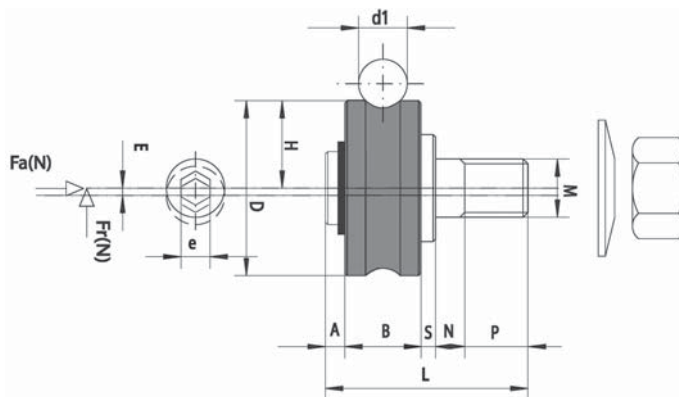

Galets	Dimensions mm												Charges - Basic Load - N		Poids chariot g
	A	B	S	N	P	L	M	H	D	E	e	d1	Axial Fa	Radial Fr	
RPC17	1,5	7	1,5	5	5,5	23	5	10,5	17		2,5	6	250	520	150
RPE17	1,5	7	1,5	5	5,5	23	5	10,5	17	0,5	2,5	6	250	520	150
RPC24	3	11	2	6	7	29	8	14	24		4	6	820	1 590	300
RPE24	3	11	2	6	7	29	8	14	24	0,5	4	6	820	1 590	300
RPC35	3,2	15,9	2	10	13	44	10	20,65	35		5	10	1 090	2 390	800
RPE35	3,2	15,9	2	10	13	44	10	20,65	35	0,75	5	10	1 090	2 390	800

RAIL DE GUIDAGE IL

