



RPC*-*T3

PRESSURE AND TEMPERATURE COMPENSATED THREE-WAY FLOW CONTROL VALVES

SUBPLATE MOUNTING

RPC-2T3 ISO 6263-06

RPC-3T3 ISO 6263-07

HYDRAULIC SYMBOLS

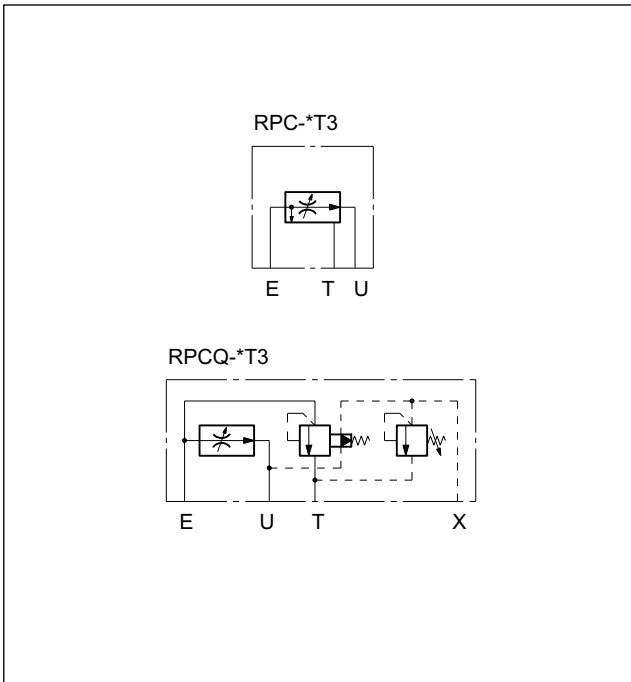

OPERATING PRINCIPLE

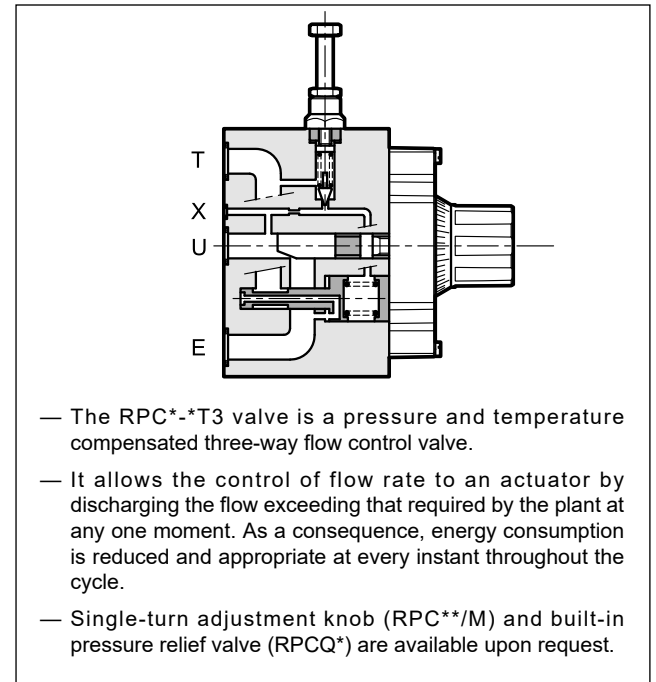

PERFORMANCE RATINGS

(obtained with mineral oil with viscosity of 36 cSt at 50°C)

		RPC*-2T3	RPC*-3T3
Maximum operating pressure	bar	320	250
Minimum pressure difference between E and U		10	12
Maximum controlled flow rate	l/min	50	150
Minimum controlled flow rate		0,060	0,130
Ambient temperature range	°C	-20 / +60	
Fluid temperature range	°C	-20 / +80	
Fluid viscosity range	cSt	10 ÷ 400	
Fluid contamination degree		According to ISO 4406:1999 class 20/18/15	
Fluid contamination degree for flow rate <0,5 l/min		According to ISO 4406:1999 class 18/16/13	
Recommended viscosity	cSt	25	
Mass	kg	4,7	9

1 - IDENTIFICATION CODE

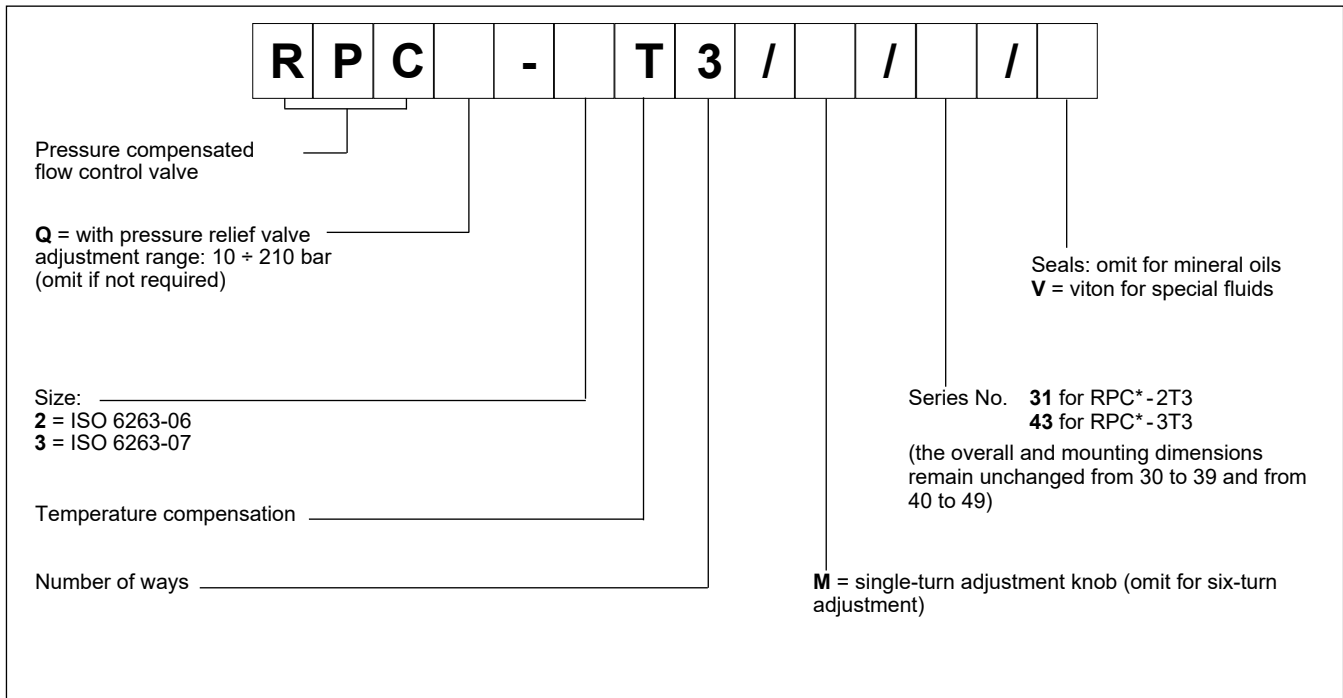

2 - CHARACTERISTIC CURVES

(values obtained with viscosity of 36 cSt at 50°C)

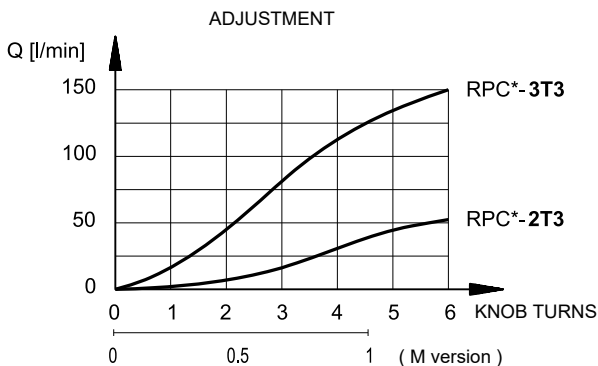

3 - HYDRAULIC FLUIDS

Use mineral oil-based hydraulic fluids HL or HM type, according to ISO 6743-4. For these fluids, use NBR seals. For fluids HFDR type (phosphate esters) use FPM seals (code V). For the use of other kinds of fluid such as HFA, HFB, HFC, please consult our technical department.

Using fluids at temperatures higher than 80 °C causes a faster degradation of the fluid and of the seals characteristics.

The fluid must be preserved in its physical and chemical characteristics.

4 - PRESSURE COMPENSATION

Two throttles in series are in the valve. The first is an opening regulated by the knob; the second, piloted by the pressure upstream and downstream of the first throttle, assures a constant pressure drop across the adjustable throttle. In these conditions, the set flow rate value stays constant within a tolerance range of ±3% of the maximum flow controlled by the valve for maximum pressure variation between the intake and outlet chambers of the valve.

5 - TEMPERATURE COMPENSATION

A device located on the first throttle which is sensitive to the temperature fluctuations corrects the position keeping the controlled flow more or less unaltered even should the oil viscosity change.

The fluctuation of the set flow rate stays within ±2,5% of the maximum flow controlled by the valve.

6 - RPC*-2T3 SERIES 31 OVERALL AND MOUNTING DIMENSIONS

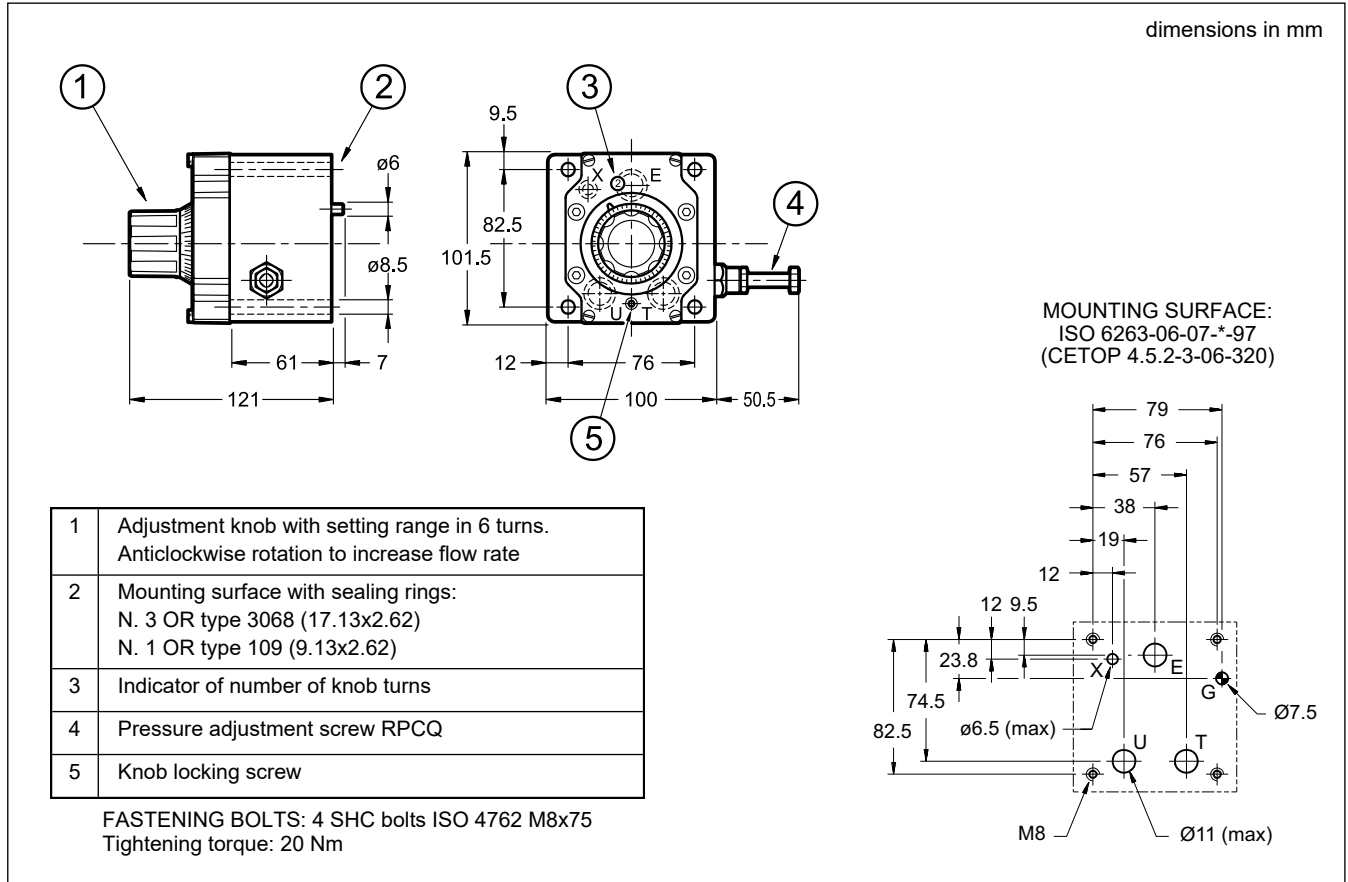

7 - RPC*-3T3 SERIES 43 OVERALL AND MOUNTING DIMENSIONS

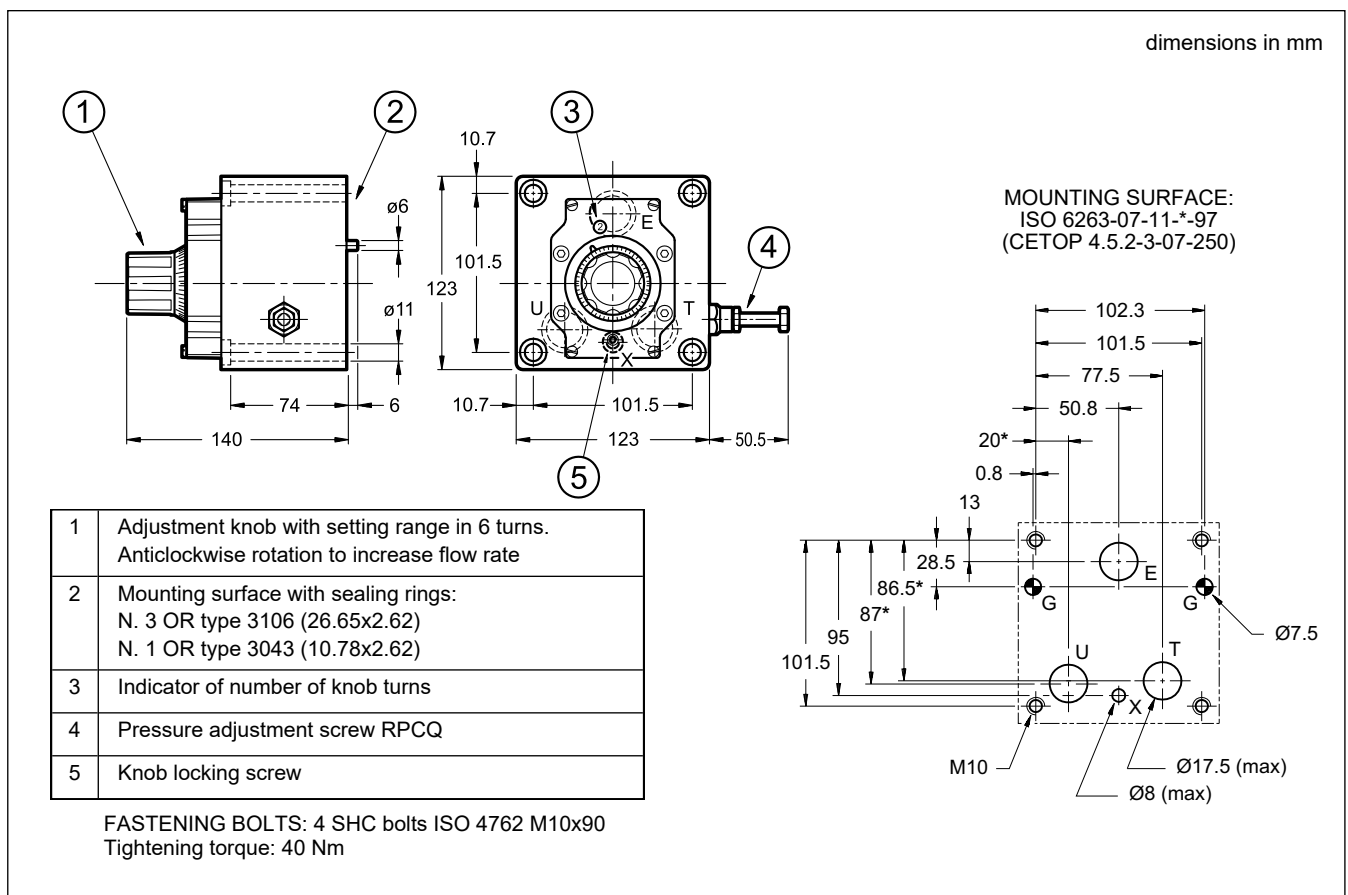

11 - APPLICATION EXAMPLES

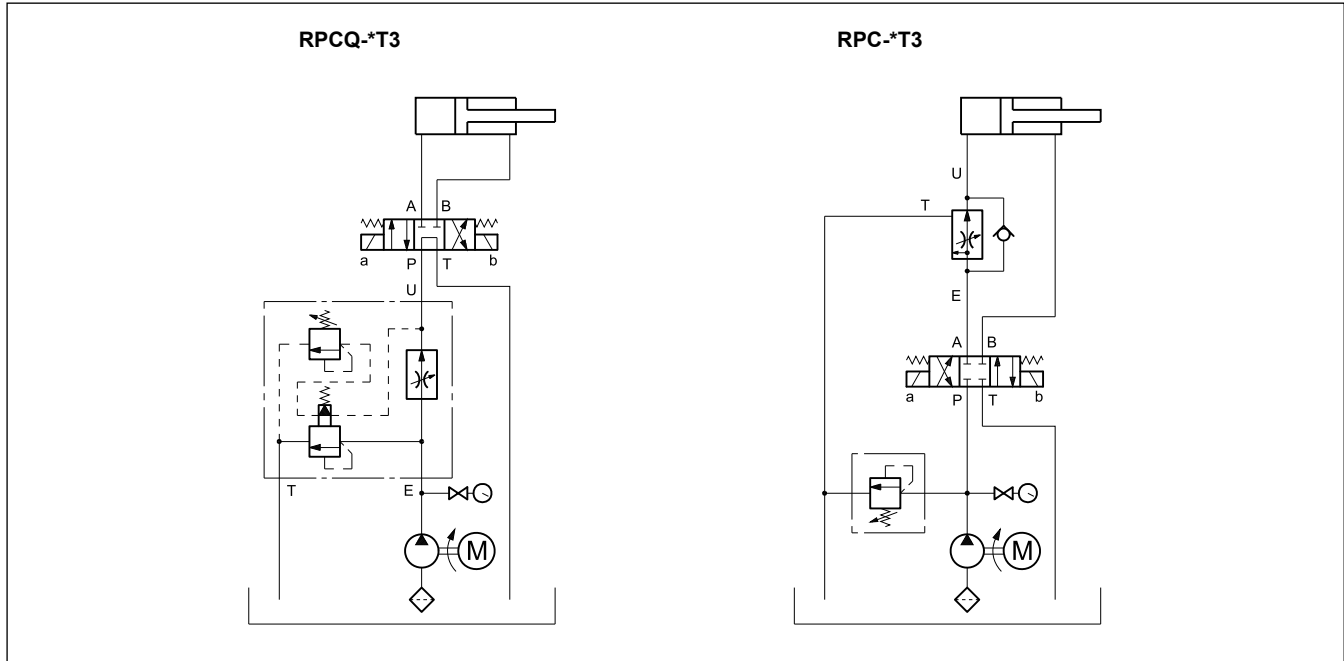

12 - SUBPLATES

(see catalogue 51 000)

	RPC* - 2T3	RPC* - 3T3
Type	PMRPCQ2-AI4G rear ports	PMRPCQ3-AI6G rear ports
E, U, T port dimensions	1/2" BSP	1" BSP
X port dimensions	1/4" BSP	1/4" BSP