



VERSAFLOW MAG 4000 Quick Start

Electromagnetic flow sensor

The documentation is only complete when used in combination with the relevant documentation for the signal converter.

Honeywell

1	Safety instructions	4
<hr/>		
2	Installation	6
<hr/>		
2.1	Scope of delivery.....	6
2.2	Device description	7
2.3	Nameplate	7
2.4	Storage	8
2.5	Transport	8
2.6	Pre-installation requirements	8
2.7	General requirements	9
2.7.1	Vibration	9
2.7.2	Magnetic field.....	9
2.8	Installation conditions	10
2.8.1	Inlet and outlet	10
2.8.2	Bends in 2 or 3 dimensions.....	10
2.8.3	T-section	10
2.8.4	Bends	11
2.8.5	Open feed or discharge	11
2.8.6	Flange deviation	11
2.8.7	Pump	12
2.8.8	Control valve	12
2.8.9	Air venting and vacuum forces	12
2.8.10	Mounting position.....	14
2.9	Mounting	14
2.9.1	Torques and pressures	14
2.9.2	Temperatures	17
<hr/>		
3	Electrical connections	18
<hr/>		
3.1	Safety instructions.....	18
3.2	Grounding	18
3.3	Virtual reference for TWM 9000 (C, W and F version).....	20
3.4	Connection diagrams	20
<hr/>		
4	Technical data	22
<hr/>		
4.1	Dimensions and weights	22
4.2	Vacuum load	25
<hr/>		
5	Technical data	27
<hr/>		

Warnings and symbols used**DANGER!**

This information refers to the immediate danger when working with electricity.

**DANGER!**

These warnings must be observed without fail. Even partial disregard of this warning can lead to serious health problems and even death. There is also the risk of seriously damaging the device or parts of the operator's plant.

**WARNING!**

Disregarding this safety warning, even if only in part, poses the risk of serious health problems. There is also the risk of damaging the device or parts of the operator's plant.

**CAUTION!**

Disregarding these instructions can result in damage to the device or to parts of the operator's plant.

**INFORMATION!**

These instructions contain important information for the handling of the device.

**HANDLING**

- This symbol designates all instructions for actions to be carried out by the operator in the specified sequence.

RESULT

This symbol refers to all important consequences of the previous actions.

Safety instructions for the operator**CAUTION!**

Installation, assembly, start-up and maintenance may only be performed by appropriately trained personnel. The regional occupational health and safety directives must always be observed.

**LEGAL NOTICE!**

The responsibility as to the suitability and intended use of this device rests solely with the user. The supplier assumes no responsibility in the event of improper use by the customer. Improper installation and operation may lead to loss of warranty. In addition, the "Terms and Conditions of Sale" apply which form the basis of the purchase contract.

**INFORMATION!**

- *Further information can be found on the supplied CD-ROM in the manual, on the data sheet, in special manuals, certificates and on the manufacturer's website.*
- *If you need to return the device to the manufacturer or supplier, please fill out the form contained on the CD-ROM and send it with the device. Unfortunately, the manufacturer cannot repair or inspect the device without the completed form.*

2.1 Scope of delivery



INFORMATION!

Do a check of the packing list to make sure that you have all the elements given in the order.



INFORMATION!

Inspect the packaging carefully for damages or signs of rough handling. Report damage to the carrier and to the local office of the manufacturer.



INFORMATION!

The remote version will arrive in two cartons. One carton contains the converter and one carton contains the sensor.

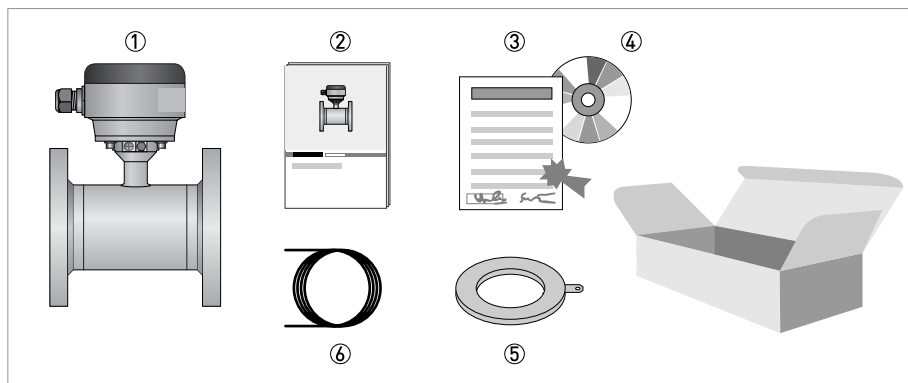

Figure 2-1: Scope of delivery

- ① Ordered flowmeter
- ② Product documentation
- ③ Factory calibration report
- ④ CD-ROM with product documentation in available languages
- ⑤ Grounding rings (optional)
- ⑥ Signal cable (remote versions only)



INFORMATION!

Assembly materials and tools are not part of the delivery. Use the assembly materials and tools in compliance with the applicable occupational health and safety directives.

2.2 Device description

Your measuring device is supplied ready for operation. The factory settings for the operating data have been made in accordance with your order specifications.

The following versions are available:

- Compact version (the signal converter is mounted directly on the measuring sensor)
- Remote version (electrical connection to the measuring sensor via field current and signal cable)

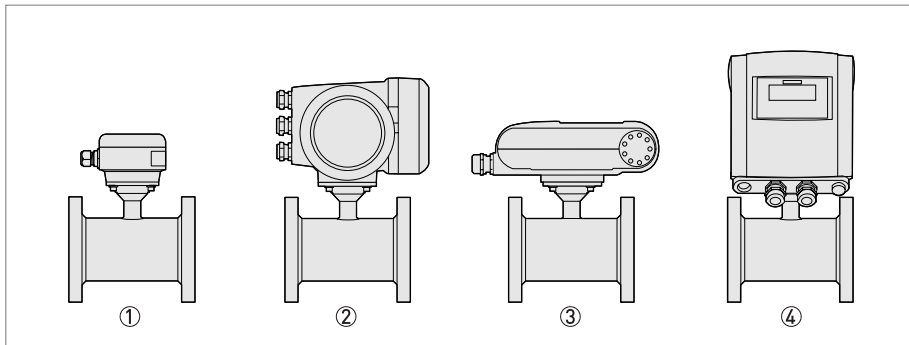

Figure 2-2: Device versions

- ① Remote version
- ② Compact version with TWM 9000 signal converter
- ③ Compact version with TWM 1000 (0°) signal converter
- ④ Compact version with TWM 1000 (45°) signal converter

2.3 Nameplate



INFORMATION!

Check the device nameplate to ensure that the device is delivered according to your order. Additional information (a.o correct supply voltage), can be found in the documentation of the signal converter.

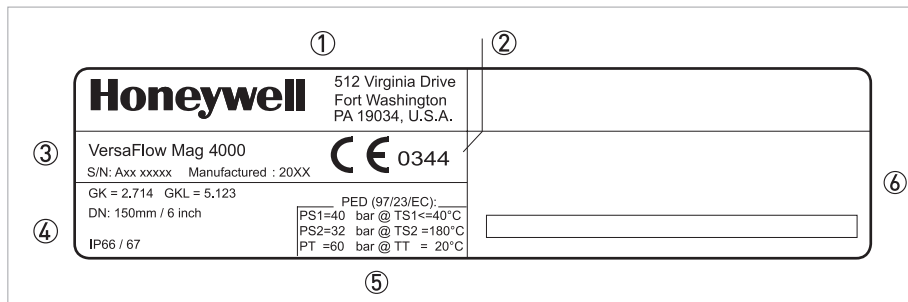

- ① Name and address of the manufacturer
- ② CE sign with number(s) of notified body / bodies
- ③ Type designation of the flowmeter and manufacturer date
- ④ Calibration data
- ⑤ PED data
- ⑥ Tag nr and approvals related information

2.7 General requirements



INFORMATION!

The following precautions must be taken to ensure reliable installation.

- Make sure that there is adequate space to the sides.
- Protect the signal converter from direct sunlight and install a sun shade if necessary.
- Signal converters installed in control cabinets require adequate cooling, e.g. by fan or heat exchanger.
- Do not expose the signal converter to intense vibration. The flowmeters are tested for a vibration level in accordance with IEC 68-2-64.

2.7.1 Vibration

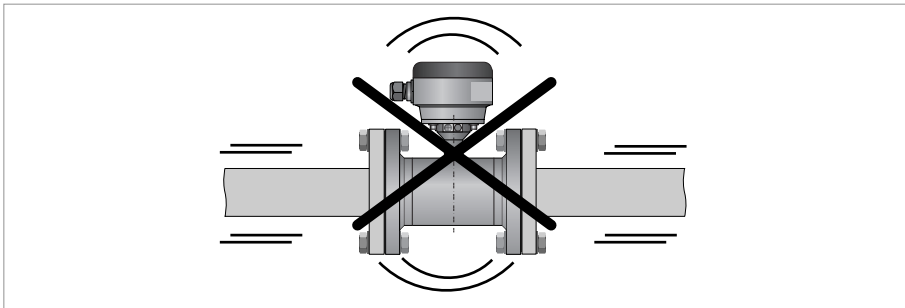

Figure 2-4: Avoid vibrations

2.7.2 Magnetic field

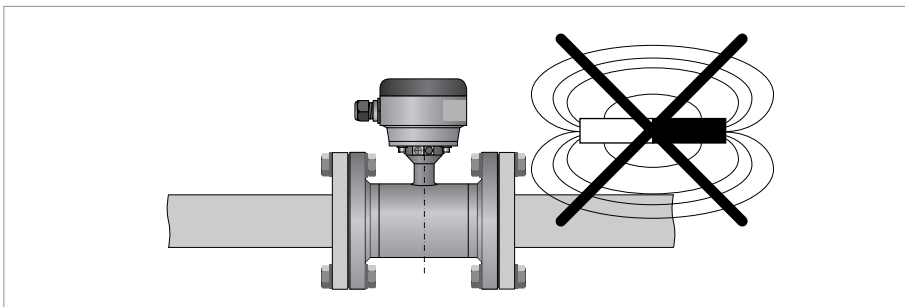

Figure 2-5: Avoid magnetic fields

2.8 Installation conditions

2.8.1 Inlet and outlet

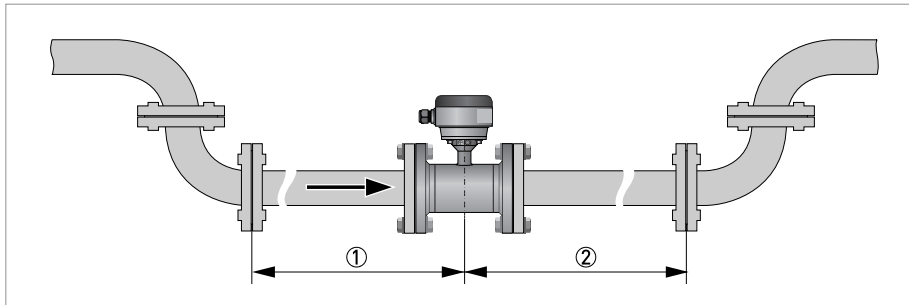

Figure 2-6: Recommended inlet and outlet

- ① Refer to chapter "Bends in 2 or 3 dimensions"
- ② ≥ 2 DN



INFORMATION!

Sensors of type VN02 up to DN10:

The inlet and outlet sections are enclosed inside the sensor.

2.8.2 Bends in 2 or 3 dimensions

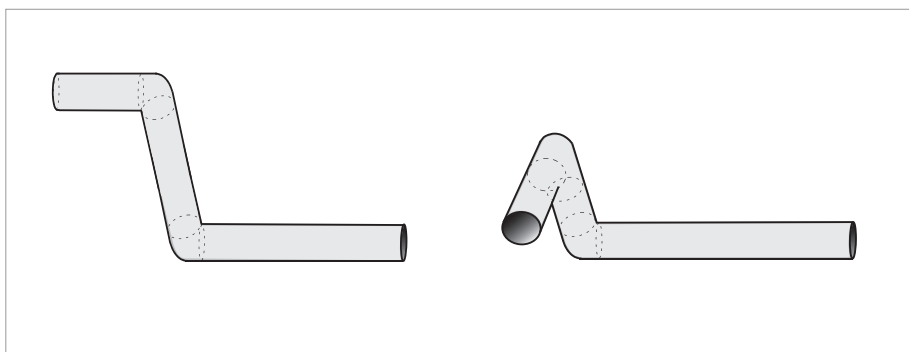

Figure 2-7: 2 and 3 dimensional bends, in front of flowmeter

- ① Bends in 2 dimensions: ≥ 5 DN; bends in 3 dimensions: ≥ 10 DN

2.8.3 T-section

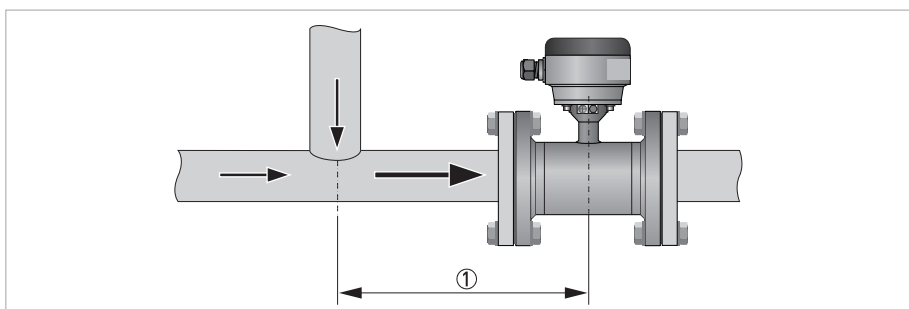

Figure 2-8: Distance behind a T-section

- ① ≥ 10 DN

2.8.4 Bends



CAUTION!
 Avoid draining or partial filling of the flow sensor

2.8.5 Open feed or discharge

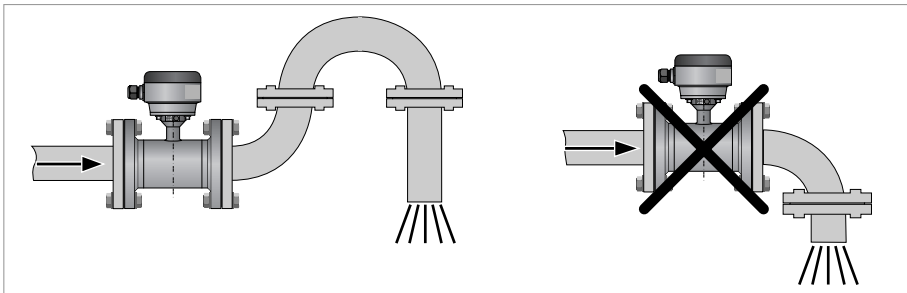

Figure 2-9: Installation in front of an open discharge

2.8.6 Flange deviation



CAUTION!
 Max. permissible deviation of pipe flange faces:
 $L_{max} - L_{min} \leq 0.5 \text{ mm} / 0.02''$

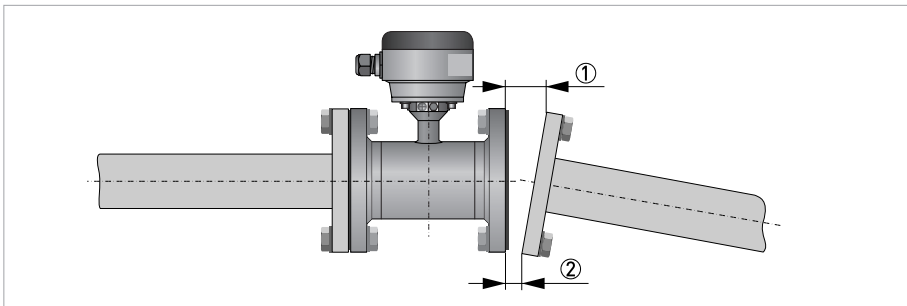

Figure 2-10: Flange deviation

- ① L_{max}
- ② L_{min}

2.8.7 Pump

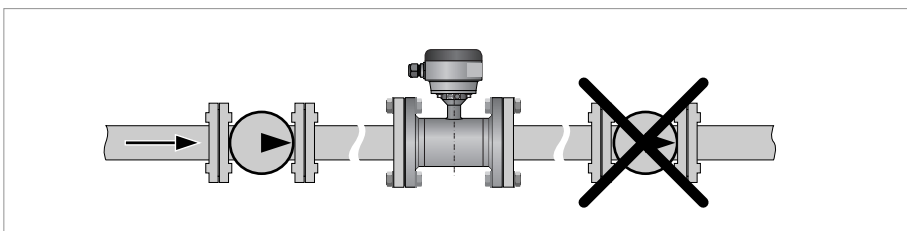

Figure 2-11: Installation behind a pump

2.8.8 Control valve

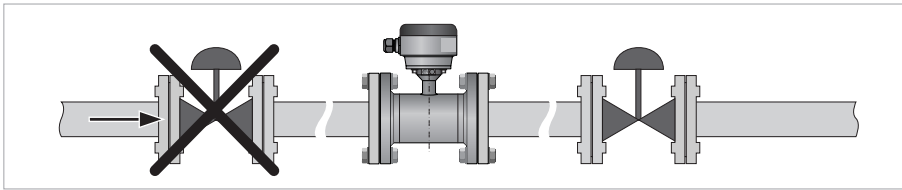

Figure 2-12: Installation in front of a control valve

2.8.9 Air venting and vacuum forces

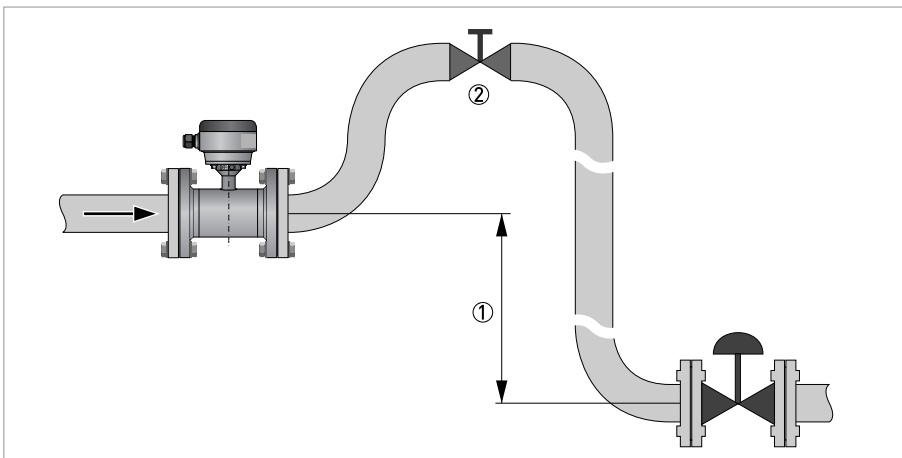

Figure 2-13: Air venting

- ① ≥ 5 m
- ② Air ventilation point

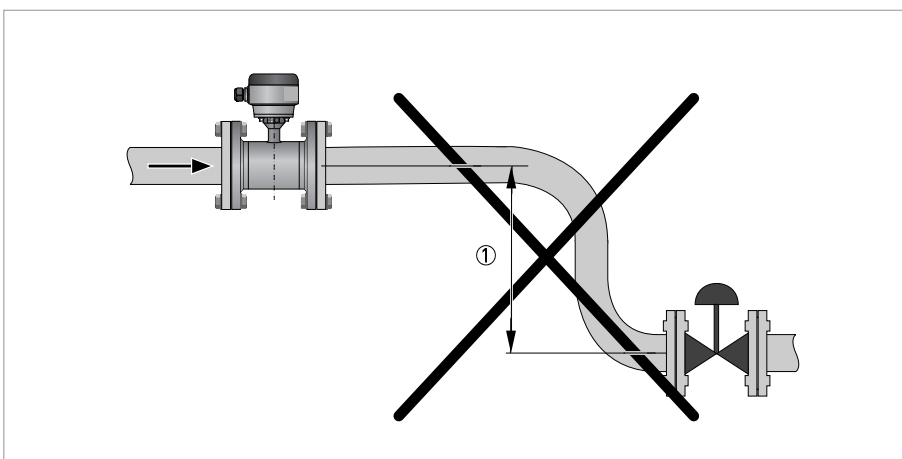

Figure 2-14: Vacuum

- ① ≥ 5 m

2.8.10 Mounting position

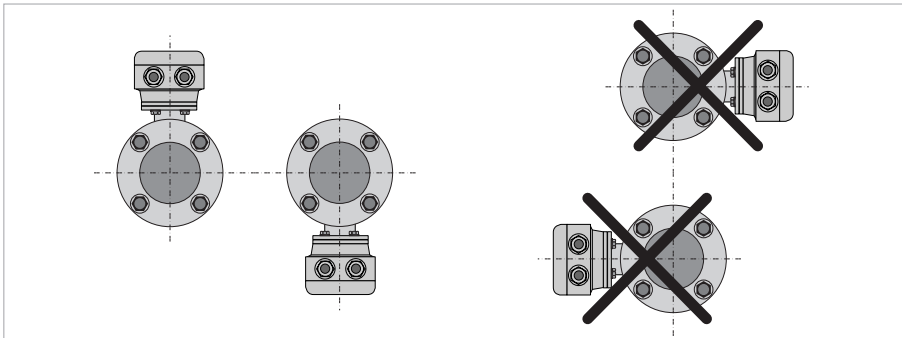

Figure 2-15: Mounting position

2.9 Mounting

2.9.1 Torques and pressures

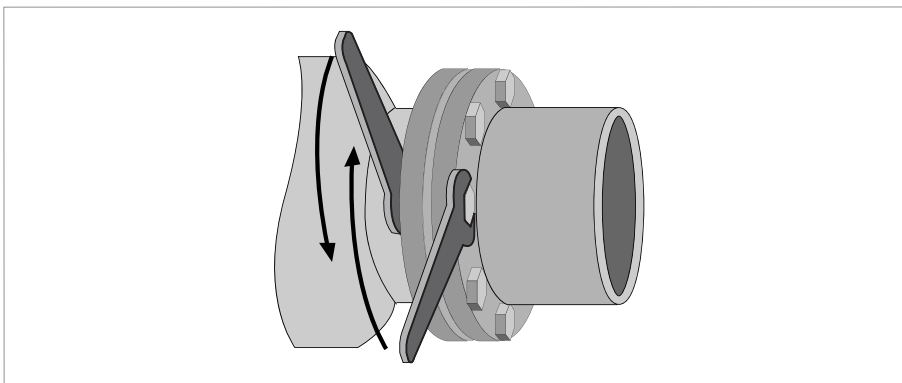

Figure 2-16: Tightening of bolts



Tightening of bolts

- Always tighten the bolts uniformly and in diagonally opposite sequence.
- Do not exceed the maximum torque value.
- Step 1: Apply approx. 50% of max. torque given in table.
- Step 2: Apply approx. 80% of max. torque given in table.
- Step 3: Apply 100% of max. torque given in table.



INFORMATION!

Other sizes / pressure ratings on request.

Nominal size DN [mm]	Pressure rating	Bolts ②	Max. torque [Nm] ①				
			PFA	PTFE	ETFE	PU	Hard rubber
2.5	PN 40	4 x M 12	32	32	-	-	-
4	PN 40	4 x M 12	32	32	-	-	-
6	PN 40	4 x M 12	32	32	-	-	-
10	PN 40	4 x M 12	7.6	7.6	-	4.6	-
15	PN 40	4 x M 12	9.3	9.3	-	5.7	-
20	PN 40	4 x M 12	16	16	-	9.6	-
25	PN 40	4 x M 12	22	22	22	11	-
32	PN 40	4 x M 16	37	37	37	19	-
40	PN 40	4 x M 16	43	43	43	25	-
50	PN 40	4 x M 16	55	55	55	31	-
65	PN 16	4 x M 16	51	51	51	42	-
65	PN 40	8 x M 16	38	38	38	21	-
80	PN 40	8 x M 16	47	47	47	25	-
100	PN 16	8 x M 16	39	39	39	30	-
125	PN 16	8 x M 16	53	53	53	40	-
150	PN 16	8 x M 20	68	68	68	47	-
200	PN 10	8 x M 20	84	84	84	68	68
200	PN 16	12 x M 20	68	68	68	45	45
250	PN 10	12 x M 20	78	78	78	65	65
250	PN 16	12 x M 24	116	116	116	78	78
300	PN 10	12 x M 20	88	88	88	76	76
300	PN 16	12 x M 24	144	144	144	105	105
350	PN 10	16 x M 20	97	97	97	75	75
400	PN 10	16 x M 24	139	139	139	104	104
450	PN 10	20 x M 24	-	127	127	93	93
500	PN 10	20 x M 24	-	149	149	107	107
600	PN 10	20 x M 27	-	205	205	138	138
700	PN 10	20 x M 27	-	238	238	163	163
800	PN 10	24 x M 30	-	328	328	219	219
900	PN 10	28 x M 30	-	308	308	205	205
1000	PN 10	28 x M 35	-	392	392	261	261
③ *							

① The specified torque values are dependent on variables (temperature, bolt material, gasket material, lubricants, etc.) which are not within the control of the manufacturer. Therefore the values should be regarded as indicative only.

② F= ASTM gr B7 Studbolts - F=0.14 - Carbon steel flanges

③ * Information DN > 1000; please contact the support service department

Nominal size [inch]	Flange class [lb]	Bolts ②	Max. torque [in-lb] ①				
			PFA	PTFE	ETFE	PU	Hard rubber
1/10	150	4 x 1/2"	39	39	-	-	-
1/6	150	4 x 1/2"	39	39	-	-	-
1/4	150	4 x 1/2"	39	39	-	-	-
3/8	150	4 x 1/2"	39	39	-	-	-
1/2	150	4 x 1/2"	34	34	-	-	-
3/4	150	4 x 1/2"	50	50	-	-	-
1	150	4 x 1/2"	67	67	67	-	-
1 1/4	150	4 x 1/2"	97	97	97	-	-
1 1/2	150	4 x 1/2"	138	138	138	-	-
2	150	4 x 5/8"	225	225	225	-	-
3	150	4 x 5/8"	43	43	43	-	-
4	150	8 x 5/8"	34	34	34	-	-
6	150	8 x 3/4"	61	61	61	-	-
8	150	8 x 3/4"	979	979	979	818	818
10	150	12 x 7/8"	1104	1104	1104	923	923
12	150	12 x 7/8"	1478	1478	1478	1237	1237
14	150	12 x 1"	1835	1835	1835	1538	1538
16	150	16 x 1"	1767	1767	1767	1481	1481
18	150	16 x 1 1/8"	-	2605	2605	2183	2183
20	150	20 x 1 1/8"	-	2365	2365	1984	1984
24	150	20 x 1 1/4"	-	3419	3419	2873	2873
28	150	28 x 1 1/4"	-	2904	2904	-	③ *
32	150	28 x 1 1/2"	-	4560	4560	-	*
36	150	32 x 1 1/2"	-	-	③ *	-	*
40	150	36 x 1 1/2"	-	-	*	-	*

① The specified torque values are dependent on variables (temperature, bolt material, gasket material, lubricants, etc.) which are not within the control of the manufacturer. Therefore the values should be regarded as indicative only.

② F= ASTM gr B7 Studbolts - F=0.14 - Carbon steel flanges

③ Information * ; please contact the support service department



INFORMATION!

Other sizes / pressure ratings on request.



CAUTION!

- Pressures are applicable at 20° C / 68° F.
- For higher temperatures, the pressure ratings are as per ASME B16.5.

2.9.2 Temperatures



CAUTION!
Protect the device from direct sunlight.

Temperature range	Process [°C]		Ambient [°C]		Process [°F]		Ambient [°F]	
	min.	max.	min.	max.	min.	max.	min.	max.

PTFE & PFA

Separate flow sensor	-40	180	-40	65	-40	356	-40	149
Compact with TWM 9000	-40	140	-40	65	-40	284	-40	149
Compact with TWM 1000	-40	120	-40	65	-40	284	-40	149

ETFE

Separate flow sensor	-40	120	-40	65	-40	248	-40	149
Compact with TWM 9000	-40	120	-40	65	-40	248	-40	149
Compact with TWM 1000	-40	120	-40	65	-40	248	-40	149

Hard rubber

Separate flow sensor ①	-5	80	-40	65	23	176	-40	149
Compact with TWM 9000 ①	-5	80	-40	65	23	176	-40	149
Compact with TWM 1000 ①	-5	80	-40	65	23	176	-40	149

PU

Separate flow sensor	-5	65	-40	65	23	149	-40	149
Compact with TWM 9000	-5	65	-40	65	23	149	-40	149
Compact with TWM 1000	-5	65	-40	65	23	149	-40	149

① Hard rubber liner is available for Ex-versions only.

3.1 Safety instructions



DANGER!

All work on the electrical connections may only be carried out with the power disconnected. Take note of the voltage data on the nameplate!



DANGER!

Observe the national regulations for electrical installations!



DANGER!

For devices used in hazardous areas, additional safety notes apply; please refer to the Ex documentation.



WARNING!

Observe without fail the local occupational health and safety regulations. Any work done on the electrical components of the measuring device may only be carried out by properly trained specialists.



INFORMATION!

Look at the device nameplate to ensure that the device is delivered according to your order. Check for the correct supply voltage printed on the nameplate.

3.2 Grounding



DANGER!

The device must be grounded in accordance with regulations in order to protect personnel against electric shocks.

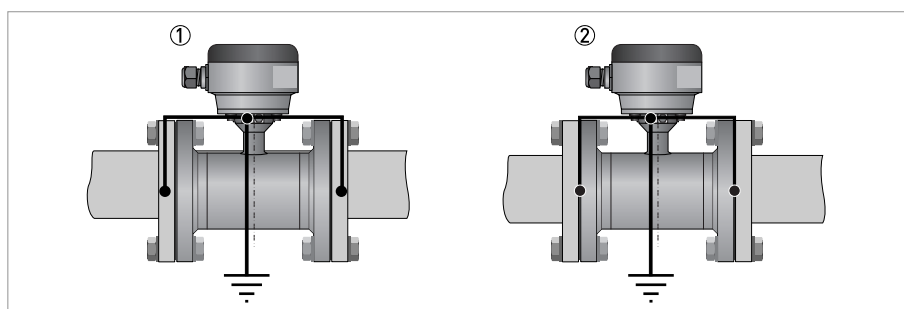

Figure 3-1: Grounding

- ① Metal pipelines, not internally coated. Grounding without grounding rings.
- ② Metal pipelines with internal coating and non-conductive pipelining. Grounding with grounding rings.

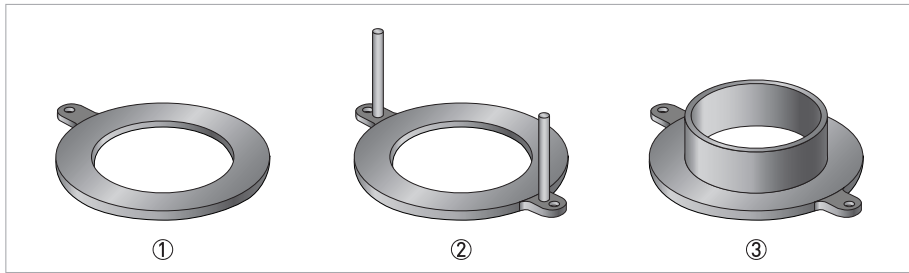

Figure 3-2: Different types of grounding rings

- ① Grounding ring number 1
- ② Grounding ring number 2
- ③ Grounding ring number 3

Grounding ring number 1:

- 3 mm / 0.1" thick (tantalum: 0.5 mm / 0.02")

Grounding ring number 2:

- 3 mm / 0.1" thick
- Prevents damage to the flanges during transport and installation
- Especially for flow sensors with PTFE liner

Grounding ring number 3:

- 3 mm / 0.1" thick
- With cylindrical neck (length 30 mm / 1.25" for DN10...150 / 3/8...6")
- Prevents damage to the liner when abrasive liquids are used

3.3 Virtual reference for TWM 9000 (C, W and F version)

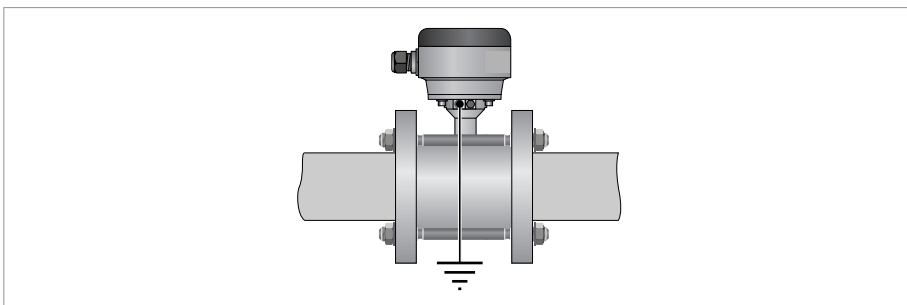

Figure 3-3: Virtual reference

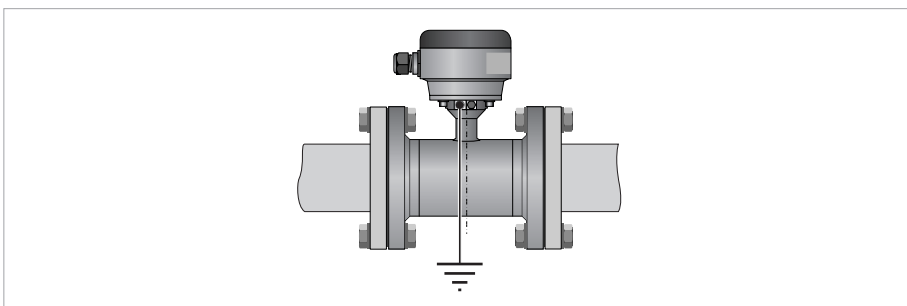

Figure 3-4: Virtual reference

Minimum requirements:

- Size: \geq DN10
- Electrical conductivity: \geq 200 μ S/cm
- Electrode cable: max. 50 m / 164 ft, type DS

3.4 Connection diagrams



INFORMATION!

For the connection diagrams please refer to the documentation of the applicable signal converter.

4.1 Dimensions and weights

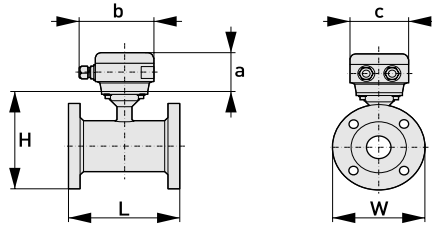
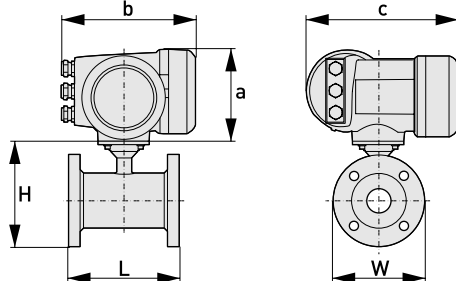
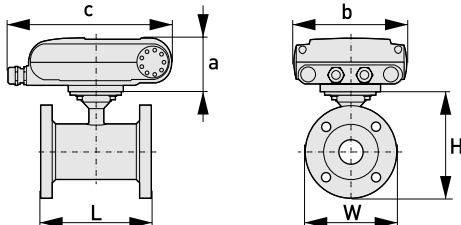
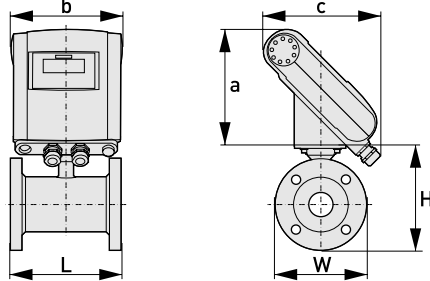
<p>Remote version</p>		<p>a = 88 mm / 3.5"</p> <p>b = 139 mm / 5.5" ①</p> <p>c = 106 mm / 4.2"</p> <p>Total height = H + a</p>
<p>Compact version with TWM 9000</p>		<p>a = 155 mm / 6.1"</p> <p>b = 230 mm / 9.1" ①</p> <p>c = 260 mm / 10.2"</p> <p>Total height = H + a</p>
<p>Compact version with TWM 1000 (0°)</p>		<p>a = 82 mm / 3.2"</p> <p>b = 161 mm / 6.3"</p> <p>c = 257 mm / 10.1" ①</p> <p>Total height = H + a</p>
<p>Compact version with TWM 1000 (45°)</p>		<p>a = 186 mm / 7.3"</p> <p>b = 161 mm / 6.3"</p> <p>c = 184 mm / 7.3" ①</p> <p>Total height = H + a</p>

① The value may vary depending on the used cable glands.



INFORMATION!

- All data given in the following tables are based on standard versions of the flow sensor only.
- Especially for smaller nominal sizes of the flow sensor, the signal converter can be bigger than the flow sensor.
- Note that for other pressure ratings than mentioned, the dimensions may be different.
- For full information on signal converter dimensions see relevant documentation.

EN 1092-1

Nominal size		Dimensions [mm]				Approx. weight [kg]
DN	PN [bar]	L		H	W	
		DIN	ISO			
2.5...6	40	130	-	142	90	3
10	40	130 ①	-	106	90	6
15	40	130 ①	200	106	95	6
20	40	150	200	158	105	7
25	40	150	200	140	115	4
32	40	150	200	157	140	5
40	40	150	200	166	150	5
50	40	200	200	186	165	9
65	16	200	200	200	185	9
80	40	200	200	209	200	12
100	16	250	250	237	220	15
125	16	250	250	266	250	19
150	16	300	300	300	285	27
200	10	350	350	361	340	34
250	10	400	450	408	395	48
300	10	500	500	458	445	58
350	10	500	550	510	505	78
400	10	600	600	568	565	101
450	10	600	-	618	615	111
500	10	600	-	671	670	130
600	10	600	-	781	780	165
700	10	700	-	898	895	248
800	10	800	-	1012	1015	331
900	10	900	-	1114	1115	430
1000	10	1000	-	1225	1230	507
1200	6	1200	-	1417	1405	555
1400	6	1400	-	1619	1630	765
1600	6	1600	-	1819	1830	1035
1800	6	1800	-	2027	2045	1470
2000	6	2000	-	2259	2265	1860

① 150 mm for construction according to order code MM41(contact sales).

150 lb flanges

Nominal size		Dimensions [inches]			Approx. weight [lb]
ASME	PN [psi]	L	H	W	
1/10"	284	5.12	5.59	3.50	6
1/8"	284	5.12	5.59	3.50	6
1/4"	284	5.12	5.59	3.50	6
3/8"	284	5.12 ①	5.08	3.50	12
1/2"	284	5.12 ①	5.08	3.50	12
3/4"	284	5.91	5.28	3.88	18
1"	284	5.91	5.39	4.25	7
1 1/4"	284	5.91	5.98	4.62	7
1 1/2"	284	5.91	6.10	5.00	11
2"	284	7.87	7.05	5.98	18
2 1/2"	284	7.87	7.72	7.00	24
3"	284	7.87	8.03	7.50	26
4"	284	9.84	9.49	9.00	40
5"	284	9.84	10.55	10.0	49
6"	284	11.81	11.69	11.0	64
8"	284	13.78	14.25	13.5	95
10"	284	15.75	16.3	16.0	143
12"	284	19.69	18.78	19.0	207
14"	284	27.56	20.67	21.0	284
16"	284	31.50	22.95	23.5	364
18"	284	31.50	24.72	25.0	410
20"	284	31.50	26.97	27.5	492
24"	284	31.50	31.38	32.0	675

① 5.91" for construction according to order code MM41(contact sales).

**CAUTION!**

- Pressures at 20°C / 68°F.
- For higher temperatures, the pressure and temperature ratings are as per ASME B16.5.

300 lb flanges

Nominal size		Dimensions [inches]			Approx. weight [lb]
ASME	PN [psi]	L	H	W	
1/10"	741	5.12	5.59	3.75	6
1/8"	741	5.12	5.59	3.75	6
1/4"	741	5.12	5.59	3.75	6
3/8"	741	5.12 ①	5.24	3.75	15
1/2"	741	5.12 ①	5.24	3.75	15
3/4"	741	5.91	5.67	4.62	20
1"	741	5.91	5.71	4.87	11
1 1/2"	741	7.87	6.65	6.13	13
2"	741	9.84	7.32	6.50	22
3"	741	9.84	8.43	8.25	31
4"	741	11.81	10.00	10.0	44
6"	741	13.75	12.44	12.5	73
8"	741	15.75	15.04	15.0	157
10"	741	19.69	17.05	17.5	247
12"	741	23.62	20.00	20.5	375
14"	741	27.56	21.65	23.0	474
16"	741	31.50	23.98	25.5	639
20"	741	31.50	28.46	30.5	937
24"	741	31.50	33.39	36.0	1345

① 5.91" for construction according to order code MM41(contact sales).



CAUTION!

- Pressures at 20°C / 68°F.
- For higher temperatures, the pressure and temperature ratings are as per ASME B16.5.

4.2 Vacuum load

Diameter	Max. pressure	Vacuum load in mbar abs. at a process temperature of								
[mm]	[bar]	40°C	60°C	70°C	80°C	90°C	100°C	120°C	140°C	180°C
Liner in PTFE										
DN10...20	50	0	0	0	0	0	0	500	750	1000
DN200...300	50	500	750	1000	1000	1000	1000	1000	1000	1000
DN350...600	50	800	1000	1000	1000	1000	1000	1000	1000	1000
Liner in PFA										
DN2.5...150	50	0	0	0	0	0	0	0	0	0
Liner in ETFE										
DN200...2000	150	100	100	100	100	100	100	100	-	-
Liner in Hard rubber										
DN200...300	150	250	400	400	400	-	-	-	-	-
DN350...3000	150	500	600	600	600	-	-	-	-	-
Liner in PU										
DN200...1800	1500	500	600	-	-	-	-	-	-	-

Diameter	Max. pressure	Vacuum load in psia at a process temperature of								
[inch]	[psi]	104°F	140°F	158°F	176°F	194°F	212°F	248°F	284°F	356°F
Liner in PTFE										
3/8...3/4"	725	0	0	0	0	0	0	7.3	10.9	14.5
8...12"	725	7.3	10.9	14.5	14.5	14.5	14.5	14.5	14.5	14.5
14...24"	725	11.6	14.5	14.5	14.5	14.5	14.5	14.5	14.5	14.5
Liner in PFA										
1/10...6"	725	0	0	0	0	0	0	0	0	0
Liner in ETFE										
8...72"	2176	1.5	1.5	1.5	1.5	1.5	1.5	1.5	-	-
Liner in Hard rubber										
8...12"	2176	3.6	5.8	5.8	5.8	-	-	-	-	-
14...120"	2176	7.3	8.7	8.7	8.7	-	-	-	-	-
Liner in PU										
8...72"	21756	7.3	8.7	-	-	-	-	-	-	-

Honeywell Process Solutions
1250 W Sam Houston Pkwy S
Houston, TX 77042
www.honeywellprocess.com

© Honeywell International Inc.
Subject to change without notice.