

# Gauge adapters for pressure measuring instruments

## Model 910.14

WIKA data sheet AC 09.05

### Applications

- For the installation of pressure measuring instruments, gauge cocks, shut-off valves, pressure gauge syphons, snubbers and other component accessories.

### Types of adapters

#### Male-female adapters

are used where the size of the male thread is different from the female thread in the parts to be connected.

#### Female-female adapters

are used where both components to be connected have male threads.

#### Male-male adapters

are used where both components to be connected have female threads.

#### Self-sealing nipples (SS)

are used to adapt a smaller size threaded connection to a larger one (e.g. G ¼ to G ½). Due to their design, the nipples are self-sealing (i.e. the taper turned into the nipple presses into the bore of the pressure measuring instrument's pressure channel connection. To protect against inadvertent release of the two threaded parts, they are secured with a special adhesive.

#### LH-RH unions

per DIN 16283 have a right-hand thread on one side, and a left-hand thread on the other, which allow the component to be sealed and orientated into any direction required.

#### Union nuts with nipple

per DIN 16284, enable mounting without having to change the orientation of the parts to be connected against each other.

#### Solderless compression fitting with ferrule

are used to connect pressure measuring instruments or fittings with pipelines from copper, steel and stainless steel. Particularly useful mounting, no solder or weld points. A sealing washer is included in the delivery.

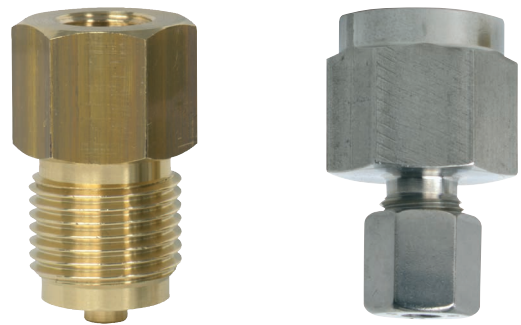

Fig. left: Adapter, male-female, G ½ / G ¼ B

Fig. right: Compression fitting with ferrule, G ½ 400/6

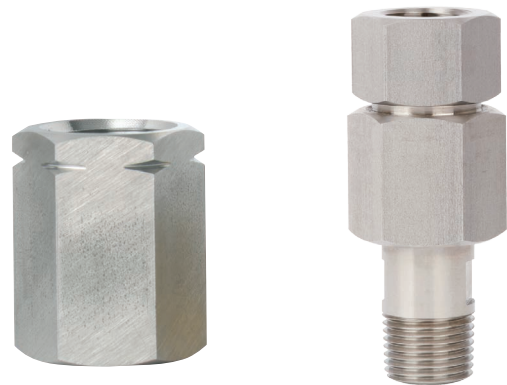

Fig. left: LH-RH union, G ½ / G ½ LH

Fig. right: Rotatable gauge adapter (swivel adapter)

#### Flange set with lens-type sealing ring

is used for the assembly of high pressure measuring instruments (up to 4000 bar). Through the two threaded flanges, which are clamped by four bolts, the pressure measuring instrument can be positioned in any orientation required.

#### Weld-on adapters

with male thread they are used with left-handed threads for connection with LH-RH union, and with right-handed threads (per EN 837-1) they are mainly found with direct pressure port entries.

#### Rotatable gauge adapters (swivel adapters)

enable the orientation of pressure measuring instruments through a 360 ° range.

## Standard version

### Dimensions and connection

see table

### Material

Brass, steel, stainless steel 1.4571

### Options

- Brass, chrome plated
- Special threads

## Dimensions in mm

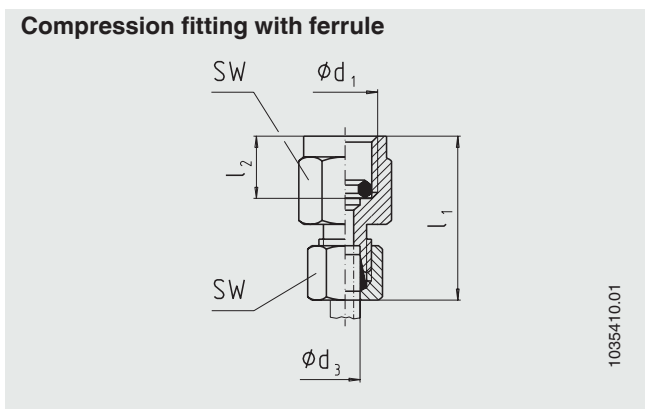
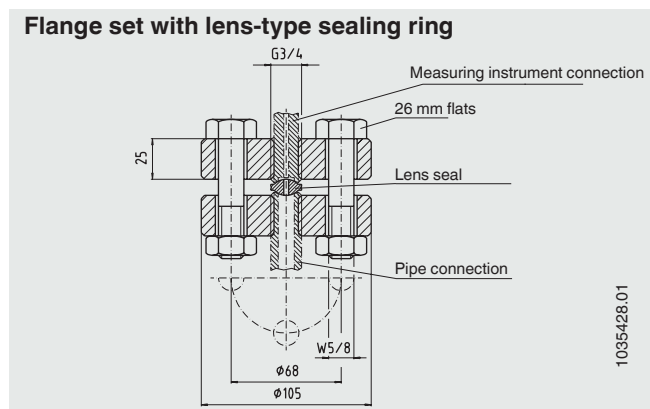
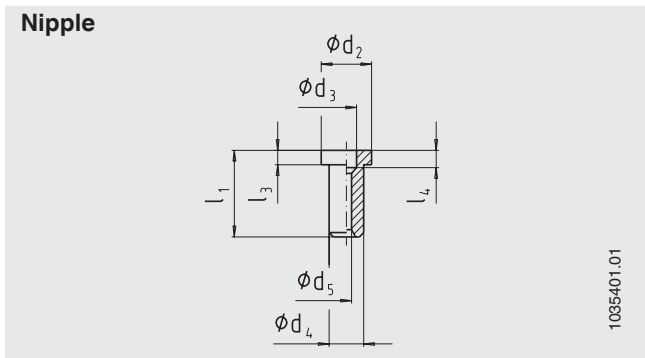
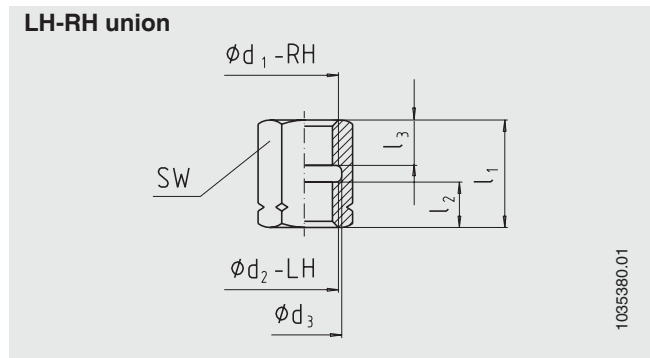
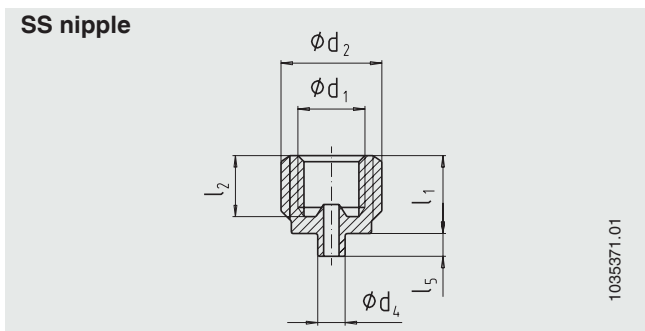
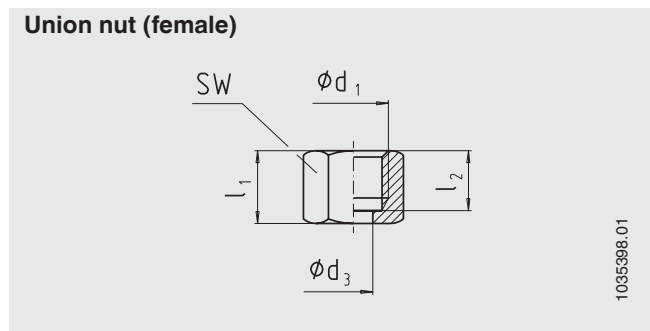
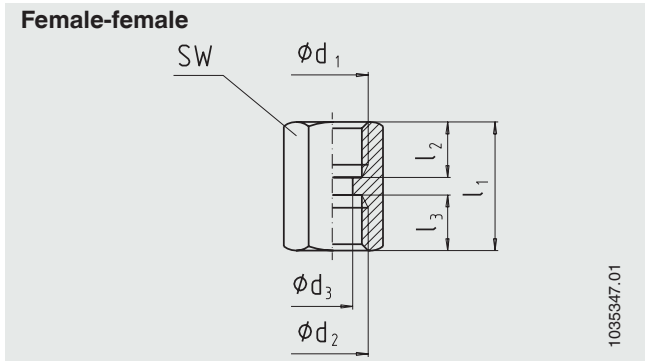
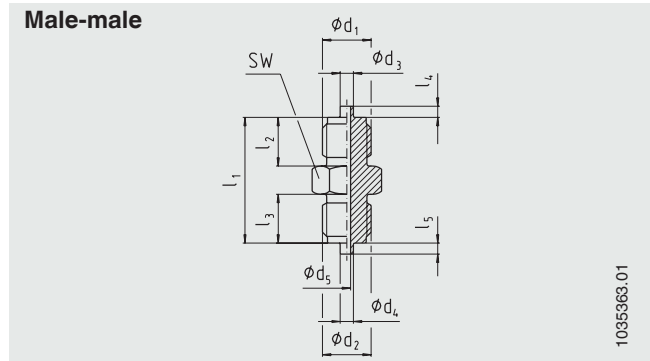
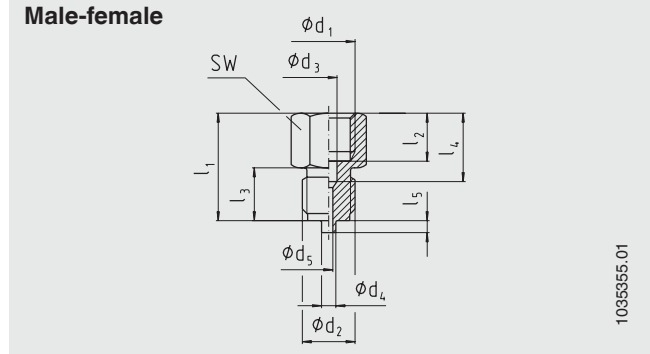

Design	Connection <sup>1)</sup>		Dimensions in mm								flats	Material	Order no.
	d <sub>1</sub>	d <sub>2</sub>	d <sub>3</sub>	d <sub>4</sub>	d <sub>5</sub>	l <sub>1</sub>	l <sub>2</sub>	l <sub>3</sub>	l <sub>4</sub>	l <sub>5</sub>			
						approx.	approx.	approx.	approx.	approx.			
Male-female	G 1/8	G 1/4 B	4.5	5	3	28	10	13	13	2	14	Ms	9090924
	G 1/8	G 1/2 B	4.5	6	3	35	10	20	13	3	22	Ms	9090207
	G 1/4	G 1/8 B	5.5	-	3	29	13	10	16.5	-	17	Ms	9090215
	G 1/4	G 3/8 B	5.5	5.5	3	33	13	16	16.5	3	19	Ms	9090223
	G 1/4	G 1/2 B	5.5	6	3	38	13	20	16.5	3	22	Ms	9090231
	G 1/4	G 1/2 B	5.5	6	3.5	38	13	20	16.5	3	22	1.4571	9084924
	G 1/4	1/4 NPT	5.5	-	3	30	13	13	16.5	-	17	Ms	9054936
	G 1/4	M10 x 1	5.5	-	3	29	13	10	16.5	-	17	Ms	9064931
	G 1/4	M12 x 1.5	5.5	5	3	32	13	13	16.5	2	17	Ms	9090240
	G 3/8	G 1/4 B	7	5	3	36	16	13	19.5	2	22	Ms	9090258
	G 3/8	G 1/2 B	7	6	3	43	16	20	19.5	3	22	Ms	9090266
	G 1/2	G 1/4 B	7	5	3	41	19	13	24.5	2	27	Ms	9090274
	G 1/2	G 1/4 B	7	5	3.5	41	19	13	24.5	2	27	St	9074937
	G 1/2	1/4 NPT	7	-	3	43	19	13	24.5	-	27	Ms	9044930
	G 1/2	1/4 NPT	7	-	3.5	43	19	13	24.5	-	27	1.4571	9074929
	G 1/2	G 3/8 B	7	5.5	3	45	19	16	24.5	3	27	Ms	9090282
	G 1/2	G 3/8 B	7	5.5	3.5	45	19	16	24.5	3	27	1.4571	9024930
	G 1/2	G 1/2 B	7	6	3.5	46	19	20	24.5	3	27	1.4571	9094920
	G 1/2	1/2 NPT	7	-	3.5	44	19	19	24.5	-	27	1.4571	9064923
	G 1/2	1/2 NPT	7	-	3	44	19	19	24.5	-	27	Ms	9034935
	G 1/2	G 3/4 B	7	6	3	45	19	20	24.5	5	27	Ms	9090290
	G 1/2	M12 x 1.5	7	5	3	41	19	13	24.5	2	27	Ms	9090304
	G 1/2	M20 x 1.5	7	6	3.5	46	19	20	24.5	3	27	1.4571	9014934
G 1/2	M20 x 1.5	7	6	3	46	19	20	24.5	3	27	Ms	9090312	
M12 x 1.5	G 1/8 B	5.5	-	3	29	13	10	16.5	-	17	Ms	9090320	
M12 x 1.5	G 1/4 B	5.5	5	3	32	13	13	16.5	2	17	Ms	9090339	
M12 x 1.5	G 3/8 B	5.5	5.5	3	33	13	16	16.5	3	19	Ms	9090347	
M20 x 1.5	G 1/2 B	7	6	3	46	19	20	24.5	3	27	Ms	9090355	
Female-female	G 1/8	G 1/8	4.5	-	-	22	10	10	-	-	14	Ms	9084932
	G 1/4	G 1/8	5.5	-	-	26	13	10	-	-	17	Ms	9094938
	G 1/4	G 1/4	5.5	-	-	30	13	13	-	-	17	Ms	9090363
	G 1/2	G 1/4	7	-	-	36	19	13	-	-	27	1.4571	9014942
	G 1/2	G 1/2	7	-	-	43	19	19	-	-	27	1.4571	9024948
	G 1/2	G 1/2	7	-	-	43	19	19	-	-	27	Ms	9090371
	G 1/2	M20 x 1.5	7	-	-	43	19	19	-	-	27	Ms	9091700
	G 1/2	M20 x 1.5	7	-	-	43	19	19	-	-	27	St	9091718
G 1/2	M20 x 1.5	7	-	-	43	19	19	-	-	27	1.4571	9091726	
Male-male	G 1/4 B	G 1/4 B	5	5	3	34	13	13	2	2	14	Ms	9090380
	G 1/2 B	G 1/2 B	6	6	3	50	20	20	3	3	22	Ms	9090398
	G 1/2 B	G 1/2 B	6	6	3.5	50	20	20	3	3	22	1.4571	9034943
	G 1/2 B	1/2 NPT	6	-	3.5	49	20	-	3	-	22	1.4571	9044949
SS nipple	G 1/8	G 1/4 B	-	5	-	14.5	11	-	-	2	-	Ms	9091076
	G 1/8	1/4 NPT	-	-	-	13.5	11	-	-	-	-	Ms	9014950
	G 1/4	3/8 NPT	-	-	-	19	15.5	-	-	-	-	Ms	9024956
	G 1/4	3/8 NPT	-	-	-	19	15.5	-	-	-	-	1.4571	9074945
	G 1/4	G 3/8 B	-	5.5	-	19	15.5	-	-	3	--	1.4571	9064940
	G 1/4	G 3/8 B	-	5.5	-	19	15.5	-	-	3	-	Ms	9091084
	G 1/4	G 1/2 B	-	6	-	19	15.5	-	-	3	-	Ms	9091092
	G 1/4	G 1/2 B	-	6	-	19	15.5	-	-	3	-	1.4571	9054944
	G 1/4	1/2 NPT	-	-	-	19	15.5	-	-	-	-	Ms	9034951
	G 1/4	1/2 NPT	-	-	-	19	15.5	-	-	-	-	1.4571	9084940
G 1/4	M20 x 1.5	-	6	-	19	15.5	-	-	3	-	Ms	9094946	
LH-RH union DIN 16283	G 1/2-RH	G 1/2-LH	21.5	-	-	36	15.5	15.5	-	-	27	Ms	9090401
	G 1/2-RH	G 1/2-LH	21.5	-	-	36	15.5	15.5	-	-	27	St	9090410
	G 1/2-RH	G 1/2-LH	21.5	-	-	36	15.5	15.5	-	-	27	1.4571	9092412
	G 1/2-RH	M20 x 1.5-LH	21.5	-	-	36	15.5	15.5	-	-	27	Ms	9090428
	G 1/2-RH	M20 x 1.5-LH	21.5	-	-	36	15.5	15.5	-	-	27	St	9090436
M20 x 1.5-RH	M20 x 1.5-LH	20.5	-	-	36	15.5	15.5	-	-	27	Ms	9090444	

Adapters with different thread combinations are possible (minimum purchase quantity 500 pieces), not available ex-stock.

1) Connections per EN 837-1 (exception: G 3/4 B)

Design	Connection <sup>1)</sup>		Dimensions in mm								flats	Mate- rial	Order no.	
	d <sub>1</sub>	d <sub>2</sub>	d <sub>3</sub>	d <sub>4</sub>	d <sub>5</sub>	l <sub>1</sub>	l <sub>2</sub>	l <sub>3</sub>	l <sub>4</sub>	l <sub>5</sub>				
								approx.	approx.	approx.	approx.			
<b>Union nut DIN 16284</b>	G ¼	PN 250	6.5	-	-	22	17	-	-	-	17	Ms	9090479	
	G ¼	PN 400	6.5	-	-	22	17	-	-	-	17	St	9090487	
	G ½	PN 250	12.5	-	-	30	24	-	-	-	27	Ms	9090495	
	G ½	PN 400	12.5	-	-	30	24	-	-	-	27	St	9090509	
	G ½	PN 400	12.5	-	-	30	24	-	-	-	27	1.4571	9092382	
	M12 x 1.5	PN 250	6.5	-	-	22	17	-	-	-	17	Ms	9090517	
	M20 x 1.5	PN 250	12.5	-	-	30	24	-	-	-	27	Ms	9090525	
<b>Nipple DIN 16284</b>	for G ¼ / M12 x 1.5	9.5	5.5	6	2.5	30	-	6	4	-	-	Ms <sup>3)</sup>	9090533	
	for G ¼ / M12 x 1.5	9.5	5.5	6	2.5	30	-	6	4	-	-	St <sup>3)</sup>	9090541	
	for G ½ / M20 x 1.5	17.5	7	12	3.5	30	-	6	6	-	-	Ms <sup>3)</sup>	9090550	
	for G ½ / M20 x 1.5	17.5	7	12	3.5	30	-	6	6	-	-	St <sup>3)</sup>	9090568	
	for G ½ / M20 x 1.5	17.5	7	12	3.5	30	-	6	6	-	-	1.4571	9092390	
<b>Solderless compression fitting with ferrule <sup>2)</sup></b>	G ¼	PN 100	4	-	-	33	14.5	-	-	-	19/10	St	9090932	
	G ¼	PN 250	6	-	-	37	14.5	-	-	-	19/14	St	9090452	
	G ½	PN 600	6	-	-	46	20	-	-	-	27/17	St	9090460	
	G ½	PN 600	6	-	-	46	20	-	-	-	27/17	1.4571	9091734	
	G ½	PN 600	8	-	-	46	20	-	-	-	27/19	St	9090940	
	G ½	PN 600	8	-	-	46	20	-	-	-	27/19	1.4571	9091742	
	G ½	PN 600	10	-	-	47	20	-	-	-	27/22	St	9091246	
	G ½	PN 600	10	-	-	47	20	-	-	-	27/22	1.4571	9091750	
	G ½	PN 600	12	-	-	47	20	-	-	-	27/24	St	9091254	
	G ½	PN 600	12	-	-	47	20	-	-	-	27/24	1.4571	9091769	
<b>Flange set</b>														
	G ¾	≤ 4,000 bar	Dimensions, see drawing									St	9091165	

Adapters with different thread combinations are possible (minimum purchase quantity 500 pieces), not available ex-stock.

1) Connections per EN 837-1 (exception: G ¾ B)

2) Supplied with ferrule. From PN 250 upwards, the following pressure reductions on the appropriate pressure levels are required for higher temperatures:  
 at 100 °C = 11 %      at 200 °C = 20 %      at 300 °C = 29 %      at 400 °C = 33 %

3) Ms = Cu Zn 39 Pb 3 (2.0401)  
 St = 9 S Mn Pb 28 (1.0718)

## Weld-on adapters

With parallel pipe thread per EN 837-1 <sup>1)</sup>

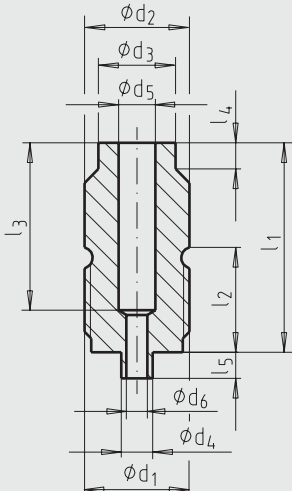

1273515.01

Per DIN 16282, Form 6 with left-hand thread LH  
 for LH/RH union

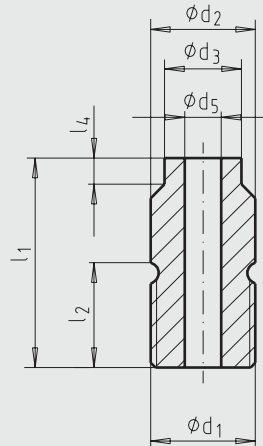

1273515.01

Standard	d <sub>1</sub>	d <sub>2</sub> SW	d <sub>3</sub>	d <sub>4</sub>	d <sub>5</sub>	d <sub>6</sub> max.	l <sub>1</sub>	l <sub>2</sub>	l <sub>3</sub>	l <sub>4</sub>	l <sub>5</sub>	Order no.	
												Material 1.4571	St
EN 837-1	G ½ B	20	14.7	6	7	4	40	20	32	5	5	9094962	9095020
	M20 x 1.5 <sup>2)</sup>	20	14.7	6	7	4	40	20	32	5	5	9094970	-
	½ NPT	20	14.7	6	7	4	40	20	32	5	5	9094989	9095047
DIN 16282	G ½ B - LH	20	14.7	-	7	-	40	20	-	5	5	9094997	9095055
	M20 x 1.5 - LH <sup>2)</sup>	20	14.7	-	7	-	40	20	-	5	5	9095004	-

1) Like the previous Form 4 per DIN 16282

2) For metric ISO - threads based upon the withdrawn DIN 16288 : 1987.  
These threads are no longer standardised in EN 837 and DIN 16282

## Rotatable gauge adapters (swivel adapters)

This 360° swivel connection (swivel adapter) enables the simple orientation of pressure measuring instruments. The measuring instrument can be turned through a 360° range. Also when using an NPT thread, the pressure measuring instrument can be rotated to the position in which the pressure can be read optimally on the dial.

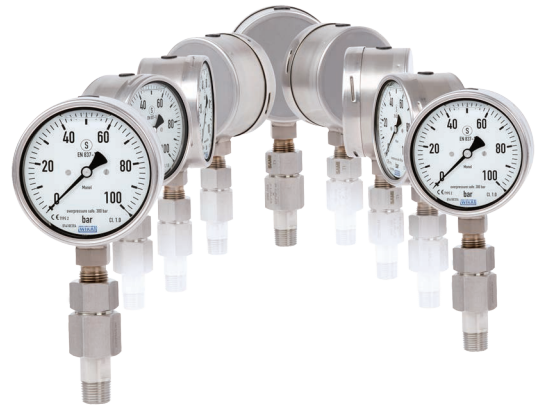

### Installation instructions

- First, mount the gauge adapter with the process connection end ② to the piping (take care it is sealed).
- Then fasten the pressure measuring instrument to the measuring instrument end ①.
- Turn the pressure gauge so the window is in the desired position, such that the pressure can be read optimally from the dial.
- Finally, tighten the entire system with the swivel nut ③. Fix the pressure measuring instrument in the desired display direction.

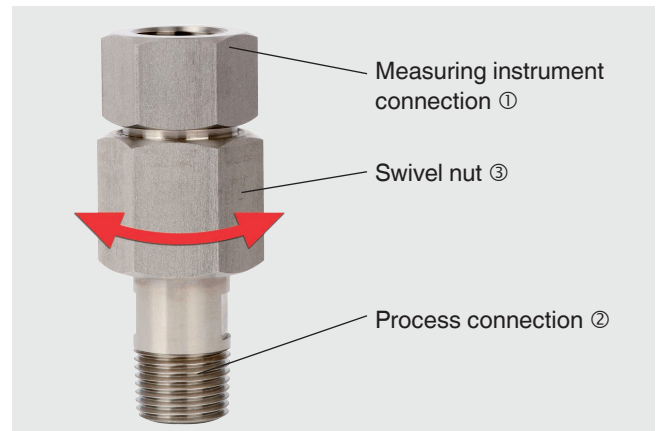

### Pressure-temperature-diagram

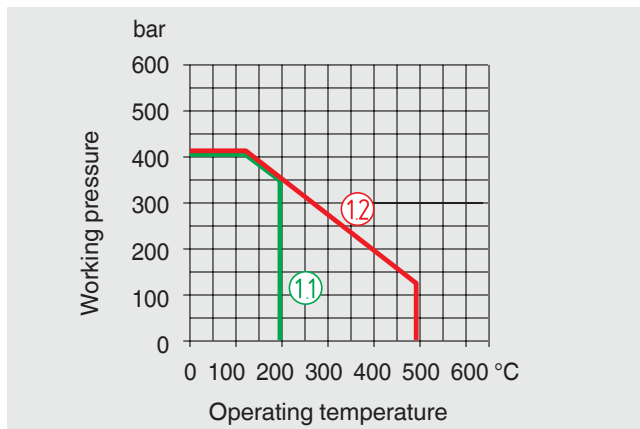

All swivel connectors with PTFE seal:  
See pressure-temperature curve 1.1  
All other swivel connectors:  
See pressure-temperature curve 1.2

Measuring instrument connection ①	Process connection ②	Material	Sealing	Working pressure	Certificate 3.1 Mat. 1)	NACE certificate 2)	Design	Order no.
¼ NPT female	¼ NPT male	1.4571	PTFE	PN 420	yes	-	1	14037344
½ NPT female	¼ NPT male	1.4571	PTFE	PN 420	yes	-	1	14037347
¼ NPT female	½ NPT male	1.4571	PTFE	PN 420	yes	yes	1	14037350
½ NPT female	½ NPT male	2.4819	PTFE	PN 420	yes	yes	1	11390388
½ NPT female	½ NPT male	Inconel 625, 1.4571	PTFE	PN 420	yes	yes	1	11390396
½ NPT female	½ NPT male	Monel 400, 1.4571	PTFE	PN 420	yes	yes	1	14014609
½ NPT female	½ NPT male	1.4571	PTFE	PN 420	-	-	1	2132851
½ NPT female	½ NPT male	1.4571	PTFE	PN 420	yes	-	1	2481001
½ NPT female	½ NPT male	1.4571	PTFE	PN 420	yes	yes	1	11144165
½ NPT female	½ NPT male	Monel 400, 1.4571	PTFE	PN 420	yes	-	1	2477161
½ NPT female	¾ NPT male	316L (1.4404)	PTFE	PN 420	yes	-	1	11051418
G ½ female	G ½ B male	1.4571	-	PN 420	yes	-	4	11036672
G ½ female	½ NPT male	1.4571	-	PN 420	yes	-	2	11148144
G ½ female	½ NPT male	316L (1.4404)	-	PN 420	yes	yes	2	11570670
G ½ female	½ NPT male	Monel 400	-	PN 420	yes	yes	2	11570688

1) 3.1 material test certificate per EN 10204  
2) NACE design per ISO 15156-2

Design 1

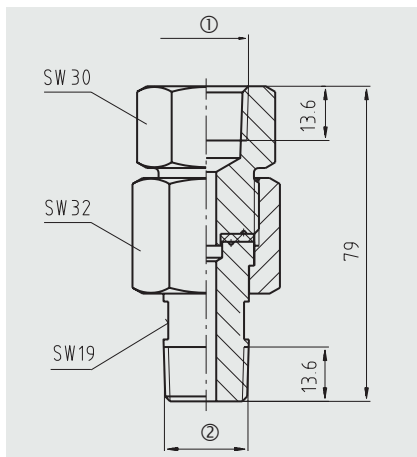

Design 2

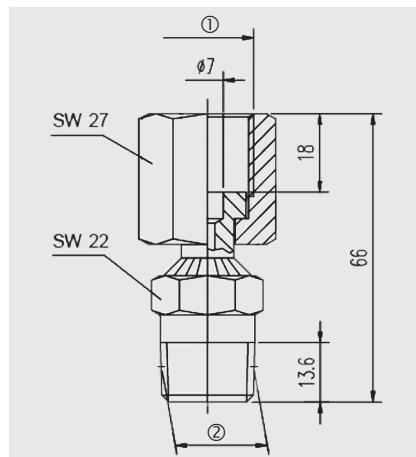

Design 4

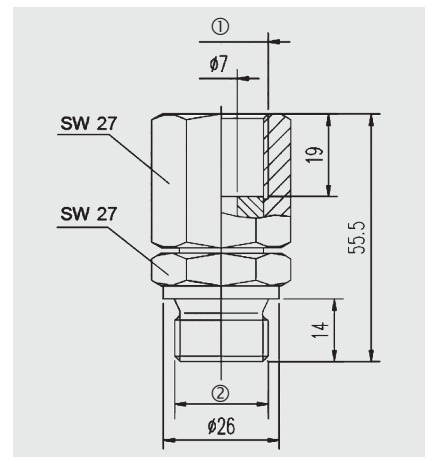

### Ordering information

To order, the 7-digit number is sufficient. Other options require additional specification.

© 2008 WIKA Alexander Wiegand SE & Co. KG, all rights reserved.  
The specifications given in this document represent the state of engineering at the time of publishing.  
We reserve the right to make modifications to the specifications and materials.



**WIKAL Alexander Wiegand SE & Co. KG**  
Alexander-Wiegand-Straße 30  
63911 Klingenberg/Germany  
Tel. +49 9372 132-0  
Fax +49 9372 132-406  
info@wika.de  
www.wika.de