

Hand & mechanical directional valves

ISO 4401 sizes 06, 10, 16 and 25

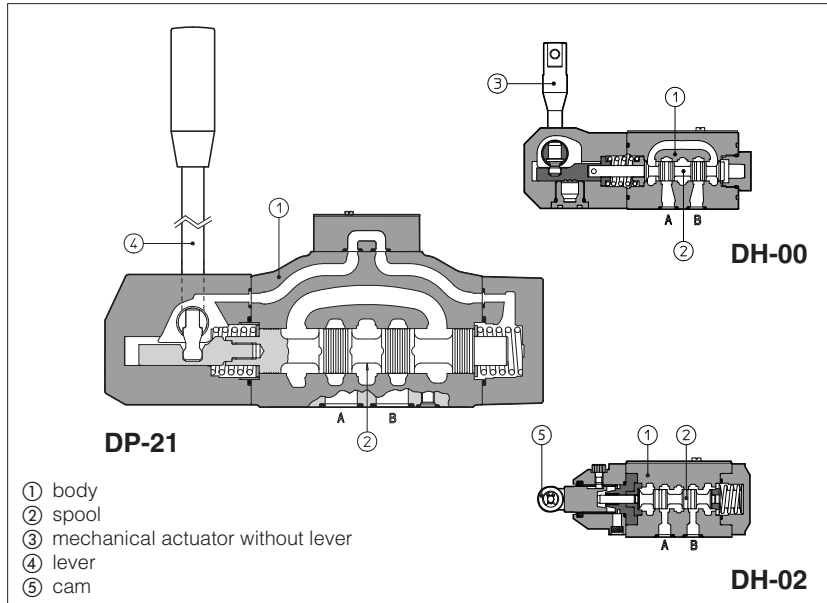

Hand & mechanical operated directional valves are spool type, three or four way, two or three position valves, available with following actuator types:

- mechanical actuator: general purpose execution for connection to customer device for the valve's remote operation
- hand-lever
- cam (only for DH and DK).

Valve sizes and max flow:

- DH-00, 01** = size 06, flow up to 80 l/min
- DH-02** = size 06, flow up to 50 l/min
- DK-10 (11)** = size 10, flow up to 150 l/min
- DK-12** = size 10, flow up to 140 l/min
- DP-2** = size 16, flow up to 300 l/min
- DP-4** = size 25, flow up to 700 l/min

Max pressure:

- 350 bar** for DH-0*, DP-2, DP-4
- 315 bar** for DK-1*

1 MODEL CODE

DH-0	1	1	3	/	C	/	A	**	/	*
Directional control valve, size: DH-0 = 06 DK-1 = 10 DP-2 = 16 DP-4 = 25										Seals material: - = NBR PE = FKM BT = HNBR (1)
Type of actuator: 0 = mechanical, without lever 1 = hand-lever 2 = cam (only for DH-0 and DK-1)										Series number
Valve configuration, see sections 2 and 3 0 = 3 positions, without springs 1 = 3 positions, spring centered 2 = 2 positions, spring return 3 = 2 positions, spring return 4 = 3 positions, with detent 5 = 2 positions, with detent 6 = 2 positions, with detent 7 = 2 positions, spring return 8 = 2 positions, spring return										Options: A = actuator device mounted on side of port B I or E to be specified for DH-00, DH-01 and DK-00, DK-01 with configuration 6, 7, 8, see section 3 for hydraulic connections Only for DK-1: Y = external drain
										Only for DH-01 hand-lever valves: C = short hand - lever
										Spool type, see section 3

(1) BT option available only for DH-00, DH-01, DK-10 and DK-11

2 RANGE OF VALVE'S MODELS

VALVE TYPE	SIZE	VALVE CONFIGURATION									
		0	1	2	3	4	5	6	7	8	
DH-00	06	•	•	•	•	•	•	•	•	•	
DH-01		•	•	•	•	•	•	•	•	•	
DH-02					•				•	•	
DK-10	10	•	•	•	•	•	•	•	•	•	
DK-11		•	•	•	•	•	•	•	•	•	
DK-12					•				•	•	
DP-20	16		•		•	•	•				
DP-21			•		•	•	•				
DP-40			•		•	•	•				
DP-41	25		•		•	•	•				

3 CONFIGURATIONS and SPOOLS - for intermediate passages, see tab. E001

DH-00*, DH-01* and DK-10*, DK-11* - mechanical and hand lever actuator

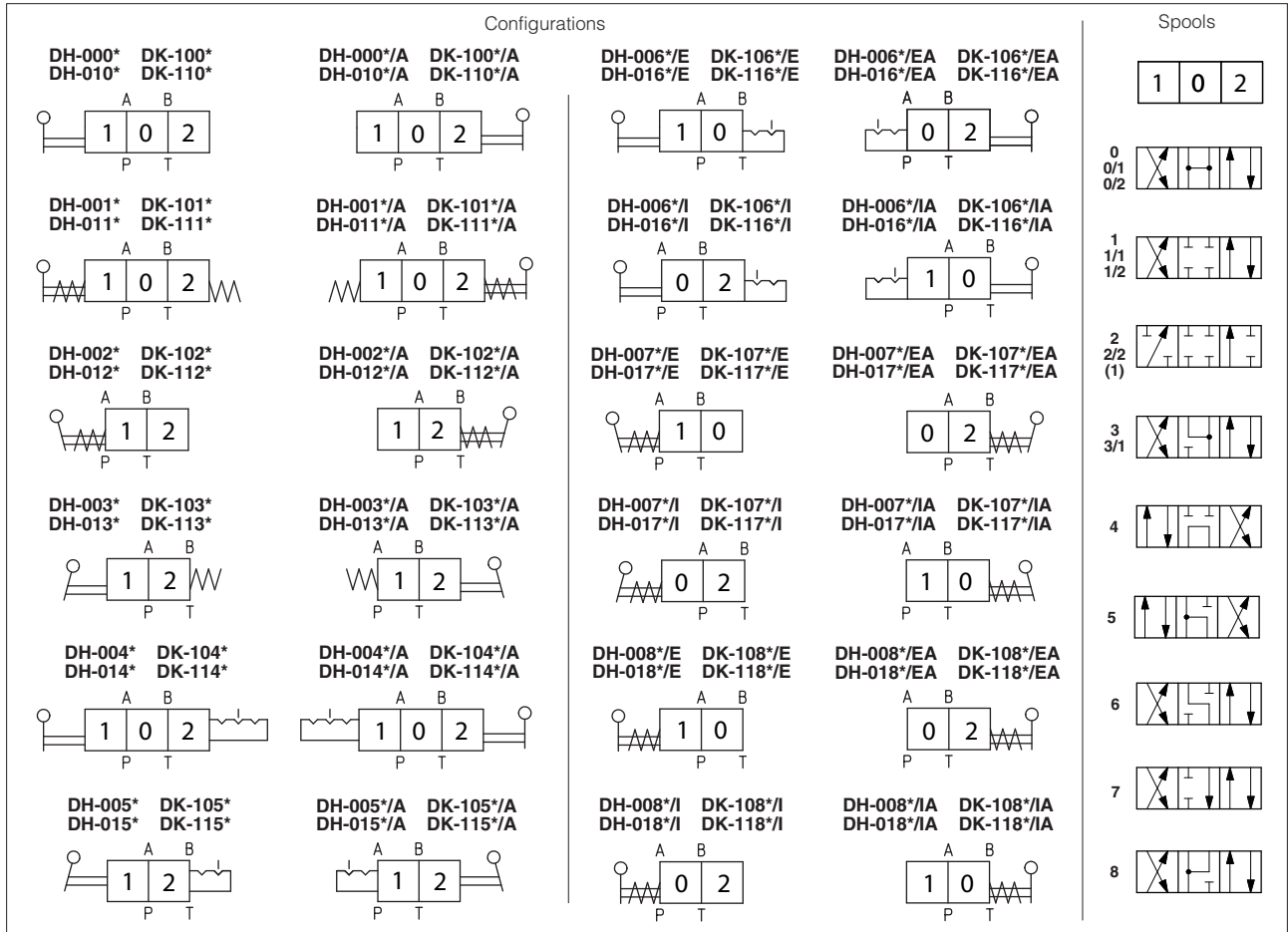

NOTE: configurations 2 and 3 are available only with spools type 0/2, 1/2, 2/2
(1) spools type 2 and 2/2 available only for DH

DP-20*, DP-21*, DP-40*, DP-41* - hand lever actuator

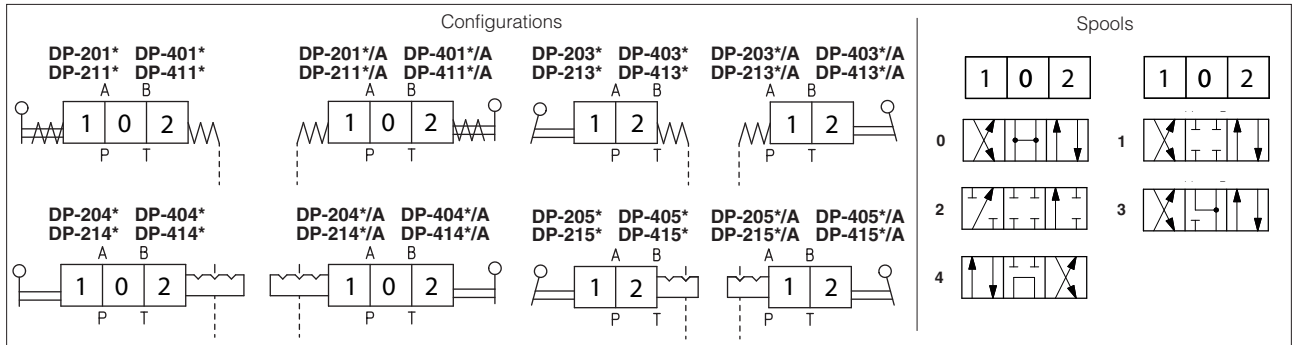

DH-02*, DK-12* - cam actuator

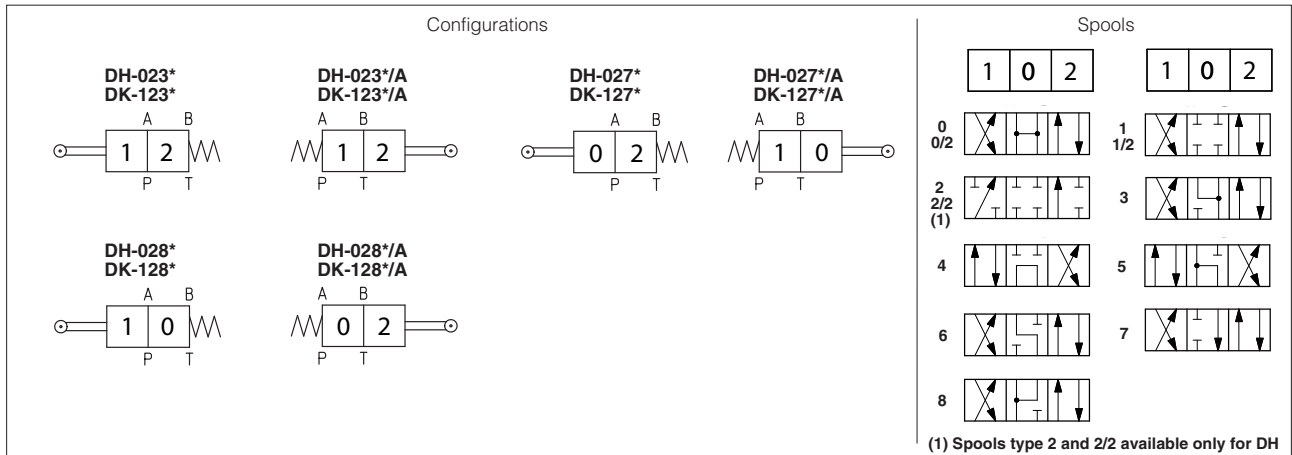

(1) Spools type 2 and 2/2 available only for DH

NOTE: spools type 0/2, 1/2, 2/2 are only used for valves type DH-023*/2 and DK 123*/2;

4 GENERAL CHARACTERISTICS

Assembly position	Any position except for configuration 0 (without spring) that must be installed with horizontal axis		
Subplate surface finishing to ISO 4401	Acceptable roughness index, Ra ≤0,8 recommended Ra 0,4 - flatness ratio 0,01/100		
MTTFd valves according to EN ISO 13849	150 years, see technical table P007		
Ambient temperature range	Standard = -30°C ÷ +70°C /PE option = -20°C ÷ +70°C /BT option = -40°C ÷ +70°C		
Storage temperature range	Standard = -30°C ÷ +80°C /PE option = -20°C ÷ +80°C /BT option = -40°C ÷ +80°C		
Flow direction	As shown in the symbols of tables 3		
Surface protection	Zinc coating with black passivation		
Corrosion resistance	Salt spray test (EN ISO 9227) > 200h		
Compliance	RoHS Directive 2011/65/EU as last update by 2015/863/EU REACH Regulation (EC) n°1907/2006		
Operating pressure	DH	P, A, B = 350 bar T = 250 bar (160 bar for DH-02)	
	DK	P, A, B = 315 bar T = 250 bar	
	DP	P, A, B, X = 350 bar T = 250 bar for external drain (standard); Ports Y = 0 bar	
Maximum flow	DH-00, DH-01 DH-02	80 l/min 50 l/min	
	DK-10, DK-11 DK-12	150 l/min 140 l/min	
	DP-2 DP-4	300 l/min 700 l/min	
Activation force without pressure on port T (nominal values ± 10%)	DH	DH-00* : 70 N; DH-004* : 40 N; DH-01* : 36 N; DH-014* : 21 N; DH-01*/C : 43 N; DH-014*/C : 25 N; DH-02* : 81 N;	
	DK	DK-10* : 86 N; DK-104 : 41 N; DK-11* : 44 N; DK-114* : 21 N; DK-12* : 120 N	
	DP	DP-201* : 168 N; DP-203* : 73 N; DP-211* : 38 N; DP-213* : 16 N; DP-401* : 365 N; DP-403* : 132 N; DP-411* : 76 N; DP-413* : 28 N;	

5 SEALS AND HYDRAULIC FLUIDS - For other fluids not included in above table, consult our technical office

Seals, recommended fluid temperature	NBR seals = (standard) -30°C ÷ +80°C, with HFC hydraulic fluids = -20°C ÷ +50°C FKM seals = (/PE option) -20°C ÷ +80°C		
Recommended viscosity	15 ÷ 100 mm ² /s - max allowed range 2,8 ÷ 500 mm ² /s		
Max fluid contamination level	ISO4406 class 20/18/15 NAS1638 class 9, see also filter section at www.atos.com or KTF catalog		
Hydraulic fluid	Suitable seals type	Classification	Ref. Standard
Mineral oils	NBR, FKM	HL, HLP, HLPD, HVLP, HVLPD	DIN 51524
Flame resistant without water	FKM	HFDU, HFDR	ISO 12922
Flame resistant with water	NBR	HFC	

6 Q/ΔP DIAGRAMS based on mineral oil ISO VG 46 at 50°C

DH-02

Flow direction \ Spool type	P→A	P→B	A→T	B→T	P→T
0, 0/2	C	C	C	C	
1, 1/2	A	A	A	A	
2, 2/2, 3	A	A	C	C	
4, 5	D	D	D	D	A
6, 7	A	A	C	A	
8	C	C	B	B	

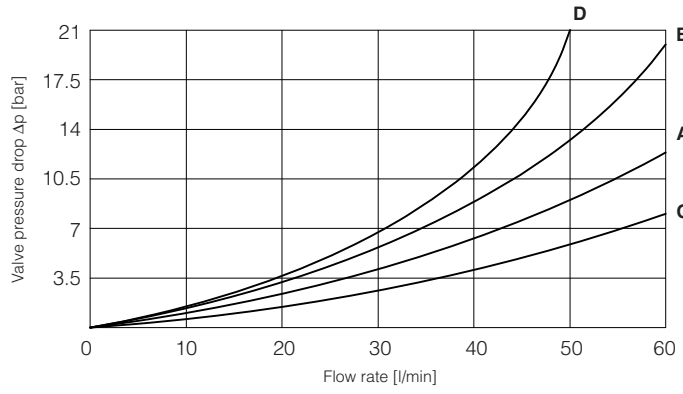

DH-00, DH-01

Flow direction \ Spool type	P→A	P→B	A→T	B→T	P→T
0, 0/1	A	A	B	B	C
1, 1/1	B	B	C	C	
3, 3/1	C	C	B	B	
4, 5	E	E	F	F	D
1/2, 0/2, 6, 7	C	C	D	D	
8	A	A	D	D	
2	D	D			
2/2	E	E			

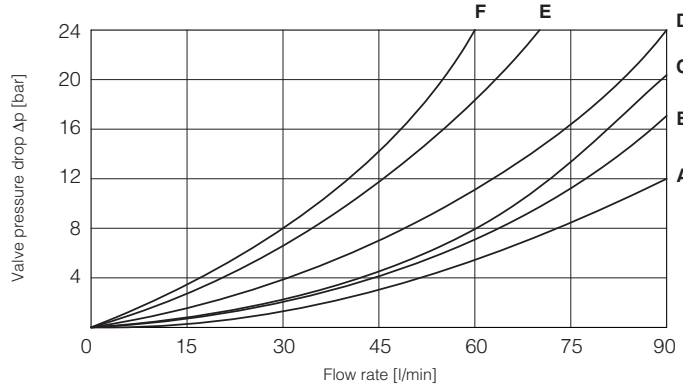

DK-*

Flow direction \ Spool type	P→A	P→B	A→T	B→T	P→T
0, 0/1, 0/2	A	A	B	B	
1, 1/1, 6, 8	A	A	D	C	
3, 3/1, 7	A	A	C	D	
4	B	B	B	B	E
5	A	B	C	C	F
1/2	B	C	C	B	

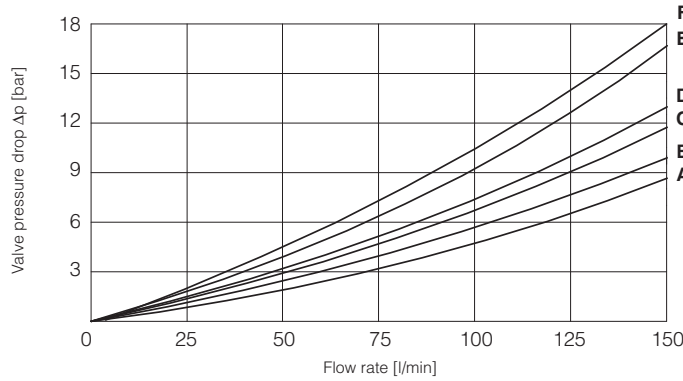

DP-2*

Flow direction \ Spool type	P→A	P→B	A→T	B→T	P→T
1, 3	A	A	B	C	
0	A	A	C	D	B
2	A	A			
4	B	B	F	G	E

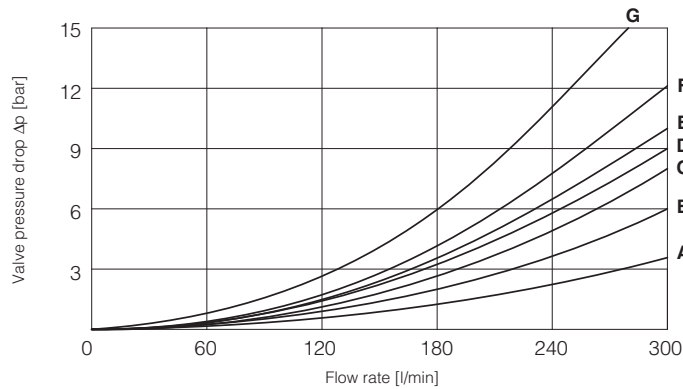

DP-4*

Flow direction \ Spool type	P→A	P→B	A→T	B→T	P→T
1	A	A	A	C	
0	C	B	C	D	E
2	A	A			
3	A	A	C	E	
4	B	B	F	G	G

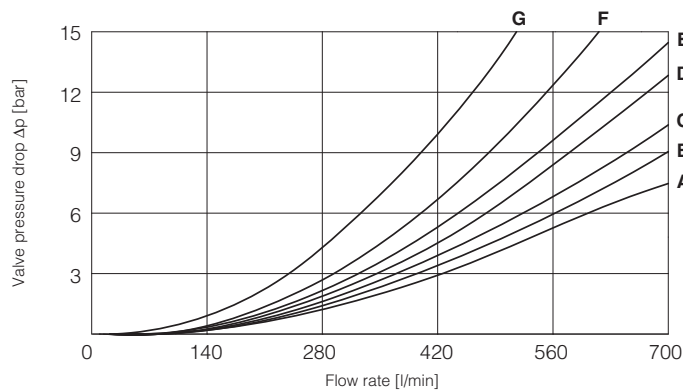

7 DIMENSIONS OF HAND & MECHANICAL OPERATED VALVES ISO 4401 SIZE 06 [mm]

DH-00**

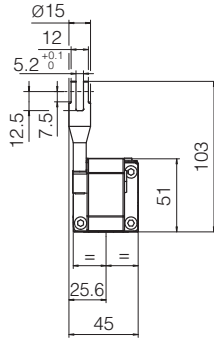
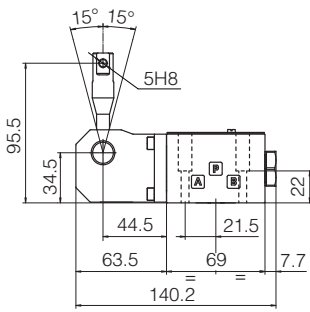

Mass: 1,2 Kg

DH-01**

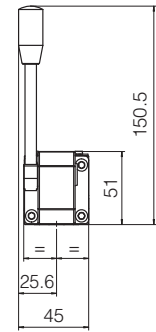
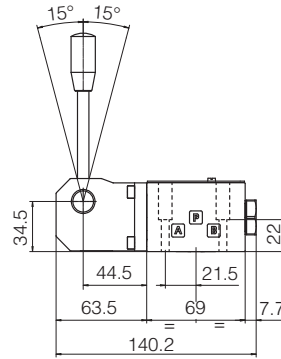

Mass: 1,6 Kg

DH-01/C**

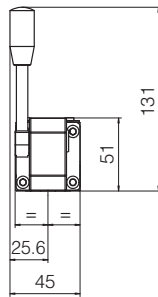
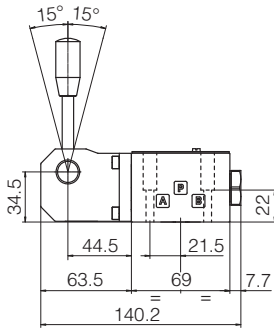

DH-02**

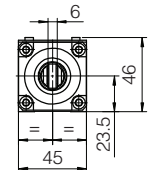
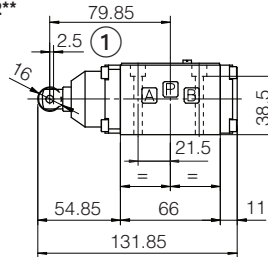

Mass: 1,2 Kg

① Working stroke: 2,5 mm; extra-stroke: 0,5 mm max.

ISO 4401: 2005

Mounting surface: 4401-03-02-0-05 (see table P005)

Fastening bolts:

DH-02**: 4 socket head screws M5x50 class 12.9

Other version 4 socket head screws M5x30 class 12.9

Tightening torque = 8 Nm

Diameter of ports A, B, P, T: Ø = 7,5 mm (max)

Seals: 4 OR 108

8 DIMENSIONS OF HAND & MECHANICAL OPERATED VALVES ISO 4401 SIZE 10 [mm]

DK-10**

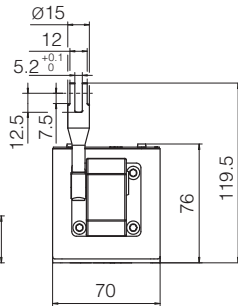
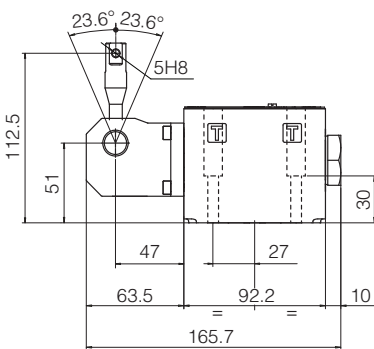

Mass: 2,5 Kg

DK-11**

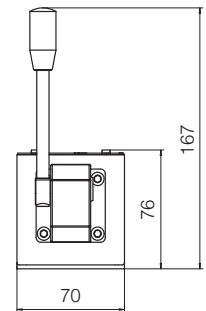
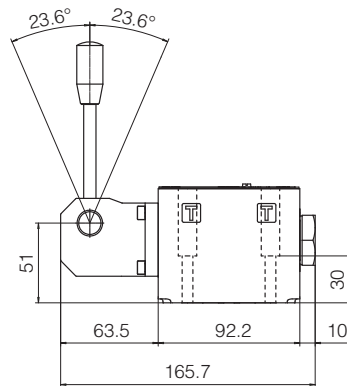

Mass: 2,8 Kg

DK-12**

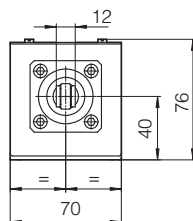
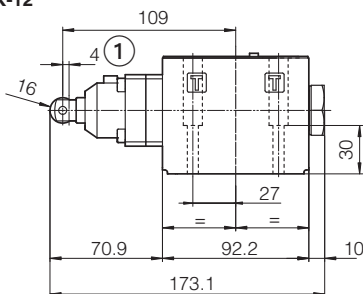

Mass: 2,5 Kg

ISO 4401: 2005

Mounting surface: 4401-05-05-0-05 (see table P005)

(Without X port, Y port optional)

Fastening bolts: 4 socket head screws M6x40 class 12.9

Tightening torque = 15 Nm

Diameter of ports A, B, P, T: Ø = 11,2 mm (max)

Seals: 5 OR 2050

① Working stroke: 4 mm; extra-stroke: 0,5 mm max.

9 DIMENSIONS OF HAND & MECHANICAL OPERATED VALVES ISO 4401 SIZE 16 [mm]

DP-21

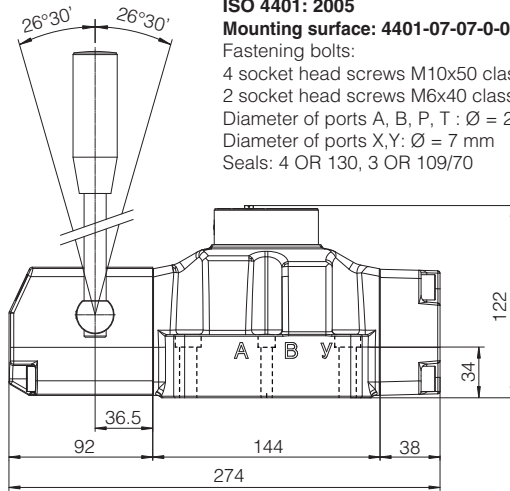

ISO 4401: 2005

Mounting surface: 4401-07-07-0-05 (see table P005)

Fastening bolts:

4 socket head screws M10x50 class 12.9, Tightening torque = 70 Nm

2 socket head screws M6x40 class 12.9, Tightening torque = 15 Nm

Diameter of ports A, B, P, T : $\varnothing = 20$ mm

Diameter of ports X,Y: $\varnothing = 7$ mm

Seals: 4 OR 130, 3 OR 109/70

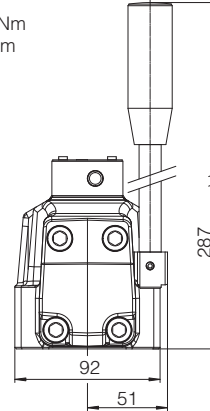

Mass: 10 Kg

DP-20

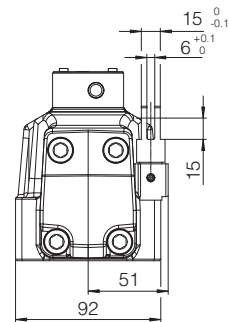
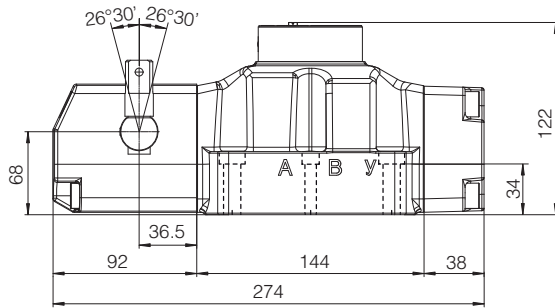

Mass: 9,7 Kg

10 DIMENSIONS OF HAND & MECHANICAL OPERATED VALVES ISO 4401 SIZE 25 [mm]

DP-41

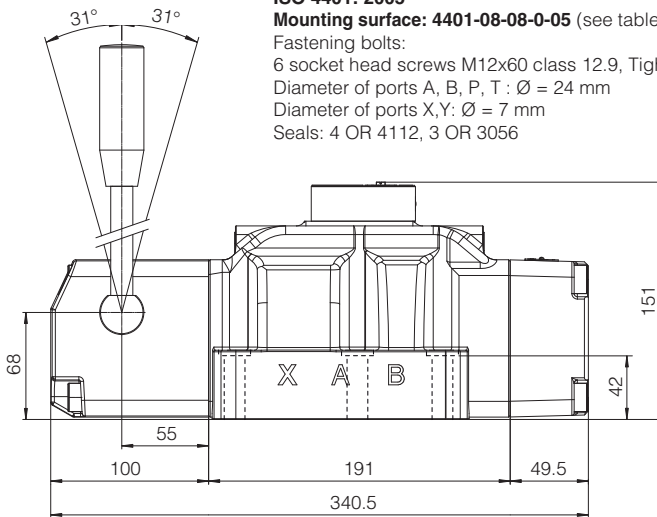

ISO 4401: 2005

Mounting surface: 4401-08-08-0-05 (see table P005)

Fastening bolts:

6 socket head screws M12x60 class 12.9, Tightening torque = 125 Nm

Diameter of ports A, B, P, T : $\varnothing = 24$ mm

Diameter of ports X,Y: $\varnothing = 7$ mm

Seals: 4 OR 4112, 3 OR 3056

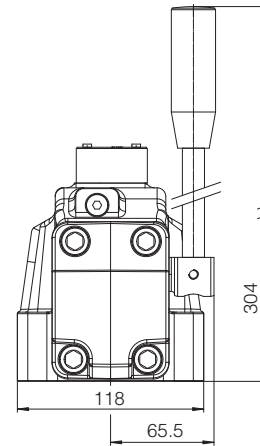

Mass: 15,5 Kg

DP-40

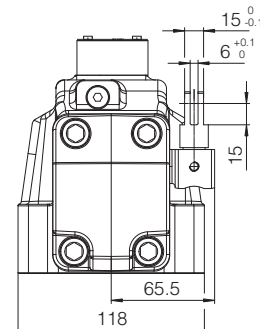
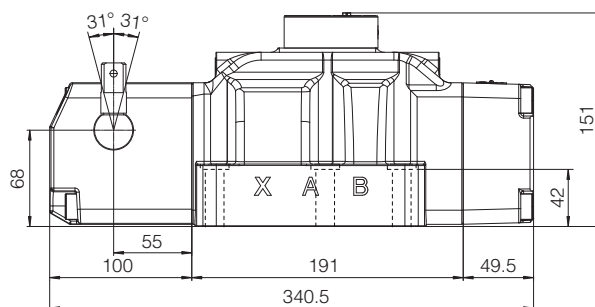

Mass: 15,2 Kg