

2 SERVOCYLINDERS TYPE CKF

2.1 Magnetosonic transducers - basic working principles

The magnetosonic transducer is composed by: a waveguide element ① fixed to the cylinder's body, a permanent magnet ② rigidly connected to the cylinder's rod and an integral electronics signal conditioning ③ located on the rear head.

The position measurement is based upon the magnetostriction phenomenon: the electronics signal conditioning ③ generates a short current pulse that travels through the waveguide ①. When this pulse meets the magnetic field of the permanent magnet ②, a torsional wave is generated and it travels back to the electronics signal conditioning.

The position of the moving magnet is thus accurately determined by measuring the elapsed time between the application of the current pulse and the arrival of the torsional wave, thanks to their constant ultrasonic speed. Sensor electronics signal conditioning transforms this measurement into the analogic output feedback signal.

The contactless construction of the position transducer ensures a long working life and allows its use even in hard environmental conditions (shocks, vibrations etc.) or high working frequencies.

The transducer can be replaced without disassembling the cylinder, providing a great advantage of easy and quick maintenance.

Magnetosonic transducers, particularly simple and cost-effective, makes the CKF servocylinders commonly used as alternatives to external absolute encoders or to potentiometric transducers.

2.2 Output signal

The transducer integral electronics is available with the following configurations:

Analog

A = 4-20 mA
V = 0-10 V

Digital SSI

Q = Binary 24 bit
R = Binary 25 bit
S = Gray 24 bit
U = Gray 25 bit

Example of model code: CKF-63/45*0500-X008 -**A**-B1X1

Digital SSI output is available on request, for other output signals contact our technical office.

2.3 Transducer features

CKF are equipped with "MTS"s magnetosonic transducers, whose main features are shown in the table at side.

2.4 Electronic connections

The 5 or 8 pin male connector M12 is located on the transducer rear head. The straight female cable connector ④ is included in the supply:

CON031 5 pin female connector for analog version
370694 8 pin female connector for digital SSI version

The 90° female connector can be supplied selecting option **M**:

CON041 5 pin 90° female connector for analog version
370699 8 pin 90° female connector for digital SSI version

See the tables at side for electronic connections.

For other connector types or cable outputs, contact our technical office.

2.5 Strokes

From 50 to 2500 mm by increments of 5 mm.

If a not standard stroke is required, contact our technical office.

2.6 Cylinder features

See sections 5, 6 and 7 for sizes, mounting style and dimensions.

See sections from 18 to 26 for materials and options.

2.7 Fluid requirements

CKF servocylinders are suitable for operation with mineral oils with or without additives (**HH, HL, HLP, HLP-D, HM, HV**), fire resistant fluids (**HFA** oil in water emulsion - 90-95% water and 5-10% oil, **HFB** water in oil emulsion - 40% water, **HFC** water glycol - max 45% water) and synthetic fluids (**HFD-U** organic esters, **HFD-R** phosphate esters).

For the proper choice of the sealing system, in relation to the fluid characteristics, see section 25.

Recommended fluid characteristics:

- Viscosity: 15 ÷ 100 mm²/s
- Temperature range: 0 ÷ 70°C
- Fluid contamination class: for normal operation ISO4406 class 18/16/13 NAS1638 class 7. Longer life class 16/14/11 NAS1638 class 5; see also filter section at www.atos.com or KTF catalog.

2.8 Start-up notes

During the start-up it is necessary to bleed off the air from the servocylinder as indicated in section 27.

For other details refer to the start-up instructions included in the supply.

2.9 Warnings

Ensure that the servocylinder and wirings are kept away from strong magnetic field and electrical noise to prevent noises on the feedback signal. Check the electronic connections and switch-off the power supply before connecting or disconnecting the position transducer to avoid electronic damages.

It is recommended to connect the draining port, supplied as standard, to the tank without back pressure, see section 28 for details.

For other types of resolution contact our technical office.

SERVOCYLINDER TYPE CKF

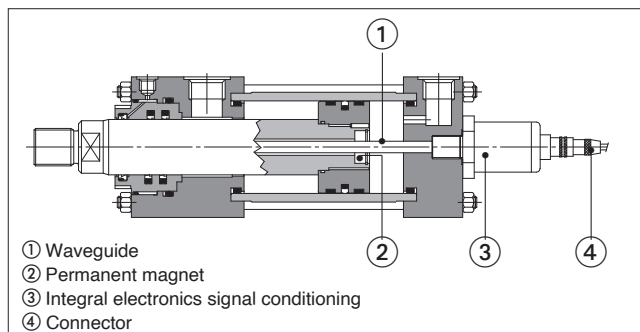

TRANSDUCER FEATURES

	Analog	Digital SSI
Power supply	24 VDC (±15%)	
Outputs signal	0÷10 VDC/ 4÷20 mA	SSI RS 422/485 Standard
Data format (SSI)	NA	Binary / Gray
Data length (SSI)	NA	24 / 25 bit
Resolution	infinite, restricted by the output ripple	50 µm
Linearity	< ± 0,02% F.S (min ± 60 µm)	
Repeatability	< ± 0,005 % F.S. (min ± 20 µm)	
Data speed (only for digital)	70kBd÷1MBd (depending to cables lenght)	
Update frequency	< 3 kHz	1,2÷3,7 kHz (depending to the stroke)
Connection type	5 pin connector M12	8 pin connector M12
Protection degree	IP67 to DIN 40050	
Shock resistance	100g (single shock) / IEC Standard 60068-2-27	
Vibration resistance	15g/10÷2000 Hz / IEC Standard 60068-2-6	
Polarity protection	up to -30 VDC	
Operating temperature	-20 ÷ +75 °C	
Measuring range	50 to 2500 mm (increments of 5 mm)	
Maximum speed	1 m/s	

ELECTRONIC CONNECTIONS - ANALOG

5 PIN female connector (to solder)	PIN	SIGNAL	NOTES
<p>CON031 (Transducer view)</p>	1	V+	Input - power supply 24 VDC (±15%)
	2	OUTPUT	Output - analog signal
	3	V0	Gnd - power supply 0 Vdc
	4	NC	Do not connect
	5	AGND	Gnd - analog signal

ELECTRONIC CONNECTIONS - DIGITAL SSI

8 PIN female connector (to solder)	PIN	SIGNAL	NOTES
<p>370694 (Transducer view)</p>	1	CLOCK +	Output - serial synchronous clock (+)
	2	CLOCK -	Input - serial synchronous clock (-)
	3	DATA +	Output - serial position data (+)
	4	DATA -	Input - serial position data (-)
	5	NC	Do not connect
	6	NC	Do not connect
	7	V+	Input - power supply 24 VDC (±15%)
	8	V0	Gnd - power supply 0 Vdc

3 SERVOCYLINDERS TYPE CKM - PROGRAMMABLES

3.1 Magnetosonic transducers - basic working principles

The magnetosonic transducer is composed by: a waveguide element ① fixed to the cylinder's body, a permanent magnet ② rigidly connected to the cylinder's rod and an integral electronics signal conditioning ③ located on the rear head.

The position measurement is based upon the magnetostriction phenomenon: the electronics signal conditioning ③ generates a short current pulse that travels through the waveguide ①. When this pulse meets the magnetic field of the permanent magnet ②, a torsional wave is generated and it travels back to the electronics signal conditioning.

The position of the moving magnet is thus accurately determined by measuring the elapsed time between the application of the current pulse and the arrival of the torsional wave, thanks to their constant ultrasonic speed. Sensor electronics signal conditioning transforms this measurement into the output feedback signal.

The contactless construction of the position transducer ensures a long working life and allows its use even in hard environmental conditions (shocks, vibrations etc.) or high working frequencies.

The transducer can be replaced without disassembling the cylinder, providing a great advantage of easy and quick maintenance.

Additionally, the only electronics signal conditioning can be easily removed and replaced without removing its case; in this way the cylinder could keep on working avoiding any production-stop time.

CKM servocylinders are characterized by high performances and they are available in several versions.

3.2 Output signal

The transducer integral electronics is available with the following configurations:

Analog

A = 4-20 mA
V = 0-10 V

Digital SSI

Q = Binary 24 bit
R = Binary 25 bit
S = Gray 24 bit
U = Gray 25 bit

Example of model code: CKM-63/45*0500-X008 -AD-B1X1

ETHERNET, I/O LINK and POWERLINK output are available on request, for other output signals contact our technical office.

3.3 Transducer features

CKM are equipped with "MTS"'s magnetosonic transducers, whose main features are shown in the table at side. The integral position transducer is also available with an explosion-proof housing, ATEX certified, for use in explosion-hazardous environments and SIL certified.

Other integral position transducers brands are available on request, contact our technical office.

3.4 Electronic connections

The 6 or 7 pin male connector M16 is located on the transducer rear head. The straight female cable connector ④ is included in the supply:

STCO9131-D06-PG7 6 pin female connector for analog version
STCO9131-D07-PG9 7 pin female connector for digital SSI version

The 90° female connector can be supplied selecting option **M**:

STCO9131-6-PG7 6 pin 90° female connector for analog version
STCO9131-7-PG9 7 pin 90° female connector for digital SSI version

See the tables at side for electronic connections.

For other connector types or cable outputs, contact our technical office.

3.5 Strokes

From 25 to 3000 mm by increments of 5 mm.

If a not standard stroke is required, contact our technical office.

3.6 Cylinder features

See sections ⑤, ⑥ and ⑦ for sizes, mounting style and dimensions.

See sections from ⑧ to ⑫ for materials and options.

3.7 Fluid requirements

For the suitable fluids and the proper choice of the sealing system, in relation to the fluid characteristics, see sections ⑬.

Recommended fluid characteristics:

- Viscosity: 15 ÷ 100 mm²/s

- Temperature range: 0 ÷ 70°C

- Fluid contamination class: for normal operation ISO4406 class 18/16/13 NAS1638 class 7. Longer life class 16/14/11 NAS1638 class 5; see also filter section at www.atos.com or KTF catalog.

3.8 Start-up notes

The output signal of the CKM analog or digital SSI versions is programmable by using proper programming tools to be ordered separately:

253-124 for zero/span setting of analog version

253-135 for complete re-programming of the transducers parameters (resolution, output format, length etc.) of digital SSI version

The sensor electronics case is equipped with two LED that indicate the transducer status, allowing a quick recognition of main possible faults (magnet not detected or out of set-up range).

During the start-up it is necessary to bleed off the air from the servocylinder as indicated in section ⑭.

For other details refer to the start-up instructions included in the supply.

3.9 Warnings

Ensure that the servocylinder and wirings are kept away from strong magnetic field and electrical noise to prevent noises on the feedback signal. Check the electronic connections and switch-off the power supply before connecting or disconnecting the position transducer to avoid electronic damages.

It is recommended to connect the draining port, supplied as standard, to the tank without back pressure, see section ⑮ for details.

SERVOCYLINDER TYPE CKM

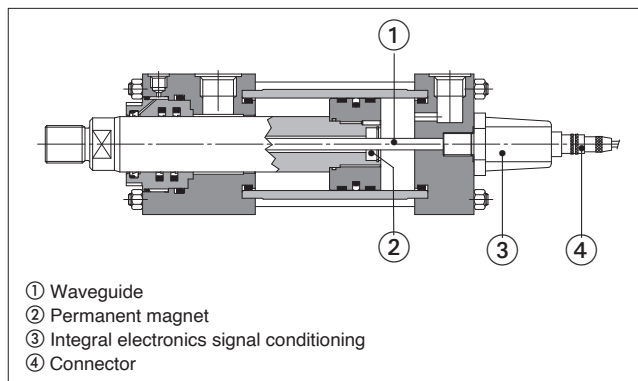

TRANSDUCER FEATURES

	Analog	Digital SSI
Power supply	24 Vdc (±15%)	
Outputs signal	0÷10 Vbc/ 4÷20 mA	SSI RS 422/485 Standard
Data format (SSI)	NA	Binary / Gray
Data length (SSI)	NA	24 / 25 bit
Resolution	16 bit; 0,0015% (min. 1 µm)	5 µm
Linearity	<±0,01% F.S. (min ±50 µm)	<±0,01% F.S. (min ±40 µm)
Repeatability	<±0,001% F.S. (min ±1 µm)	
Hysteresis	< 4 µm	
Data speed (only for digital)	70 kBd÷1MBd (depending to cables lenght)	
Update frequency	0,5÷2kHz (depending to the stroke)	0,5÷3,7kHz (depending to the stroke)
Temperature coefficient	< 30 ppm/°C	< 15 ppm/°C
Connection type	6 pin connector M16 to DIN45322	7 pin connector M16 to DIN45329
Protection degree	IP67 to DIN 40050	
Shock resistance	100g (single hit) / IEC Standard 60068-2-27	
Vibration resistance	15g/10÷2000 Hz / IEC Standard 60068-2-6	
Polarity protection	up to -30 VDC	
Operating temperature	-20 ÷ +75 °C	
Measuring range	25 to 3000 mm (increments of 5 mm)	
Maximum speed	2 m/s	

ELECTRONIC CONNECTIONS - ANALOG

6 PIN female connector (to solder)	PIN	SIGNAL	NOTES
<p>STCO9131-D06-PG7 (Transducer view)</p>	1	OUTPUT	Output - analog signal
	2	AGND	Gnd - analog signal
	3	NC	Do not connect
	4	NC	Do not connect
	5	V+	Input - power supply 24 VDC (±15%)
	6	V0	Gnd - power supply 0 VDC

ELECTRONIC CONNECTIONS - DIGITAL SSI

7 PIN female connector (to solder)	PIN	SIGNAL	NOTES
<p>STCO9131-D07-PG9 (Transducer view)</p>	1	DATA -	Input - serial position data (-)
	2	DATA +	Output - serial position data (+)
	3	CLOCK +	Output - serial synchronous clock (+)
	4	CLOCK -	Input - serial synchronous clock (-)
	5	V+	Input - power supply 24 VDC (±15%)
	6	V0	Gnd - power supply 0 VDC
	7	NC	Do not connect

4 SERVOCYLINDERS TYPE CKM - PROGRAMMABLES
with fieldbus interface PROFIBUS DP or PROFINET

4.1 Working basic principles

CKM servocylinders (see section 3) for magnetosonic working principle) are also available with fieldbus communication interface. Field communication networks allow to exchange a great amount of data among all the devices installed on the machines and industrial plants (servocylinders, valves, pumps, motors, etc.) by means of just one cable. It is so possible to connect all the devices of the system to the machine control unit (fieldbus master) avoiding expensive wirings and start-up costs. Fieldbus provides also a more efficient connection that can speed up the installation task as well as prevent wiring errors. The possibility to perform system level diagnostics on each node or device in the system represents an optimum maintenance tool and it has a positive impact on the system performances. The remarkable aspect of these communication networks is the common standardized language ("interface") of all the connected devices, making the control and monitoring of the whole machine very easy.

4.2 Output signal

The available feedback interface are:

C = PROFINET according to IEC 61158

P = PROFIBUS DP according to EN 50 170 (ISO 74498)

Example of model code: CKM-63/45*0500-X008 -DP-B1X1

Other feedback interface are available on request, contact our technical office.

4.3 Transducer features

CKM are equipped with "MTS"s magnetosonic transducers whose features are shown in the table at side. Other integral position transducers brands are available on request, contact our technical office.

4.4 Electronic connections

Male and female connectors are located on the transducer rear head. The cable connectors are included in the supply:

PROFINET - 3 connectors

- 370523** 5 pin male M12 connector for input and output
- CON-031** 5 pin female M12 connector for power supply

PROFIBUS DP- 4 connectors

- 560884** 5 pin male M12 connector for bus input
- 560885** 5 pin female M12 connector for bus output
- 560888** 5 pin female M12 for bus terminator
- 560886** 4 pin female M8 connector for power supply

See the table at side for electronic connections.. For other connector types, contact our technical office.

4.5 Strokes

From 25 to 3000 mm by increments of 5 mm. If a not standard stroke is required, contact our technical office.

4.6 Cylinder features

See sections 5, 6 and 7 for sizes, mounting style and dimensions. See sections from 18 to 26 for materials and options.

4.7 Fluid requirements

For the suitable fluids and the proper choice of the sealing system, in relation to the fluid characteristics, see sections 25.

Recommended fluid characteristics:
 - Viscosity: 15 ÷ 100 mm²/s
 - Temperature range: 0 ÷ 70°C
 - Fluid contamination class: for normal operation ISO4406 class 18/16/13 NAS1638 class 7. Longer life class 16/14/11 NAS1638 class 5; see also filter section at www.atos.com or KTF catalog.

4.8 Start-up notes

The transducer's fieldbus configuration files and the manual for start-up are included in the supply. The setup of the transducer's slave address is usually done by the bus standard service of the system: if the fieldbus master does not support this service, the setting and diagnostics can be done by a proper wi-fi tool to be separately ordered:

- TL-1-0-EM12** for PROFINET interface
- 252-173-D52** for PROFIBUS DP interface

The sensor electronics case is equipped with two LED that indicate the transducer status, allowing a quick recognition of main possible faults (magnet not detected or out of set-up range). During the start-up it is necessary to bleed off the air from the servocylinder as indicated in section 27. For other details refer to the start-up instructions included in the supply.

4.9 Warnings

Ensure that the servocylinder and wirings are kept away from strong magnetic field and electrical noise to prevent noises on the feedback signal. Check the electronic connections and switch-off the power supply before connecting or disconnecting the position transducer to avoid electronic damages. It is recommended to connect the draining port, supplied as standard, to the tank without back pressure, see section 28 for details.

SERVOCYLINDER TYPE CKM

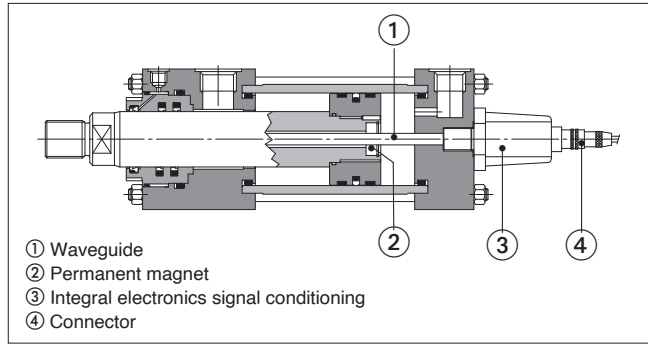

TRANSDUCER FEATURES

Power supply	24 Vdc (±15%)
Data transmission rate (with cable L < 25 m and 1 node)	PROFINET: max. 100 MBit/s PROFIBUS DP: max. 12 MBit/s
Cycle time	1 ms with stroke up to 2000 mm
Resolution	0,5 µm for PROFINET ; 1 µm for PROFIBUS DP
Linearity	<±0,01% F.S. (min ±50 µm)
Repeatability	<±0,001% F.S. (min ±2,5 µm)
Hysteresis	< 4 µm
Temperature coefficient	< 15 ppm/°C
Shock resistance	150g (single hit) / IEC Standard 60068-2-27 for PROFINET 100g (single hit) / IEC Standard 60068-2-27 for PROFIBUS DP
Vibration resistance	15g/10-2000 Hz / IEC Standard 60068-2-6
Overvoltage protection	Up to 36 VDC
Protection degree	IP67 to DIN 40050
Operating temperature	-20 ÷ +85 °C for PROFINET ; 20 ÷ +75 °C for PROFIBUS DP
Measuring range	25 to 3000 mm (increments of 5 mm)
Maximum speed	2 m/s

ELECTRONIC CONNECTIONS - PROFINET

5 PIN female connectors (to screw)	PIN	SIGNAL	NOTES
<p>370523 (D-codec) (Transducer view)</p>	1	Tx (+)	Transmitter
	2	Rx (+)	Receiver
	3	Tx (-)	Transmitter
	4	Rx (-)	Receiver
Housing	SHIELD	Shield	
5 PIN female connector (to solder)			
<p>CON-031 (Transducer view)</p>	1	V+	Input - power supply 24 VDC (±15%)
	2	NC	Do not connect
	3	V0	Gnd - power supply 0 VDC
	4	NC	Do not connect
	5	NC	Do not connect

ELECTRONIC CONNECTIONS - PROFIBUS DP

5 PIN connectors (to screw)	PIN	SIGNAL	NOTES
<p>560884 male 560885 female (Transducer view)</p>	1	+ 5V	for bus termination *
	2	LINE-B	RxD/TxD-N (BUS)
	3	DGND	data line and termination signal zero *
	4	LINE-A	RxD/TxD-P (BUS)
	5	SCHIELD	
4 PIN female connector (to solder)			
<p>560886 (Transducer view)</p>	1	V+	Input - power supply 24 Vdc (±15%)
	2	NC	Do not connect
	3	V0	Gnd - power supply 0 Vdc
	4	NC	Do not connect

* Female only

5 INSTALLATION DIMENSIONS [mm] FOR SERVOCLINDERS TYPE CKF, CKM

Ø Bore	40	50	63	80	100	125	160	200
Ø Rod	28	36	45	56	70	90	110	140
A max	28	36	45	56	63	85	95	112
A1 (option H) max	18	22	28	36	45	56	63	85
AA	59	74	91	117	137	178	219	269
B f9	42	50	60	72	88	108	133	163
BB +3/0	35	46	46	59	59	81	92	115
BG min	12	18	18	24	24	27	32	40
CH h14	22	30	39	48	62	80	100	128
CO N9	12	12	16	16	16	20	30	40
DD 6g	M8x1	M12x1,25	M12x1,25	M16x1,25	M16x1,25	M22x1,5	M27x2	M30x2
D (1)	25	29	29	36	36	42	42	52
D1 (1)	29	NA	NA	42	42	52	52	58
E	63±1,5	75±1,5	90±1,5	115±1,5	130±2	165±2	205±2	245±2
EE (1) 6g	G 3/8	G 1/2	G 1/2	G 3/4	G 3/4	G 1	G 1	G 1 1/4
EE1(1) 6g	G 1/2	NA	NA	G 1	G 1	G1 1/4	G1 1/4	G 1 1/2
F max	10	16	16	20	22	22	25	25
FB H13	11	14	14	18	18	22	26	33
J	38	38	38	45	45	58	58	76
KC min	4	4,5	4,5	5	6	6	8	8
KK standard 6g	M20 x 1,5	M27 x 2	M33 x 2	M42 x 2	M48 x 2	M64 x 3	M80 x 3	M100 x 3
KK1 option H 6g	M14 x 1,5	M16 x 1,5	M20 x 1,5	M27 x 2	M33 x 2	M42 x 2	M48 x 2	M64 x 3
LH h10	31	37	44	57	63	82	101	122
PJ ±1,5 (3)	85	74	80	93	101	117	130	165
PJ1 ±1,5 (1) (3)	87,5	NA	NA	93	99	121	143	167
R js13	41	52	65	83	97	126	155	190
RD f8	62	74	88	105	125	150	170	210
RT	M8x1,25	M12x1,75	M12x1,75	M16x2	M16x2	M22x2,5	M27x3	M30x3,5
SB H13	11	14	18	18	26	26	33	39
SS ±1,25 (3)	109	91	85	104	101	130	129	171
ST js13	12,5	19	26	26	32	32	38	44
TC h14	63	76	89	114	127	165	203	241
TD f8	20	25	32	40	50	63	80	100
TG js13	41,7	52,3	64,3	82,7	96,9	125,9	154,9	190,2
TL js13	16	20	25	32	40	50	63	80
TM h14	76	89	100	127	140	178	215	279
TO js13	87	105	117	149	162	208	253	300
TS js13	83	102	124	149	172	210	260	311
UM	108	129	150	191	220	278	341	439
UO max	110	130	145	180	200	250	300	360
US max	103	127	161	186	216	254	318	381
UT	95	116	139	178	207	265	329	401
UW max	70	88	98	127	141	168	215	269
VD	12	9	13	9	10	7	7	7
VE max	22	25	29	29	32	29	32	32
VL min	3	4	4	4	5	5	5	5
WF ±2	35	41	48	51	57	57	57	57
WH ±2	25	25	32	31	35	35	32	32
XG ±2 (3)	57	64	70	76	71	75	75	85
XS ±2 (3)	45	54	65	68	79	79	86	92
XV (2)	Minimum stroke	5	15	20	20	35	35	35
	min	100	109	120	129	148	155	161
±2 (3)	max	99+stroke	98+stroke	100+stroke	115+stroke	117+stroke	134+stroke	141+stroke
Y ±2	62	67	71	77	82	86	86	98
Y1 ±2 (1)	61,5	NA	NA	75,5	83	84	79,5	97
ZB max	178	184	192	212	225	260	279	336

NOTES TO TABLE

(1) Oil ports are threaded according to ISO 1179-1 (GAS standards) with counterbore dimension D. When oversized oil ports are selected, dimensions **D**, **EE**, **PJ** and **Y** are respectively modified into **D1**, **EE1**, **PJ1** and **Y1**. For bore 160 with mounting styles E, N the dimension **PJ1** reported in the table is modified, contact our technical office.

(2) **XV** - For cylinders with mounting style **L** the stroke must always exceed the minimum values reported in the table. The requested **XV** value must be included between **XV min** and **XV max** and it must be always indicated, with dimension in millimeters, together with the cylinder code. See the following example:

CKM-50/36*0500-L208 - D - B1E3X1 **XV = 200**

(3) The tolerance is valid for strokes up to 1250 mm, for longer strokes the upper tolerance is the max stroke tolerance reported in section [18].

6 BASIC CONFIGURATION

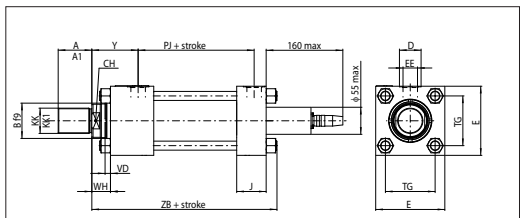

Basic configuration: X - see section [6] for dimensions

7 MOUNTING STYLE FOR SERVOCYLINDERS TYPE CKF, CKM

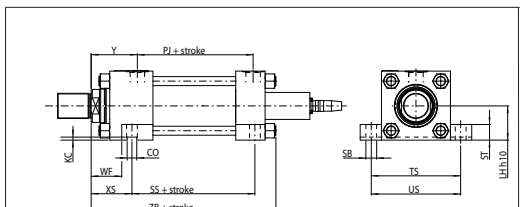

E (ISO MS2) = feet

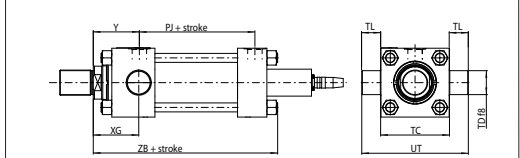

G (ISO MT1) = front trunnion

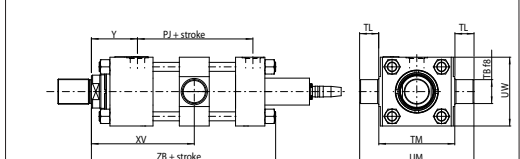

L (ISO MT4) = intermediate trunnion

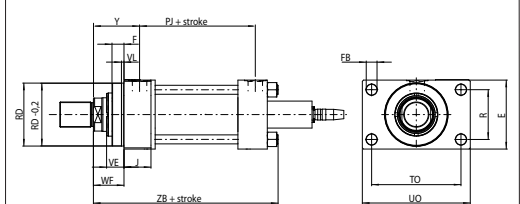

N (ISO ME5) = front flange

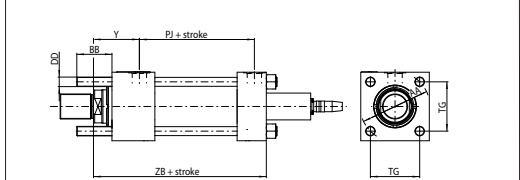

Y (ISO MX3) = front tie rods extended

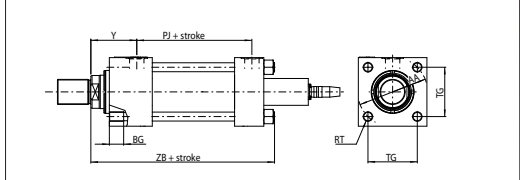

Z (ISO MX5) = front threaded holes

8 SERVOCYLINDERS TYPE CKN

8.1 Magnetostrictive transducers - basic working principles

The magnetostrictive transducer is composed by: a waveguide element ① fixed to the cylinder's body, a permanent magnet ② rigidly connected to the cylinder's rod and an integral electronics signal conditioning ③ located inside the rear head.

The position measurement is based upon the magnetostriction phenomenon: the electronics signal conditioning ③ generates a short current pulse that travels through the waveguide ①. When this pulse meets the magnetic field of the permanent magnet ②, a torsional wave is generated and it travels back to the electronics signal conditioning.

The position of the moving magnet is thus accurately determined by measuring the elapsed time between the application of the current pulse and the arrival of the torsional wave, thanks to their constant ultrasonic speed. Sensor electronics signal conditioning transforms this measurement into the analogic output feedback signal.

The contactless construction of the position transducer ensures a long working life and allows its use even in hard environmental conditions (shocks, vibrations etc.) or high working frequencies.

The small size of this magnetostrictive transducer allows the installation completely inside the cylinder, providing a very compact construction and a reduction of the overall dimensions respect to CKF and CKM servocylinders. These features make CKN servocylinders the best alternative to external absolute encoders, potentiometric and inductive transducers.

8.2 Output signal

The transducer integral electronics is available with the following configurations:

Analog

A = 4 - 20 mA

V = 0,1 - 10,1 V (0 - 10 V with electronic conditioning card)

The option **A** or **V** for the output signal has to be always entered in the cylinder code.

Transducer's performance can be enhanced with the optional electronic conditioning card, option **N**, which allows to adjust zero and gain references by a "magnetic pen" included in the supply.

Example of model code for CKN with electronic conditioning card and current output:

CKN-63/45*0500-X008 -AN-B1X1

8.3 Transducer features

CKN are equipped with "GEFRAN"'s magnetostrictive transducers whose features are shown in the tables at side.

8.4 Electronic connections

The 6 pin male connector M16 is mounted on side 4 of the cylinder rear head. The electronic conditioning card (option **N**) has to be connected to the transducer by wire clamp IP67 and screw terminals.

The straight female cable connector ④ **STCO9131-D06-PG7** is included in the supply, for option **N** the connector is supplied with a cable 3 m long connected to the electronic conditioning card. The 90° female connector **STCO9131-6-PG7** can be supplied selecting option **M**. See the table at side for electronic connections. The 5 pin male connector M12 allows the connection of the electronic conditioning card to the control system, the straight female connector M12 5 pin **CON031** is included in the supply.

8.5 Strokes

From 100 to 3000 mm by increments of 100 mm.

If a not standard stroke is required, contact our technical office.

8.6 Cylinder features

See sections ⑨, ⑩ and ⑪ for sizes, mounting style and dimensions.

See sections from ⑫ to ⑮ for materials and options.

8.7 Fluid requirements

CKN servocylinders are suitable for operation with mineral oils with or without additives (**HH, HL, HLP, HLP-D, HM, HV**), fire resistant fluids (**HFA** oil in water emulsion - 90-95% water and 5-10% oil, **HFB** water in oil emulsion - 40% water, **HFC** water glycol - max 45% water) and synthetic fluids (**HFD-U** organic esters, **HFD-R** phosphate esters).

For the proper choice of the sealing system, in relation to the fluid characteristics, see section ⑮.

Recommended fluid characteristics:

- Viscosity: 15 ÷ 100 mm²/s

- Temperature range: 0 ÷ 70°C

- Fluid contamination class: for normal operation ISO4406 class 18/16/13 NAS1638 class 7. Longer life class 16/14/11 NAS1638 class 5; see also filter section at www.atos.com or KTF catalog.

8.8 Start-up notes

CKN servocylinders are supplied with the zero/span values adjusted to the cylinder's mechanical stroke ends.

During the start-up it is necessary to bleed off the air from the servocylinder as indicated in section ⑰.

For other details refer to the start-up instructions included in the supply.

8.9 Warnings

Ensure that the servocylinder and wirings are kept away from strong magnetic field and electrical noise to prevent noises on the feedback signal. Check the electronic connections and switch-off the power supply before wiring, connecting or disconnecting the position transducer to avoid electronic damages. Ensure that the maximum distance between the servocylinder and the electronic conditioning card is lower than the recommended one: 50 m.

It is recommended to connect the draining port, supplied as standard, to the tank without back pressure, see section ⑱ for details.

SERVOCYLINDER TYPE CKN

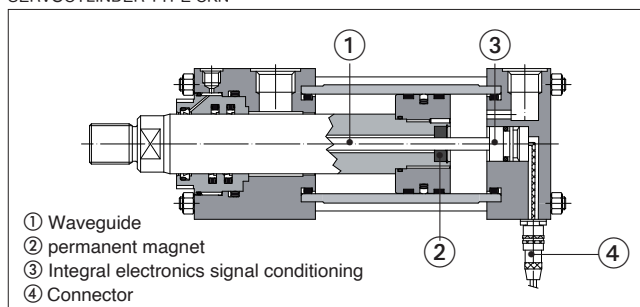

TRANSDUCER FEATURES

Power supply	18 - 30 Vdc (±15%)
Output signal	0,1 ÷ 10,1 Vdc / 4 ÷ 20 mA
Resolution	infinite, restricted by the output ripple
Linearity	< ± 0,02% F.S (min ± 60 μm)
Repeatability	< ± 0,01 mm (hysteresis < ± 0,005 % F.S.)
Cycle time	1 ms (1,5 for 1100 < strokes < 2000 ; 2 for strokes > 2000 mm)
Temperature coefficient	50 ppm/°C
Operating temperature	-20 ÷ +90°C (+70°C for strokes > 2500 mm)
Connection type	6 pin connector M16 to DIN 45322
Protection degree	IP67 to DIN 40050
Shock resistance	100g (single hit) / IEC Standard 60068-2-27
Vibration resistance	20g / 10÷2000 Hz / IEC Standard 60068-2-6
Measuring range	100 to 3000 mm (increments of 100 mm)
Maximum speed	1 m/s

ELECTRONIC CONNECTIONS - OPTION A,V

6 PIN female connector (to solder)	PIN	SIGNAL	NOTES
 STCO9131-D06-PG7 (Transducer view)	1	V+	Input - power supply 24 VDC (±15%)
	2	V0	Gnd - power supply 0 VDC
	3	OUTPUT	Output - analog signal
	4	AGND	Gnd - analog signal
	5	NC	Not connect
	6	NC	Not connect

ELECTRONIC CONDITIONING CARD - OPTION N

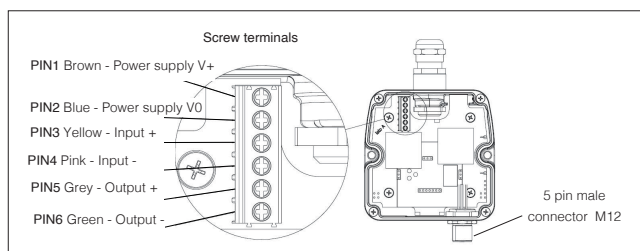

5 PIN female connector (to solder)	PIN	SIGNAL	NOTES
 CON031 (Transducer view)	1	OUTPUT1	Output - analog signal
	2	AGND	Gnd - analog signal
	3	OUTPUT2	Output2 - analog signal
	4	V0	Gnd - power supply 0 VDC
	5	V+	Input - power supply 24 VDC (±15%)

ELECTRONIC CONDITIONING CARD FEATURES

	Current output A	Voltage output V
Output	4±20 mA	0÷10 Vdc
Output load	< 500 Ω	2 kΩ
Max output value	25 mA	10,6 V
Output ripple	< 5 mV pp	
Supply voltage	from 10 to 30 Vdc	
Resolution	16 bit	
Speed calculation time	sampling time +500 μ s	
Operating temperature	0 ÷ +70°C (storage -40 ÷ +85°C)	

9 INSTALLATION DIMENSIONS [mm] FOR SERVOCYLINDERS TYPE CKN

Ø Bore	40	50	63	80	100	125	160	200	
Ø Rod	28	36	45	56	70	90	110	140	
A max	28	36	45	56	63	85	95	112	
A1 option H max	NA	NA	NA	36	45	56	63	85	
AA ref	59	74	91	117	137	178	219	269	
B f9	42	50	60	72	88	108	133	163	
BB +3/0	35	46	46	59	59	81	92	115	
BG min	12	18	18	24	24	27	32	40	
CB A16	20	30	30	40	50	60	70	80	
CD H9	14	20	20	28	36	45	56	70	
CF max	42	62	62	83	103	123	143	163	
CH h14	22	30	39	48	62	80	100	128	
CO N9	12	12	16	16	16	20	30	40	
CX	value	20	25	30	40	50	60	80	100
	tolerance	0 -0,012			0 -0,015			0 -0,02	
D (1)	25	29	29	36	36	42	42	52	
DD	M8x1	M12x1,25	M12x1,25	M16x1,25	M16x1,25	M22x1,5	M27x2	M30x2	
E	63±1,5	75±1,5	90±1,5	115±1,5	130±2	165±2	205±2	245±2	
EE (1) 6g	G 3/8	G 1/2	G 1/2	G 3/4	G 3/4	G 1	G 1	G 1 1/4	
EP max	13	17	19	23	30	38	47	57	
EW h14	20	30	30	40	50	60	70	80	
EX	16 0/-0,12	20 0/-0,12	22 0/-0,12	28 0/-0,12	35 0/-0,12	44 0/-0,15	55 0/-0,15	70 0/-0,2	
F max	10	16	16	20	22	22	25	25	
FB H13	11	14	14	18	18	22	26	33	
J ref	38	38	38	45	45	58	58	76	
KC min	4	4,5	4,5	5	6	6	8	8	
KK 6g	M20x1,5	M27x2	M33x2	M42x2	M48x2	M64x3	M80x3	M100x3	
KK1 option H 6g	M14x1,5	M16x1,5	M20x1,5	M27x2	M33x2	M42x2	M48x2	M64x2	
L min	19	32	32	39	54	57	63	82	
LH h10	31	37	44	57	63	82	101	122	
LT min	25	31	38	48	58	72	92	116	
MR max	17	29	29	34	50	53	59	78	
MS max	29	33	40	50	62	80	100	120	
PJ ±1,5 (3)	85	74	80	143	151	167	180	190	
R js13	41	52	65	83	97	126	155	190	
RD f8	62	74	88	105	125	150	170	210	
RT	M8x1,25	M12x1,75	M12x1,75	M16x2	M16x2	M22x2,5	M27x3	M30x3,5	
SB H13	11	14	18	18	26	26	33	39	
SS ±1,25 (3)	109	91	85	154	151	180	179	196	
ST js13	12,5	19	26	26	32	32	38	44	
TC h14	63	76	89	114	127	165	203	241	
TD f8	20	25	32	40	50	63	80	100	
TG js13	41,7	52,3	64,3	82,7	96,9	125,9	154,9	190,2	
TL js13	16	20	25	32	40	50	63	80	
TM h14	76	89	100	127	140	178	215	279	
TO js13	87	105	117	149	162	208	253	300	
TS js13	83	102	124	149	172	210	260	311	
UM ref	108	129	150	191	220	278	341	439	
UO max	110	130	145	180	200	250	300	360	
US max	103	127	161	186	216	254	318	381	
UT ref	95	116	139	178	207	265	329	401	
UW max	70	88	98	127	141	168	205	269	
VD	12	9	13	9	10	7	7	7	
VE max	22	25	29	29	32	29	32	32	
VL min	3	4	4	4	5	5	5	5	
WF ±2	35	41	48	51	57	57	57	57	
WH ±2	25	25	32	31	35	35	32	32	
XC ±1,5 (3)	237	256	265	279	307	339	358	406	
XG ±2 (3)	57	64	70	76	71	75	75	85	
XO ±1,5 (3)	243	255	271	288	311	354	387	440	
XS ±2 (3)	45	54	65	68	79	79	86	92	
XV (2)	Minimum stroke	5	15	20	20	35	35	35	
	min	100	109	120	129	148	155	161	
±2 (3)	max	99+stroke	98+stroke	100+stroke	115+stroke	117+stroke	134+stroke	141+stroke	
Y ±2	62	67	71	77	82	86	86	98	
ZB max	231	241	250	262	275	310	329	361	
ZJ ±1 (3)	218	224	233	240	253	282	295	324	

NOTES TO TABLE

- Oil ports with dimension EE are threaded according to ISO 1179-1 (GAS standards) with counterbore dimension D.
- XV** - For cylinders with mounting style **L** the stroke must always exceed the minimum values reported in the table. The requested XV value must be included between **XV min** and **XV max** and it must be always indicated, with dimension in millimeters, together with the cylinder code. See the following example:
CKN-50/36°0500-L208 - AK - B1E3X1 **XV = 200**
- The tolerance is valid for strokes up to 1250 mm, for longer strokes the upper tolerance is the max stroke tolerance reported in section 18.

10 BASIC CONFIGURATION

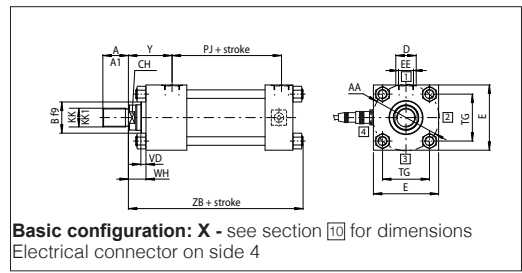

11 MOUNTING STYLES FOR SERVOCYLINDERS TYPE CKN

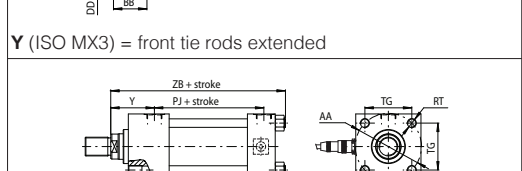
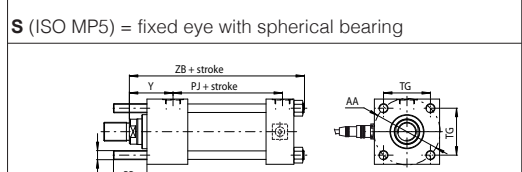
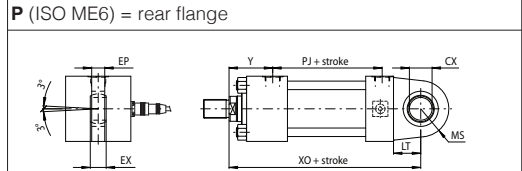
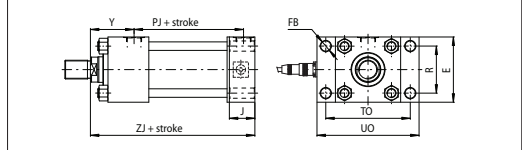
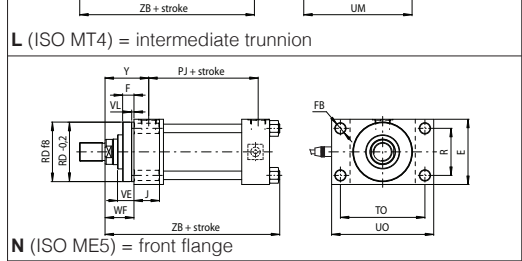
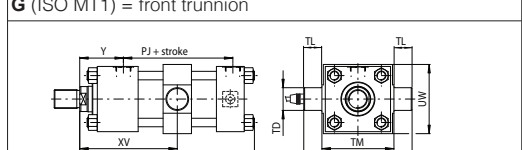
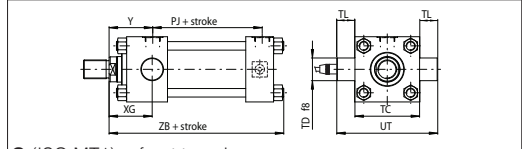
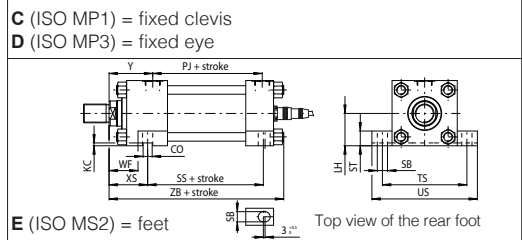
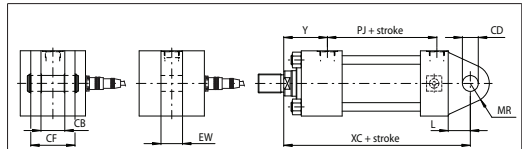

12 SERVOCYLINDERS TYPE CKP

12.1 Potentiometric transducers - basic working principles

The potentiometric transducer is composed by two resistive tracks ① and a wiper ② which realizes the sliding contact through two metallic brushes. The resistive track is an aluminium element with a conductive plastic coating fixed to the cylinder's rear head. The wiper is mounted on the piston rod and moves together with it.

The tracks of the potentiometer have to be connected to a stabilized DC voltage to allow a small current flow. The two brushes of the wiper close the electronic circuit with the tracks (see figure at side), changing the resistance value and thus the voltage output proportionally to the rod position (principle of potential divider).

CKP servocylinders present the best price/performance ratio. Their compact construction allows the easy application of servocylinders in place of a standard cylinders without transducer.

12.2 Transducer features

For all the transducer features see the table at side.

12.3 Electronic connections

The 4 pin male connector is mounted on side 4 of the cylinder rear head for all mounting styles except style E (ISO MS2), where it is mounted along the cylinder axis, see section 16.

The straight female cable connector ③ STCO9131-D04-PG7 is included in the supply. The 90° female connector STCO9131-4-PG7 can be supplied selecting option M.

See the table at side for electronic connections.

12.4 Strokes

From 100 to 700 mm by increments of 100 mm.

If a not standard stroke is required, contact our technical office.

12.5 Cylinder features

See sections 14, 15 and 16 for sizes, mounting style and dimensions.

See sections from 18 to 26 for materials and options.

12.6 Fluids requirements

CKP servocylinders are suitable for operation with mineral oils with or without additives (HH, HL, HLP, HLP-D, HM, HV) **not compatible with glycol water and water based fluids.**

For the proper choice of the sealing system, in relation to the fluid characteristics, see section 25.

Recommended fluid characteristics:

- Viscosity: 15 ÷ 100 mm²/s

- Temperature range: 0 ÷ 70°C

- Fluid contamination class: for normal operation ISO4406 class 18/16/13 NAS1638 class 7. Longer life class 16/14/11 NAS1638 class 5; see also filter section at www.atos.com or KTF catalog.

12.7 Start-up notes

During the start-up it is necessary to bleed off the air from the servocylinder. The air bleed is located on the rod end, see figure at side.

For a proper use of the air-bleed unlock the grub screw ④ M8 x 10 with a wrench for hexagonal head screws, moves the cylinder for the necessary cycles to bleed-off the air and retighten by a torque of 20 Nm.

Take care to completely bleed off the air from the inside because the compressibility effects of the air trapped-in may compromise the contact between the brushes and the resistive tracks.

Ensure to bleed off the air after every long time stop of the servocylinder.

For other details refer to the start-up instructions included in the supply.

12.8 Warnings

For a correct functioning, the transducer must be exclusively used as a potential divider.

Ensure to observe the maximum rating power indicated in the table "transducer features" to avoid any component damage.

The power supply must be stabilized: variations on the voltage provided have direct influence on the output values.

It is recommended to connect the draining port, supplied as standard, to the tank without back pressure, see section 26 for details.

SERVOCYLINDER TYPE CKP

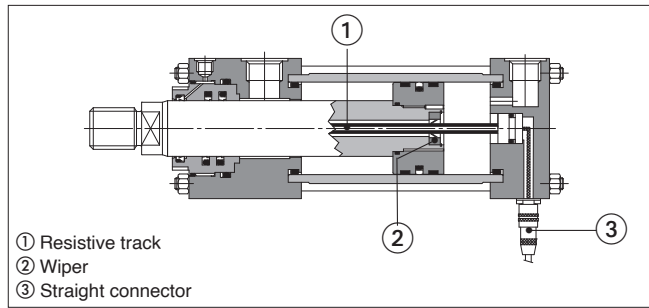

ELECTRONIC CIRCUIT

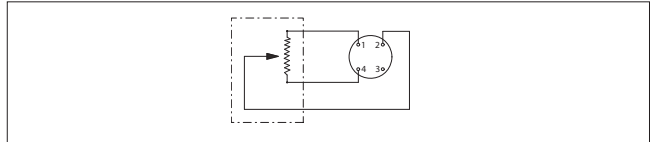

TRANSDUCER FEATURES

Supply reference	10 Vdc recommended (max 30 Vdc)
Dissipation	3 W at 40°C, 0 W at 120°C
Linearity	±0,1% F.S.
Repeatability	0,01 mm
Total resistance	10 kΩ at full stroke
Insulation resistance	> 100 MΩ to 500 Vdc
Wiper current	Recommended: a few μA (10mA max)
Temperature limits	-20 ÷ + 100°C
Connection type	4 pin connector to Mil-C-26482
Protection degree	IP67 to DIN 40050
Measuring range	100 to 700 mm (increments of 100 mm)
Maximum speed	0,5 m/s

ELECTRONIC CONNECTIONS

4 PIN female connector (to solder)	PIN	SIGNAL	NOTES
 STCO9131-D04-PG7 (Transducer view)	1	V0	Gnd - power supply 0 Vdc
	2	OUTPUT	Output - 0 - 10 V
	3	NC	Do not connect
	4	Vref	Input - power supply 10 VDC

ROD AIR BLEED

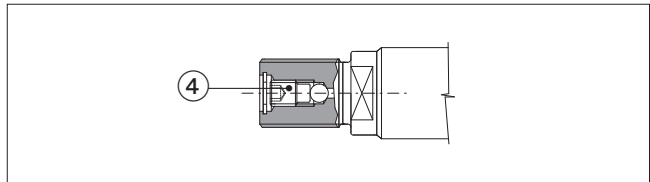

13 SERVOCYLINDERS TYPE CKV

13.1 Inductive transducers - basic working principles

The transducer is composed by a single coil-winding ① and a ferromagnetic core ②. The coil-winding is integrated into a tube fixed to the cylinder's rear head, the core is fixed to the piston rod and moves together with it.

When the core moves together with the piston, the inductance of the coil-winding changes proportionally to the core position. The separate electronic conditioning card sends a sinusoidal signal to the primary coil-winding, it reads the corresponding signal of the secondary coil-winding and, from their difference, it calculates the inductance and computes the analog output feedback signal.

The contactless principle of the transducer ensures a long working life and its ruggedness construction allows to withstand high frequencies or dynamical stresses (i.e. simulators, vibropresses etc.).

The compact construction of CKV allows the easy application of the servocylinders in place of cylinders without transducer.

The separate conditioning card makes the inductive transducer ideal for all applications with high temperatures: in this case the max temperature is limited by the sealing system.

13.2 Transducer features

CKV are equipped with "Penny & Giles"'s ICT inductive transducers whose features are shown in the table at side.

The performances of the transducer indicated in the table at side refer exclusively to the use with its proper conditioning card.

13.3 Electronic conditioning card

In order to grant the performance in the table at side, it is mandatory to purchase the electronic conditioning card with one of the two following configurations:

A = 4 - 20 mA

V = 0 - 10 V

Other output ranges are available on request, contact our technical office.

The electronic conditioning card allows to adjust the zero and gain references by a screwdriver.

The card format fits to DIN EN50022 or EN50035 rails or allows a wall mounting by 4 screws M5x30.

13.4 Electronic connections

The 4 pin male connector is mounted on side 4 of the cylinder rear head for all mounting styles except style E (ISO MS2), where it is mounted along the cylinder's axis, see section 16.

The straight female cable connector ③ **STCO9131-D04-PG7** is supplied with a cable 3 m long connected to the electronic conditioning card by wire clamp IP66 and screw terminals. The 90° female connector **STCO9131-4-PG7** can be supplied selecting option **M**.

See the table at side for electronic connections.

13.5 Strokes

From 30 to 1000 mm by increments of 10 mm.

If a not standard stroke is required, contact our technical office.

13.6 Cylinder features

See sections 14, 15 and 16 for sizes, mounting style and dimensions.

See sections from 18 to 26 for materials and options.

13.7 Fluid requirements

CKV servocylinders are suitable for operation with mineral oils with or without additives (**HH, HL, HLP, HLP-D, HM, HV**), fire resistant fluids (**HFA** oil in water emulsion - 90-95% water and 5-10% oil, **HFB** water in oil emulsion - 40% water, **HFC** water glycol - max 45% water) and synthetic fluids (**HFD-U** organic esters, **HFD-R** phosphate esters).

For the proper choice of the sealing system, in relation to the fluid characteristics, see section 25.

Recommended fluid characteristics:

- Viscosity: 15 ÷ 100 mm²/s

- Temperature range: 0 ÷ 70°C

- Fluid contamination class: for normal operation ISO4406 class 18/16/13 NAS1638 class 7. Longer life class 16/14/11 NAS1638 class 5; see also filter section at www.atos.com or KTF catalog.

13.8 Start-up notes

CKV servocylinders are supplied with zero/span values adjusted to the cylinder's mechanical stroke ends. During the start-up it is necessary to bleed off the air from the servocylinder as indicated in section 27.

For other details refer to the start-up instructions included in the supply.

13.9 Warnings

Ensure that the maximum distance between the servocylinder and the conditioning card is lower than the recommended one: 10 m.

It is recommended to connect the draining port, supplied as standard, to the tank without back pressure, see section 28 for details.

SERVOCYLINDER TYPE CKV

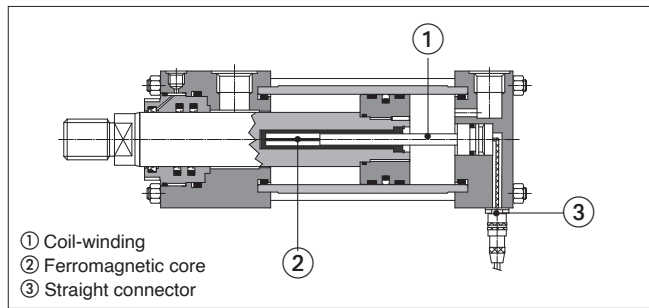

- ① Coil-winding
- ② Ferromagnetic core
- ③ Straight connector

TRANSDUCER FEATURES

Linearity	±0,2%
Repeatability	±0,05 %
Insulation resistance	>50 MΩ to 50 Vdc
Temperature coefficient	±200 ppm/°C from -20 to +100°C
Operating temperature	-20 ÷ +120°C
Connection type	4 pin connector to Mil-C-26482
Protection degree	IP67 to DIN 40050
Measuring range	30 to 1000 mm (increments of 10 mm)
Maximum speed	1 m/s

ELECTRONIC CONNECTIONS

4 PIN female connector (to solder)	PIN	SIGNAL	NOTES
<p>STCO9131-D04-PG7 (Transducer view)</p>	1	Ve+	Coil V+
	2	Ve-	Coil V-
	3	NC	Do not connect
	4	V0	Sensor ground

ELECTRONIC CONDITIONING CARD

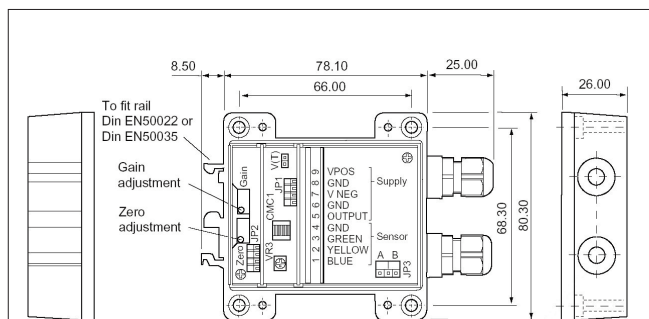

	Analog output A	Voltage output V
Supply voltage	from 10 to 30 Vdc	from 13,5 to 30 Vdc
Supply current	12,6 mA max	19 mA max
Output	4÷20 mA	0÷10 Vdc
Zero adjustment range	-10% to +60% of span	
Gain adjustment range	+40% to +110% of span	
Output ripple	< 5 mV rms	
Output load	10 kΩ min.	
Operating temperature	0 ÷ +70°C (storage -40 ÷ +85°C)	
Temperature coefficient	300 ppm/°C	
Protection degree	IP66 to DIN 40050	

14 INSTALLATION DIMENSIONS [mm] FOR SERVOCYLINDERS TYPE CKP, CKV

Ø Bore	40	50	63	80	100	125	160	200	
Ø Rod	28	36	45	56	70	90	110	140	
A max	28	36	45	56	63	85	95	112	
A1 option H max	NA	NA	NA	36	45	56	63	85	
AA ref	59	74	91	117	137	178	219	269	
B f9	42	50	60	72	88	108	133	163	
BB +3/0	35	46	46	59	59	81	92	115	
BG min	12	18	18	24	24	27	32	40	
CB A16	20	30	30	40	50	60	70	80	
CD H9	14	20	20	28	36	45	56	70	
CF max	42	62	62	83	103	123	143	163	
CH h14	22	30	39	48	62	80	100	128	
CO N9	12	12	16	16	16	20	30	40	
CX	value	20	25	30	40	50	60	80	100
	tolerance	0 -0,012				0 -0,015		0 -0,02	
D (1)	25	29	29	36	36	42	42	52	
DD 6g	M8x1	M12x1,25	M12x1,25	M16x1,25	M16x1,25	M22x1,5	M27x2	M30x2	
E	63±1,5	75±1,5	90±1,5	115±1,5	130±2	165±2	205±2	245±2	
EE (1) 6g	G 3/8	G 1/2	G 1/2	G 3/4	G 3/4	G 1	G 1	G 1 1/4	
EP max	13	17	19	23	30	38	47	57	
EW h14	20	30	30	40	50	60	70	80	
EX	16 0/-0,12	20 0/-0,12	22 0/-0,12	28 0/-0,12	35 0/-0,12	44 0/-0,15	55 0/-0,15	70 0/-0,2	
F max	10	16	16	20	22	22	25	25	
FB H13	11	14	14	18	18	22	26	33	
J ref	38	38	38	45	45	58	58	76	
KC min	4	4,5	4,5	5	6	6	8	8	
KK 6g	M20x1,5	M27x2	M33x2	M42x2	M48x2	M64x3	M80x3	M100x3	
KK1 option H 6g	M14x1,5	M16x1,5	M20x1,5	M27x2	M33x2	M42x2	M48x2	M64x2	
L min	19	32	32	39	54	57	63	82	
LH h10	31	37	44	57	63	82	101	122	
LT min	25	31	38	48	58	72	92	116	
MR max	17	29	29	34	50	53	59	78	
MS max	29	33	40	50	62	80	100	120	
PJ ±1,5 (3)	85	74	80	93	101	117	130	165	
R js13	41	52	65	83	97	126	155	190	
RD f8	62	74	88	105	125	150	170	210	
RT	M8x1,25	M12x1,75	M12x1,75	M16x2	M16x2	M22x2,5	M27x3	M30x3,5	
SB H13	11	14	18	18	26	26	33	39	
SS ±1,25 (3)	109	91	85	104	101	130	129	171	
ST js13	12,5	19	26	26	32	32	38	44	
TC h14	63	76	89	114	127	165	203	241	
TD f8	20	25	32	40	50	63	80	100	
TG js13	41,7	52,3	64,3	82,7	96,9	125,9	154,9	190,2	
TL js13	16	20	25	32	40	50	63	80	
TM h14	76	89	100	127	140	178	215	279	
TO js13	87	105	117	149	162	208	253	300	
TS js13	83	102	124	149	172	210	260	311	
UM ref	108	129	150	191	220	278	341	439	
UO max	110	130	145	180	200	250	300	360	
US max	103	127	161	186	216	254	318	381	
UT ref	95	116	139	178	207	265	329	401	
UW max	70	88	98	127	141	168	205	269	
VD	12	9	13	9	10	7	7	7	
VE max	22	25	29	29	32	29	32	32	
VL min	3	4	4	4	5	5	5	5	
WF ±2	35	41	48	51	57	57	57	57	
WH ±2	25	25	32	31	35	35	32	32	
XC ±1,5 (3)	184	191	200	229	257	289	308	381	
XG ±2 (3)	57	64	70	76	71	75	75	85	
XO ±1,5 (3)	190	190	206	238	261	304	337	415	
XS ±2 (3)	45	54	65	68	79	79	86	92	
XV (2)	Minimum stroke	5	15	20	20	35	35	35	35
	min	100	109	120	129	148	155	161	195
±2 (3)	max	99+stroke	98+stroke	100+stroke	115+stroke	117+stroke	134+stroke	141+stroke	166+stroke
Y ±2	62	67	71	77	82	86	86	98	
ZB max	178	176	185	212	225	260	279	336	
ZJ	165	159	168	190	203	232	245	299	

NOTES TO TABLE

- (1) Oil ports with dimension EE are threaded according to ISO 1179-1 (GAS standards) with counterbore dimension D.
- (2) **XV** - For cylinders with mounting style **L** the stroke must always exceed the minimum values reported in the table. The requested XV value must be included between **XV min** and **XV max** and it must be always indicated, with dimension in millimeters, together with the cylinder code. See the following example:
CKP-50/36*0500-L208 - K - B1E3X1 **XV = 200**
- (3) The tolerance is valid for strokes up to 1250 mm, for longer strokes the upper tolerance is the max stroke tolerance reported in section 18.

15 BASIC CONFIGURATION

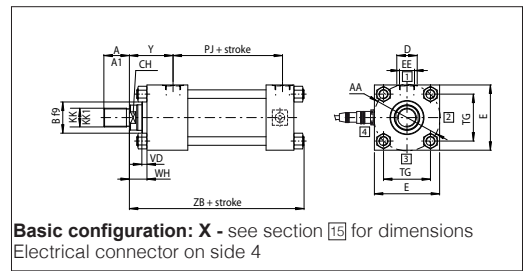

16 MOUNTING STYLES FOR SERVOCYLINDERS TYPE CKP, CKV

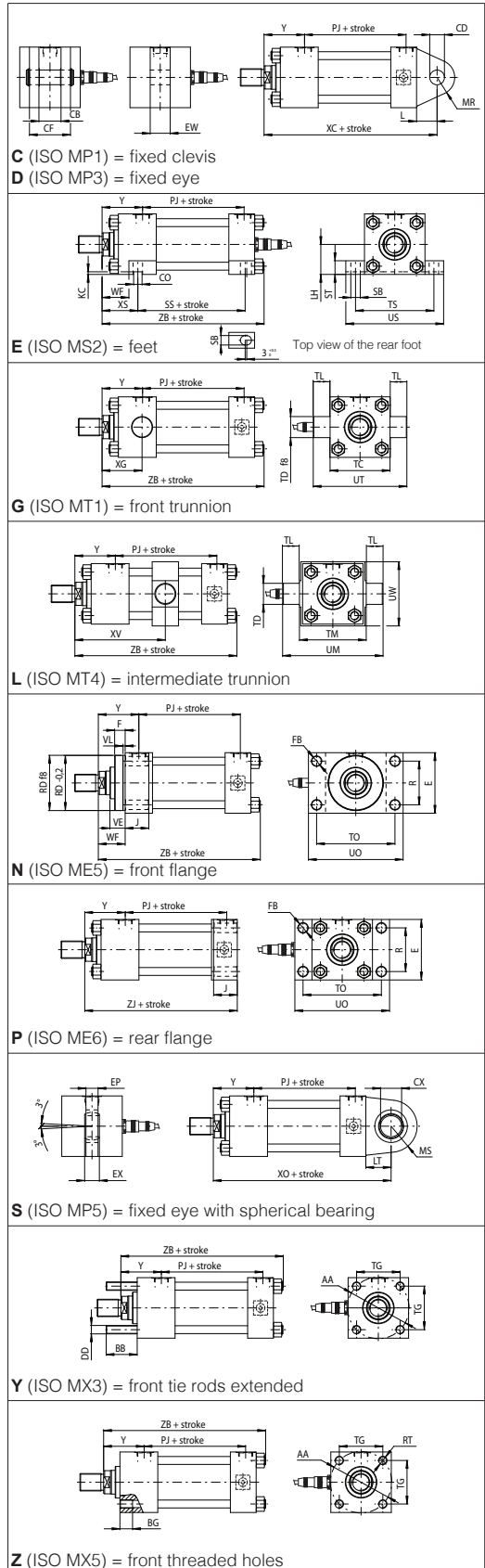

17 MAIN CHARACTERISTICS OF TRANSDUCERS

Code	CKF section [2]	CKM section [3]	CKN section [8]	CKP section [12]	CKV section [13]
Transducer type	Magnetosonic, analog	Magnetosonic, programmable	Magnetostrictive	Potentiometric	Inductive
Linearity error (1)	< ± 0,02%	< ± 0,01%	< ± 0,02%	± 0,1%	± 0,2%
Repeatability	< ± 0,001% (1)	< ± 0,001% (1)	< ± 0,005% (1)	0,01 mm	± 0,05% (1)
Strokes	50 to 2500	25 to 3000	100 to 3000	100 to 700	30 to 1000
Interface	Analog: 0 ÷ 10 V, 4 ÷ 20 mA Digital: SSI	Analog: 0 ÷ 10V, 4 ÷ 20 mA Digital: SSI, PROFINET, PROFIBUS DP	Voltage: 0,1 ÷ 10,1 V Current: 4 ÷ 20 mA	Voltage 0 ÷ 10 V	Voltage: 0 ÷ 10 V Current: 4 ÷ 20 mA
Typical applications	Sawing or bending machines	Steel plants, plastic and rubber	Foundry and energy	Various	Simulators and energy
Temperature limits	-20°C to +75°C	-20°C to +75°C	-20°C to +90°C	-20°C to +100°C	-20°C to +120°C

(1) Percentage of the total stroke

18 STROKE SELECTION

Stroke has to be selected a few mm longer than the working stroke to prevent the use of the cylinder heads as mechanical stroke-end. The stroke tolerances are reported in the table at side.

19 SPACER

For strokes longer than 1000 mm, proper spacers have to be introduced in the cylinder's construction to increase the rod and piston guide and to protect them from overloads and premature wear. Spacers can be omitted for cylinders working in traction mode. The introduction of spacers increases the overall cylinder's dimensions: spacers' length has to be added to all stroke dependent dimensions in sections [5], [9] and [14].

20 CYLINDER'S HOUSING FEATURES

The cylinder's housings are made in "cold drawn and stressed steel"; the internal surfaces are lapped: diameter tolerance H8, roughness Ra ≤ 0,25 µm.

21 TIE RODS FEATURES

The cylinder's tie rods are made in "normalized automatic steel"; end-threads are rolled to improve the fatigue working life. They are screwed to the heads or mounted by means of nuts with a prefixed tightening torque MT, see the table at side.

22 RODS FEATURES and options

The rods materials have high strength, which provide safety coefficients higher than 4 in static stress conditions, at maximum working pressure. The rod surface is chrome plated: diameter tolerances f7; roughness Ra ≤ 0,25 µm. Corrosion resistance of 100 h in neutral spray to ISO 9227 NSS

ø Rod	Material	Rs min [N/mm ²]	Chrome	
			min. thickness [mm]	hardness [HV]
28÷90	hardened and tempered alloy-steel	700	0,020	850-1150
110÷140	alloy steel	450		

Rod diameters from 28 to 70 mm have rolled threads; in rolling process the component material is stressed beyond its yield point, being deformed plastically. This offers many technical advantages: higher profile accuracy, improved fatigue working life and high wear resistance. See **tab. B015** for the calculation of the expected rod fatigue life. The rod and piston are mechanically coupled by a threaded connection in which the thread on the rod is at least equal to the external thread KK, indicated in the tables [6], [10] and [15]. The piston is screwed to the rod by a prefixed tightening torque in order to improve the fatigue resistance. The stop pin ① avoids the piston unscrewing. **Contact our technical office** in case of heavy duty applications.

Rod corrosion resistance and hardness can be improved selecting the options **K** and **T** (option K affects the strength of standard rod, see **tab. B015** for the calculation of the expected rod fatigue life):

K = Nickel and chrome-plating (for rods from 28 to 110 mm)

Corrosion resistance (rating 10 to ISO 10289):

- 500 h in acetic acid salt spray to ISO 9227 AASS
- 1000 h in neutral spray to ISO 9227 NSS

T = Induction surface hardening and chrome plating:

- 56-60 HRC (613-697 HV) hardness

23 CUSHIONING

Cushioning are recommended for applications where: • the piston makes a full stroke with speed over than 0,05 m/s; • it is required to reduce undesirable noise and mechanical shocks; • vertical application with heavy loads. The stroke-end cushioning are hydraulic dampers specifically designed to dissipate the energy of the mass connected to the cylinder rod, by progressively increasing the pressure in the cushioning chamber and thus reducing the rod speed before the cylinder's mechanical stroke-end (see the graphics at side). See **tab. B015** for the max damping energy. The cylinder is provided with needle valve to optimize cushioning performances in different applications. The regulating screws are supplied fully screwed in (max cushioning effect).

In case of high masses and/or very high operating speeds we recommend to back them off to optimize the cushioning effect. The adjustment screw has a special design to prevent unlocking and expulsion. The cushioning effect is highly ensured even in case of variation of the fluid viscosity.

ø Bore	63	80	100	125	160	200
ø Rod	45	56	70	90	110	140
Cushioning length [mm]	Lf	27	29	27	25	34

24 POSITION OF THE OIL PORTS AND CUSHIONING ADJUSTMENTS

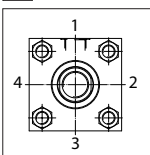

FRONT HEAD: **B1** = oil port position; **E*** = cushioning adjustment position

REAR HEAD: **X1** = oil port position.

The oil ports and cushioning adjustment positions are available, respectively, on sides 1 and 3 for all styles except E (see the figure at side): the style E has the cushioning adjustment on side 2.

Example of model code: CKM/00-50/22 *0500-S201 - D - **B1E3X1**

STROKE TOLERANCES

- 0 +2 mm for strokes up to 1250 mm
- 0 +5 mm for strokes from 1250 to 3150 mm
- 0 +8 mm for strokes over 3150 mm

RECOMMENDED SPACERS [mm]

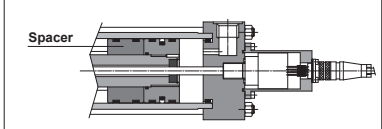

Stroke	1001 ÷ 1500	1501 ÷ 2000	2001 ÷ 2500	2501 ÷ 3000
Spacer code	2	4	6	8
Length	50	100	150	200

TIE RODS TIGHTENING TORQUES

ø Bore	40	50	63	80
MT [Nm]	20	70	70	160
Wrench	13	19	19	24
ø Bore	100	125	160	200
MT [Nm]	160	460	820	1160
Wrench	24	32	41	46

ROD-PISTON COUPLING

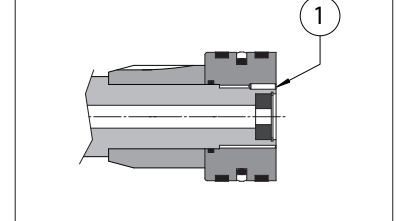

Lf is the total cushioning length. When the stroke-end cushioning are used as safety devices, to mechanically preserve the cylinder and the system, it is advisable to select the cylinder's stroke longer than the operating one by an amount equal to the cushioning length Lf; in this way the cushioning effect does not influence the movement during the operating stroke.

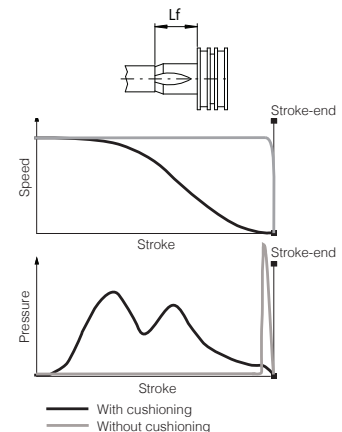

25 SEALING SYSTEM FEATURES

The sealing system must be chosen according to the working conditions of the system: speed, operating frequencies, fluid type and temperature. Additional verifications about minimum in/out rod speed ratio, static and dynamic sealing friction are warmly suggested, see **tab. B015**. Seals **2** and **4** not available for CKP since they are not compatible with glycol water and water based fluids.

Special sealing system for low temperature, high frequencies (up to 20 Hz), long working life and heavy duty are available, see **tab. TB020**. All the seals, static and dynamic, must be periodically replaced: proper spare kits are available, see **tab. B137**. Contact our technical office for the compatibility with other fluids not mentioned below and specify type and composition.

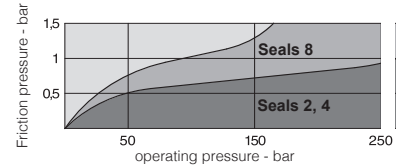

Sealing system	Material	Features	Max speed [m/s]	Fluid temperature range	Fluids compatibility	ISO Standards for seals	
						Piston	Rod
2	FKM + PTFE	very low friction and high temperatures	4	-20°C to 120°C	Mineral oils HH, HL, HLP, HLP-D, HM, HV, MIL-H-5606 fire resistance fluids HFA, HFB, HFC (water max 45%), HFD-U, HFD-R	ISO 7425/1	ISO 7425/2
4	NBR + PTFE	very low friction and high speeds	4	-20°C to 85°C	Mineral oils HH, HL, HLP, HLP-D, HM, HV, MIL-H-5606 fire resistance fluids HFA, HFC (water max 45%), HFD-U	ISO 7425/1	ISO 7425/2
8	NBR + PTFE + POLYURETHANE	low friction	0,5	-20°C to 85°C	Mineral oils HH, HL, HLP, HLP-D, HM, HV, MIL-H-5606	ISO 7425/1	ISO 7425/2

26 INCORPORATED SUBPLATE

CK* cylinders with oil ports positions 1 can be supplied with ISO (size 06, 10, 16 and 25) incorporated subplates for mounting of valves directly on the cylinder.

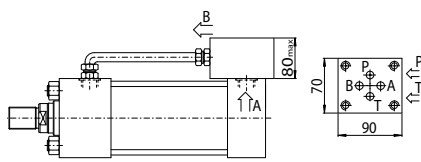

10 = subplate with mounting surface 4401-03-02-0-05 (size 06)
Oil ports P and T = G 3/8
For bores from 40 to 200 and strokes longer than 100 mm
For shorter strokes, the cylinder must be provided with suitable spacer

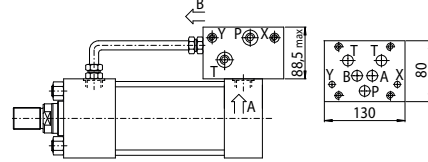

20 = subplate with mounting surface 4401-05-05-0-05 (size 10)
Oil ports P and T = G 3/4; X and Y = G 1/4
For bores from 40 to 200 and strokes longer than 150 mm
For shorter strokes, the cylinders must be provided with suitable spacer

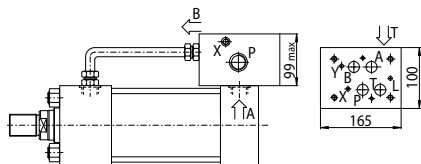

30 = subplate with mounting surface 4401-07-07-0-05 (size 16)
Oil ports P and T = G 1; L, X and Y = G 1/4
For bores from 80 to 200 and strokes longer than 150 mm
For shorter strokes, the cylinders must be provided with suitable spacer

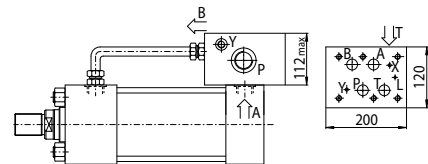

40 = subplate with mounting surface 4401-08-08-0-05 (size 25)
Oil ports P and T = G 1; L, X and Y = G 1/4
For bores from 125 to 200 and strokes longer than 150 mm
For shorter strokes, the cylinders must be provided with suitable spacer

Note: for the choice of suitable spacer see section 19. The addition of spacer length and working stroke must be at least equal or upper than the minimum stroke indicated above, see the following example:
Subplate **20**; working stroke = 70 mm; min. stroke = 150 mm → select spacer **4** (length = 100mm)

27 AIR BLEEDS

The air in the hydraulic circuit must be removed to avoid noise, vibrations and irregular cylinder's motion: air bleed valves realize this operation easily and safely. Air bleeds are positioned on side 3 except for rear heads of CKV, CKP cylinders with bores from 80 to 200 mm (on side 2) and for heads of mounting style **E** (on side 2), see section 24. For a proper use of the air-bleed (see figure on side) unlock the grub screw ① with a wrench for hexagonal head screws, moves the cylinder for the necessary cycles to bleed-off the air and retighten as indicated in table at side.

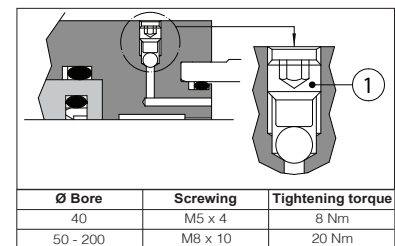

28 DRAINING

The rod side draining reduces the seals friction and increases their reliability. The draining is positioned on the same side of the oil port, between the wiper and the rod seals (see figure at side). It is recommended to connect the draining port to the tank without backpressure. Draining port is G1/8.

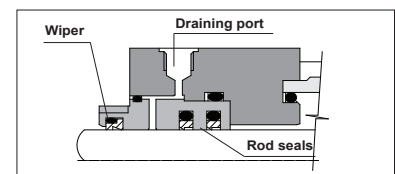

29 SIL compliance with IEC 61508: 2010

Servocylinders meets the requirements of:

- **SC3** (systematic capability)
- max **SIL 2** (HFT = 0 if the hydraulic system does not provide the redundancy for the specific safety function where the component is applied)
- max **SIL 3** (HFT = 1 if the hydraulic system provides the redundancy for the specific safety function where the component is applied)

30 SERVOCYLINDERS DERIVED FROM SERIES CH, CN, CC

Servocylinders derived from CH (ISO 6020-2 P = 160 bar; **tab. B140**), CH big bores (ISO 6020-3 P = 160 bar; **tab. B160**), CN (ISO 6020-1 P = 160 bar; **tab. B180**) and CC series (ISO 6022 P = 250 bar; **tab. B241**) are available on request. Contact our technical office for details.

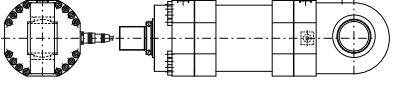
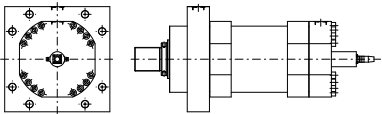
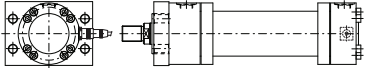
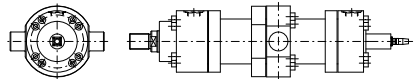
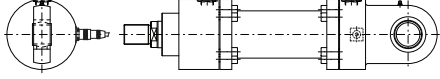
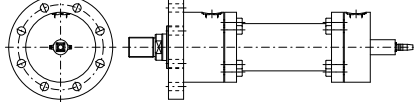
BASIC CYLINDER	DERIVED SERVOCYLINDERS	
<p>CH big bore (tab. B160) ISO 6020-3 Pnom 160 bar Pmax 250 bar Ø bore 250÷400 mm Ø rod 140÷220 mm</p>	<p>CHP, CHV - example of style "S"</p> 	<p>CHF, CHM - example of style "N"</p> 
<p>CN (tab. B180) ISO 6020-1 Pnom 160 bar Pmax 250 bar Ø bore 40÷200 mm Ø rod 22÷140 mm</p>	<p>CNP, CNV - example of style "N"</p> 	<p>CNF, CNM - example of style "L"</p> 
<p>CC (tab. B241) ISO 6022 Pnom 250 bar Pmax 320 bar Ø bore 50÷320 mm Ø rod 36÷220 mm</p>	<p>CCP, CCV - example of style "S"</p> 	<p>CCF, CCM - example of style "A"</p> 

31 SPARE PARTS - SEE TABLE SP-B310

Example for seals spare parts code

	G 8	-	CKF	-	125	/	90	
Sealing system								
Cylinder series								
Bore size [mm]								Rod diameter [mm]