













DISTRIBUTORI OLEODINAMICI DIRECTIONAL CONTROL VALVES

Codice fascicolo: 997-400-13410 Rev: AA

Data: Venerdì 16 maggio 2014

DISTRIBUTORI OLEODINAMICI DIRECTIONAL CONTROL VALVES

	GARATTERISTICHE GENERALI GENERAL FEATURES	pag. 3
	CONDIZIONI DI IMPIEGO CONDITIONS OF USE	pag. 4
	LT 30 1-2-3-4 LEVE/LEVERS	pag. 5
	LT 25 1-2-3 LEVE/LEVERS	pag. 7
	LT 25 4-5-6 LEVE/LEVERS	pag. 9
	LT 25 1-2-3-4-5-6 LEVE/LEVERS + COM. ELETT. + EM	pag. 11
	LT 60 1-2-3 LEVE/LEVERS	pag. 13
	LT 40 1-2-3-4-5-6-7-8 -9-10 LEVE/LEVERS	pag. 17
	LT 50 1-2-3-4-5 6-7-8-9 LEVE/LEVERS	pag. 19
	LT 120 1-2-3-4-5 6-7-8 LEVE/LEVERS	pag. 21
	CURSORI PILOT SHAFT	pag. 25
	TIPI AZIONAMENTO OPERATION TYPES	pag. 26

pag.1

CARATTERISTICHE GENERALI GENERAL FEATURES

134-001

Codice fascicolo: 997-400-13410 Rev: AA

Data: Venerdì 16 maggio 2014

DISTRIBUTORI MONOBLOCCO

Distributori per portate fino a 120 l/min e pressioni fino a 300 bar.

I corpi sono in ghisa ad alta resistenza. I cursori sono in acciaio al nichel cementati e temprati.

Ogni gruppo è normalmente corredato di valvola generale di massima pressione in entrata, e di valvola di non-ritorno.

L'alimentazione del distributore è standard a sinistra e, a richiesta, a destra.

La distribuzione è normalmente in parallelo, ma su alcuni modelli è disponibile anche in serie.

A richiesta sono disponibili valvole ausiliarie da flangiare sugli utilizzi (max. pressione, anti-urto, anti-cavitazione, di blocco pilotate e rigenerative) e valvole complementari.

Il comando cursore è normalmente manuale, a richiesta sono disponibili comandi pneumatici, elettro pneumatici, idraulici, elettro-idraulici, elettrici, con cavi flessibili.

DISTRIBUTORI COMPONIBILI

Distributori ad elementi componibili per portate fino a 220 l/min e pressioni fino a 300 bar.

Gli elementi e le fiancate sono in ghisa ad alta resistenza. I cursori sono in acciaio al carbonio nichelati.

Ogni gruppo è corredato di valvola generale di massima pressione in entrata.

Ogni elemento è dotato di valvola di non ritorno ed è predisposto per il montaggio di valvole ausiliarie (anti-urto, max.pressione e anti-cavitazione). È possibile inoltre montare valvole di blocco pilotate flangiate sugli utilizzi.

L'alimentazione del distributore è standard a sinistra e, a richiesta, a destra. La distribuzione può essere in parallelo, serie e serie-parallelo.

Il comando cursore è normalmente manuale, a richiesta sono disponibili comandi pneumatici, idraulici, elettrici, elettroidraulici, con cavi flessibili.

Sono disponibili elementi intermedi speciali con valvola di max.pressione, valvola prioritaria, valvola di esclusione, divisori di portata con regolatore, collettori di scarico.

Il nostro Servizio Tecnico Commerciale è a completa disposizione per qualsiasi ulteriore chiarimento circa le applicazioni di questo prodotto.

SINGLE DIRECTIONAL CONTROL VALVES

Directional control valves for flows up to 120 l/min and pressures up to 300 bar.

The valve bodies are in high strength cast iron. The pilot shafts are in casehardened and tempered nickel steel.

Each unit is generally supplied with a maximum pressure valve at the inlet and a non-return valve.

The directional control valve is supplied with a left hand feed as standard; right hand feed can be supplied on request.

Distribution is generally in parallel, though series distribution is available on some models.

Auxiliary valves for flange fitting to the service ports (max. pressure, shockproof, anti-cavitation, piloted block valves and recovery valves) and supplementary valves are available on request.

Pilot shaft control is normally manual, though pneumatic, electro-pneumatic, hydraulic, electro-hydraulic and electric controlled levers with flexible cables are available on request.

MULTIPLE DIRECTIONAL CONTROL VALVES

Multiple directional control valves for flows up to 220 l/min and pressures up to 300 bar.

Bodies and side elements are in high strength cast iron. Control levers are in nickel plated carbon steel.

Each group is equipped with a main max. inlet pressure valve.

Each single unit is fitted with a non-return valve and is designed to accept auxiliary valves (shockproof, max. pressure and anti-cavitation). Piloted block valves with flange fitting to the service ports can also be mounted.

The directional control valve is supplied with a left hand feed as standard; right hand feed can be supplied on request.

Distribution can be parallel, series or series-parallel.

Pilot shaft control is normally manual, though pneumatic, hydraulic, electric and electro-hydraulic controlled levers with flexible cables are available on request.

Special intermediate elements are also available: max. pressure valve, priority valve, stop valves, flow distribution valves with regulator, tank outlet manifolds.

Our Technical Sales Department is available for any further clarification regarding the applications of this product.

pag.3

Temperatura ambientale : da -40 a + 100 °C <i>Ambient temperature : from -40 to +100C</i>	Viscosità cinematica : da 10 a 500 mm ² /s <i>Kinematic viscosity : from 10 to 500 mm²/s</i>	
Fluido idraulico : consultare tabella <i>Hydraulic fluid : see table</i>	Contaminazione ammessa : 29/18 (ISO/DIS 4406) <i>Allowed contamination : 29/18 (ISO/DIS 4406)</i>	
FLUIDO - FLUID	GUARNIZIONI - GASKETS	
* NBR Elastomero in gomma nitrilica resistente ad oli minerali e grassi. ** FPM Elastomero fluorurato (VITON) resistente al calore ed agli altri agenti chimici. * <i>NBR Elastomer in mineral oil-resistant and grease-resistant nitrile rubber and mineral oli and grease.</i> ** <i>FPM Fluorinated heat-resistant and chemical resistant elastomer (VITON).</i>	NBR*	FPM**
		CAMPO DI TEMPERATURA DEL FLUIDO (°C) FLUID TEMPERATURE RANGE (°C)
Olio minerale HLP secondo DIN 51524 e 51525 <i>HLP mineral oil according to DIN 51524 and 51525</i>	●	●
Acqua con olio (emulsione con max. 20% di componenti infiammabili) <i>Water with oil (emulsion with max. 20% flammable components)</i>	●	
Olio con acqua (emulsione con max. 60% di componenti infiammabili) <i>Oil with water (emulsion with max. 60% flammable components)</i>	●	
Soluzioni acquose a base di poliglicoli (40%-60% di acqua) <i>Polyglycol based aqueous solution (40%-60% water)</i>	●	
Etere dell'acido fosforico - <i>Phosphoric acid ether</i>		●
Idrocarburi clorurati (Benzene, Clorobenzene) <i>Chlorinated hydrocarbons</i>		●
Miscele di etere e idrocarburi - <i>Mixture of ether and hydrocarbons</i>		●

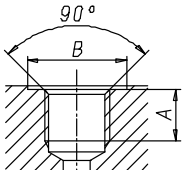
	Dimensioni Dimensions	BSP							
		G 1/8	G 1/4	G 3/8	G 1/2	G 3/4	G 1	G 1 1/4	G 1 1/2
	A	10	14	14	16	18	20	22	24
B (min.)	15	19	23	27	33	40	50	56	

DISTRIBUTORI MONOBLOCCO "LT 30" A 1-2-3-4 LEVE

CODICE FAMIGLIA
FAMILY CODE

134-001





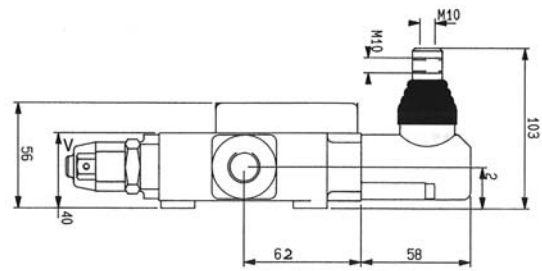
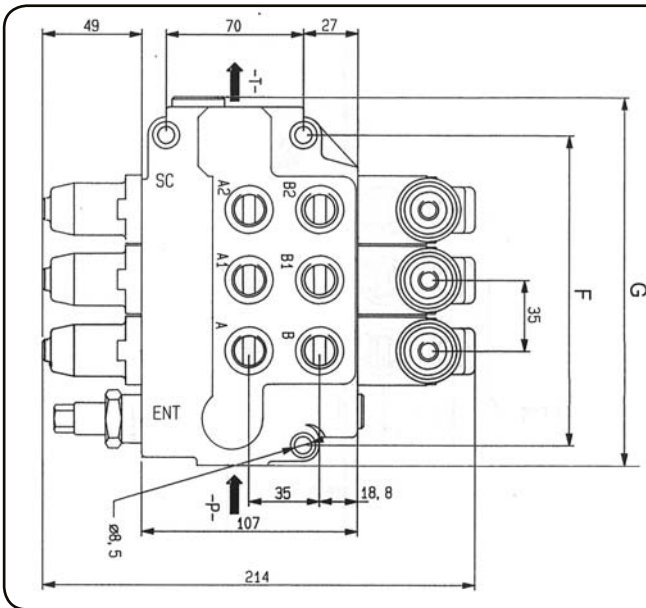
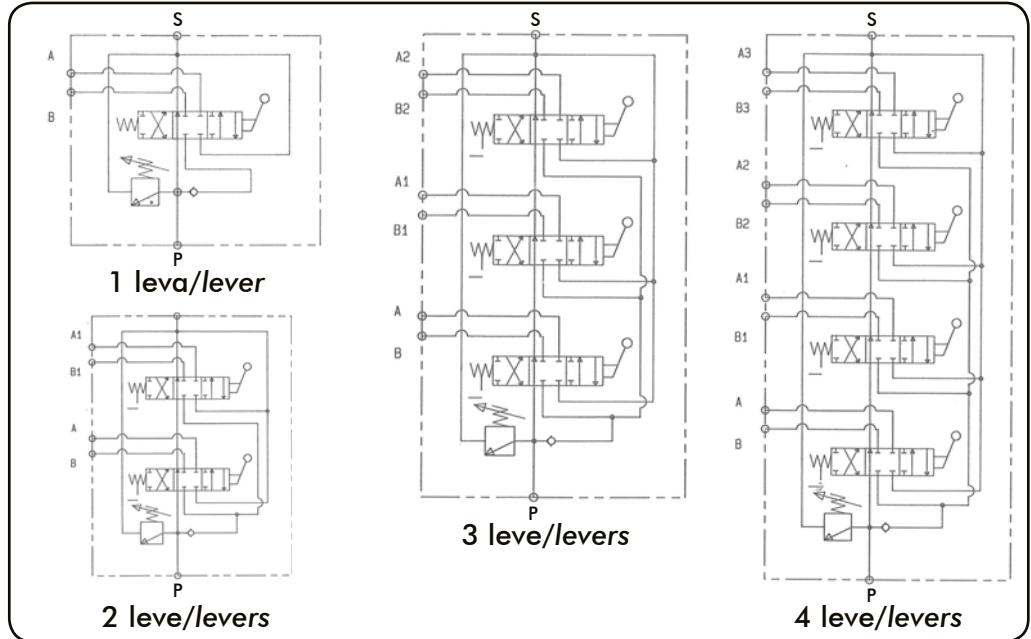

DIRECTIONAL CONTROL VALVES "LT30" WITH 1-2-3-4 LEVERS

LT 30

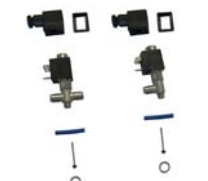

Simbolo / Symbol	Descrizione / Description
P	Pressione - Pressure
A-B	Utilizzi - Service ports
(S) T	Scarico - Tank outlet
V	Regolazione press. max. - Relief valve adijustamet
R	Tappo valvola controllo scarico Load control valve plug
+ MCR	Con microinterruttore - With microswitch

Tipo Type	Codice Code	Portata Flow l/min	Pressione Pressure bar	Dimensioni Dimension mm		Filettature disponibili Available thread		Peso Weight Kg
				F	G	P-A-B	(S) T	
1 Leva - lever	134-001-00103	30	250	84	113	3/8" BSP	1/2" BSP	3,4
1 Leva+MCR - lever	134-001-00176							3,6
2 Leve - levers	134-001-00194			4,8				
2 Leve+MCR - levers	134-001-00201			5,0				
3 Leve - levers	134-001-00229			6,4				
3 Leve+MCR - levers	134-001-00238			6,6				
4 Leve - levers	134-001-00256			7,8				
4 Leve+MCR - levers	134-001-00265			8,0				

	CODICE/ CODE	DESCRIZIONE/DESCRIPTION
	134-002-00095	Kit servocomando pneumatico LT 25/30 <i>Pneumatic servo control kit LT 25/30</i>
	134-016-00491 134-016-00508	Kit ev. + raccordi per servocomando elettropneumatico 12V e 24V <i>Electropneumatic servo control kit 12V-24V</i>
	134-002-00353	Kit movimento scatto/scatto LT 25/30 <i>Lock/lock kit LT 25/30</i>
	134-002-00362	Kit movimento scatto/molla LT 25/30 <i>Lock/spring kit LT 25/30</i>
	134-002-00157	Tappo "H" doppio scarico <i>"H" double outlet plug</i>
	134-002-00344	Tappo "D" centro chiuso <i>"D" center closed plug</i>
	134-002-00139	Gruppo leva completo <i>Assembly lever group</i>
	134-002-00166	Leva nuda + pomello <i>Lever + knob</i>

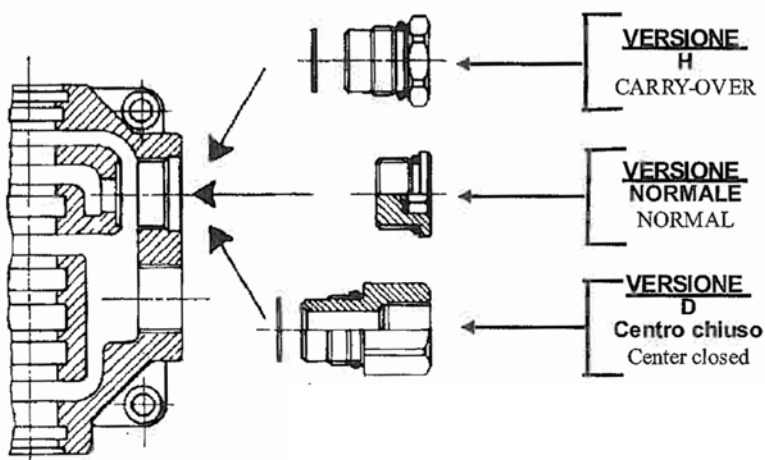

Codice / Code	Descrizione / Description	Versione Version
134-002-00157	Tappo "Doppio scarico" LT 30 <i>Double outlet plug for LT 30</i>	H
134-002-00344	Tappo "Centro chiuso" LT 30 <i>Center closed plug for LT 30</i>	D

DISTRIBUTORI MONOBLOCCO "LT 25" A 1-2-3 LEVE

CODICE FAMIGLIA
FAMILY CODE

134-003

DIRECTIONAL CONTROL VALVES "LT25" WITH 1-2-3 LEVERS

LT 25

Codice fascicolo: 997-400-13410 Rev: AA

Data: Venerdì 16 maggio 2014

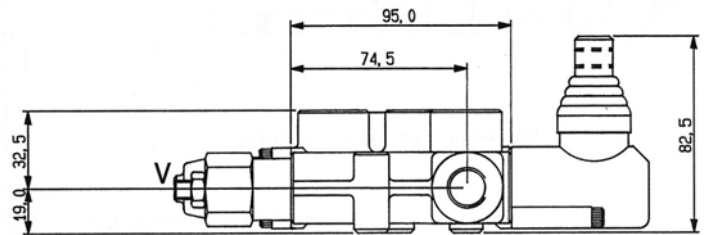
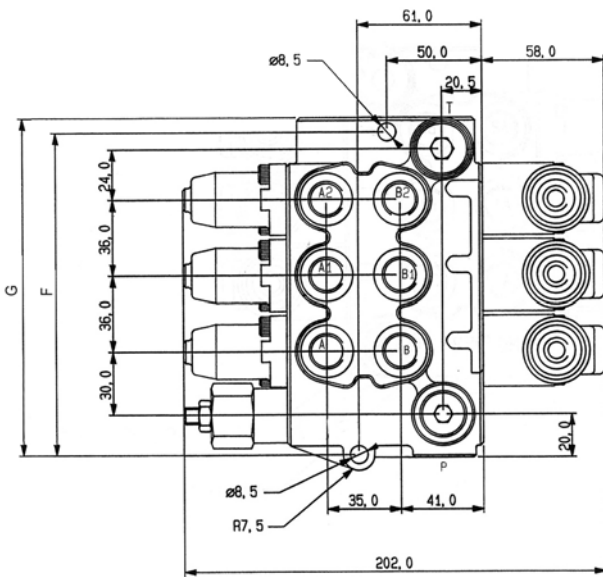
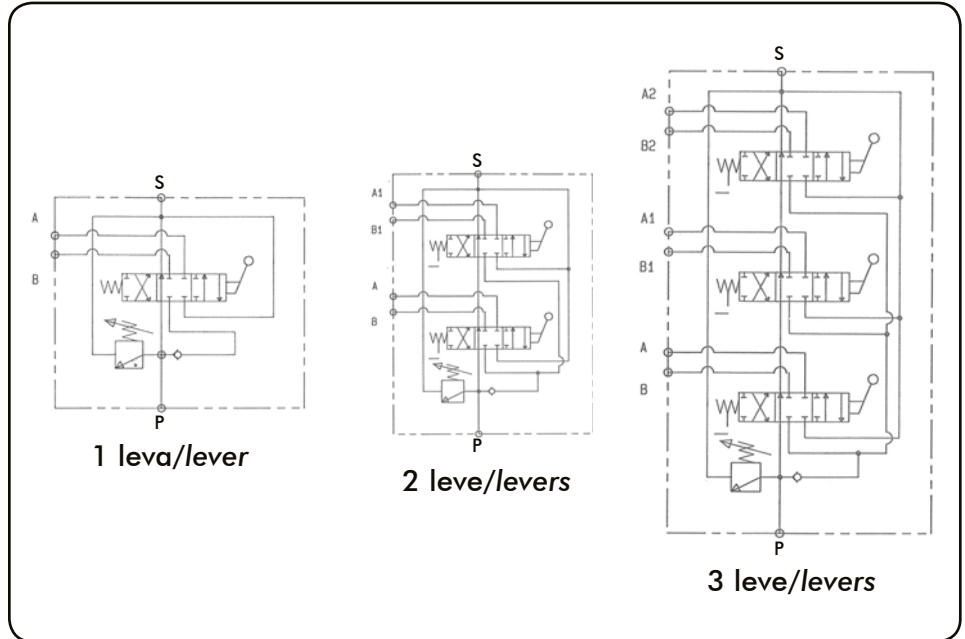

Simbolo / Symbol	Descrizione / Description
P	Pressione - Pressure
A-B	Utilizzi - Service ports
(S) T	Scarico - Tank outlet
V	Regolazione press. max. - Relief valve adjustament
R	Tappo valvola controllo scarico Load control valve plug
+ MCR	Con microinterruttore - With microswitch







Tipo Type	Codice Code	Portata Flow l/min	Pressione Pressure bar	Dimensioni Dimension mm		Filettature disponibili Available thread		Peso Weight Kg
				F	G	P-A-B	T	
1 Leva - lever	134-003-00012	25	250	81	88	3/8" BSP	1/2" BSP	1,1
1 Leva+MCR - lever	134-003-10010							1,3
2 Leve - levers	134-003-00021			3,2				
2 Leve+MCR - levers	134-003-10029			3,4				
3 Leve - levers	134-003-00030			4,8				
3 Leve+MCR - levers	134-003-10038			5				

pag.7

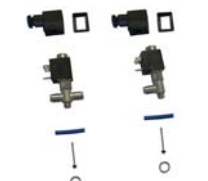
OMFB
HYDRAULIC COMPONENTS

O.M.F.B. S.p.A. Hydraulic Components
We reserve the right to make any changes without notice.
Edition 2011.09 No reproduction, however partial, is permitted.
Via Cave, 7/9 25050 Provaglio d'Iseo (Brescia) Italy Tel.: +39.030.9830611
Fax: +39.030.983207-208 Internet: www.omfb.it e-mail: info@omfb.it

COMPANY WITH
QUALITY SYSTEM
CERTIFIED BY DNV GL
= ISO 9001 =

	CODICE/ CODE	DESCRIZIONE/DESCRIPTION
	134-002-00095	Kit servocomando pneumatico LT 25/30 <i>Pneumatic servo control kit LT 25/30</i>
	134-016-00491 134-016-00508	Kit ev. + raccordi per servocomando elettropneumatico 12V e 24V <i>Electropneumatic servo control kit 12V-24V</i>
	134-002-00353	Kit movimento scatto/scatto LT 25/30 <i>Lock/lock kit LT 25/30</i>
	134-002-00362	Kit movimento scatto/molla LT 25/30 <i>Lock/spring kit LT 25/30</i>
	134-004-00011	Tappo "H" doppio scarico <i>"H" double outlet plug</i>
	134-004-00066	Tappo "D" centro chiuso <i>"D" center closed plug</i>
	134-004-00075	Gruppo leva completo <i>Assembly lever group</i>
	134-004-00164	Leva nuda + pomello <i>Lever + knob</i>

ALTRI ACCESSORI / OTHERS ACCESSORIES

- 134-004-00137 Valvola di massima pressione / *Relief valve*

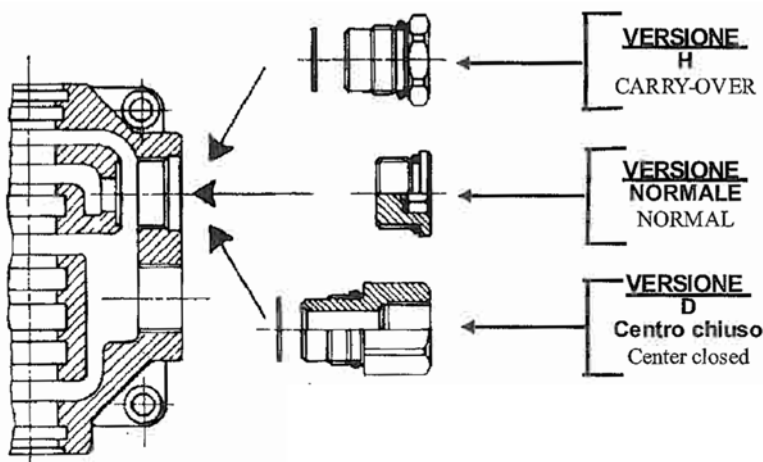

Code / Code	Descrizione / Description	Versione / Version
134-004-00011	Tappo "Doppio scarico" LT 25 <i>Double outlet plug for LT 25</i>	H
134-004-00066	Tappo "Centro chiuso" LT 25 <i>Center closed plug for LT 25</i>	D

DISTRIBUTORI MONOBLOCCO "LT 25" A 4-5-6 LEVE

CODICE FAMIGLIA
FAMILY CODE

134-003

DIRECTIONAL CONTROL VALVES "LT25" WITH 4-5-6 LEVERS

LT 25

Codice fascicolo: 997-400-13410 Rev: AA

Data: Venerdì 16 maggio 2014

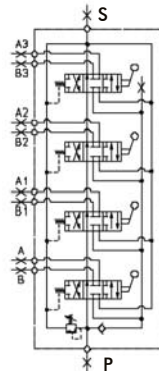

4 leve/levers

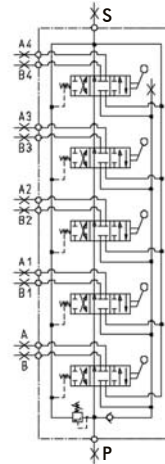

5 leve/levers

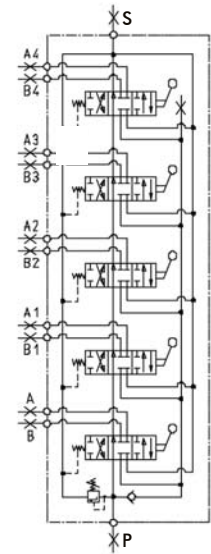



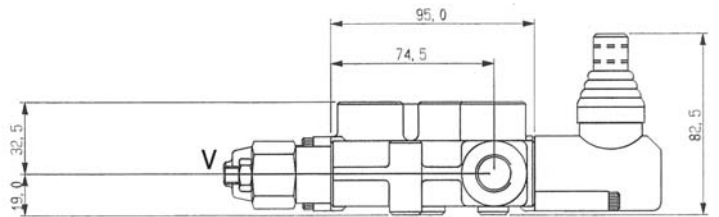
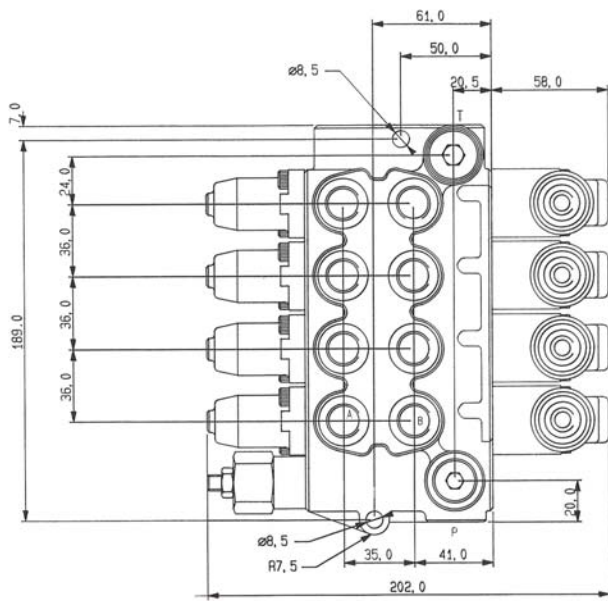





6 leve/levers



Simbolo / Symbol	Descrizione / Description
P	Pressione - Pressure
A-B	Utilizzi - Service ports
(S) T	Scarico - Tank outlet
V	Regolazione press. max. - Relief valve adjustamnt
R	Tappo valvola controllo scarico Load control valve plug
+ MCR	Con microinterruttore - With microswitch

Tipo Type	Codice Code	Portata Flow l/min	Pressione Pressure bar	Dimensioni Dimension mm		Filettature disponibili Available thread		Peso Weight Kg
				F	G	P-A-B	T	
4 Leve - levers	134-003-00049	25	250	189	196	3/8" BSP	1/2" BSP	6
4 Leve+MCR - lever	134-003-10047			6,2				
5 Leve - levers	134-003-00058			6,9				
5 Leve+MCR - levers	134-003-10056			7,1				
6 Leve - levers	134-003-00067			8				
6 Leve+MCR - levers	134-003-10065			8,2				

	CODICE/ CODE	DESCRIZIONE/DESCRIPTION
	134-002-00095	Kit servocomando pneumatico LT 25/30 <i>Pneumatic servo control kit LT 25/30</i>
	134-016-00491 134-016-00508	Kit ev. + raccordi per servocomando elettropneumatico 12V e 24V <i>Electropneumatic servo control kit 12V-24V</i>
	134-002-00353	Kit movimento scatto/scatto LT 25/30 <i>Lock/lock kit LT 25/30</i>
	134-002-00362	Kit movimento scatto/molla LT 25/30 <i>Lock/spring kit LT 25/30</i>
	134-004-00011	Tappo "H" doppio scarico <i>"H" double outlet plug</i>
	134-004-00066	Tappo "D" centro chiuso <i>"D" center closed plug</i>
	134-004-00075	Gruppo leva completo <i>Assembly lever group</i>
	134-004-00164	Leva nuda + pomello <i>Lever + knob</i>

ALTRI ACCESSORI / OTHERS ACCESSORIES

- 134-004-00137 Valvola di massima pressione / Relief valve

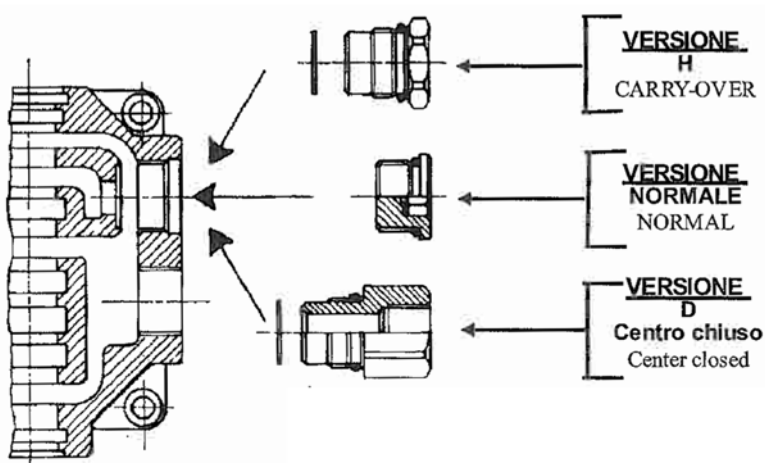

Codice / Code	Descrizione / Description	Versione Version
134-004-00011	Tappo "Doppio scarico" LT 25 <i>Double outlet plug for LT 25</i>	H
134-004-00066	Tappo "Centro chiuso" LT 25 <i>Center closed plug for LT 25</i>	D

DISTRIBUTORI MONOBLOCCO "LT 25" A 1-2-3-4-5-6 LEVE

CODICE FAMIGLIA
FAMILY CODE

134-003

DIRECTIONAL CONTROL VALVES "LT25" WITH 1-2-3-4-5-6 LEVERS

LT 25



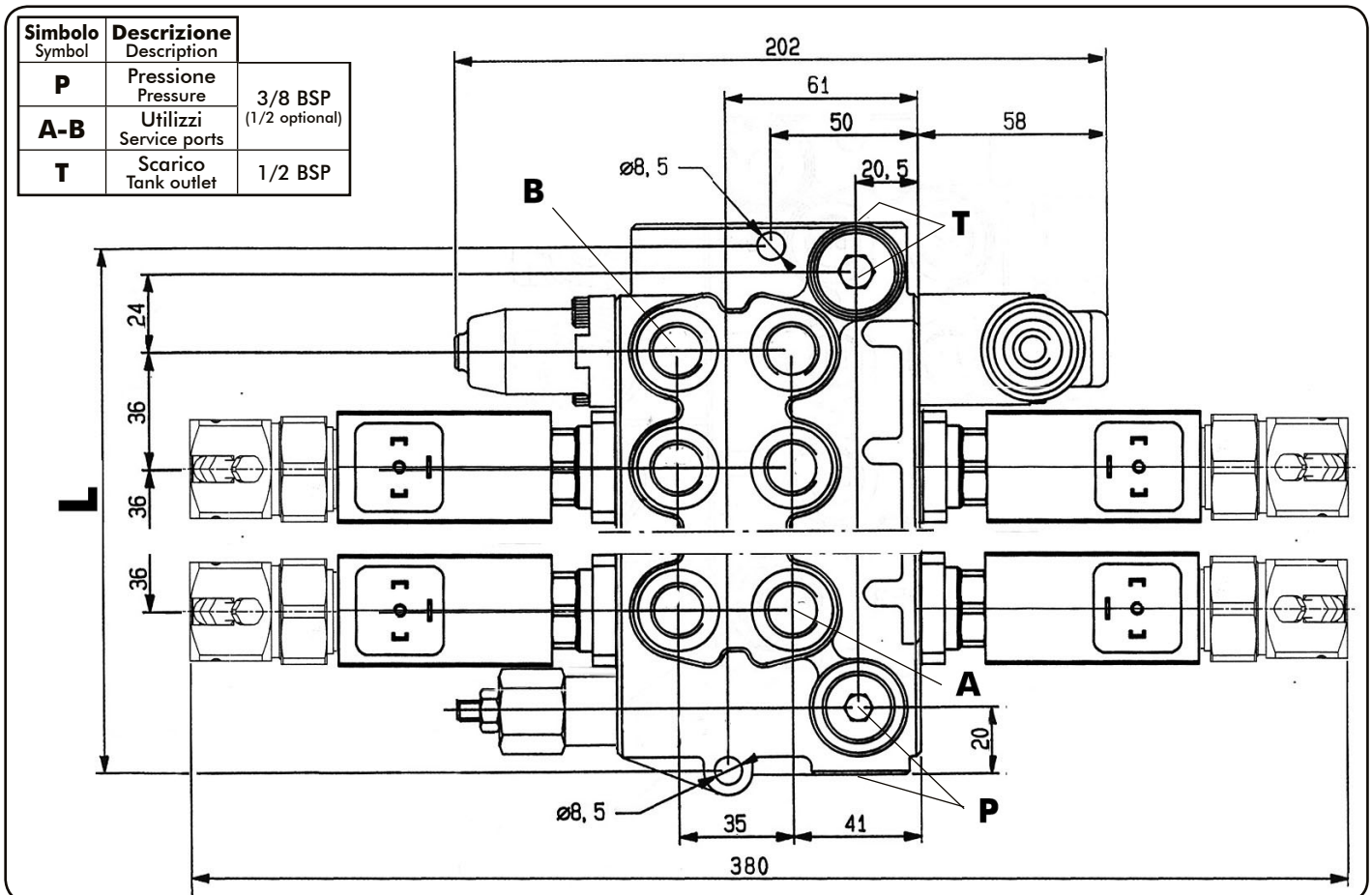
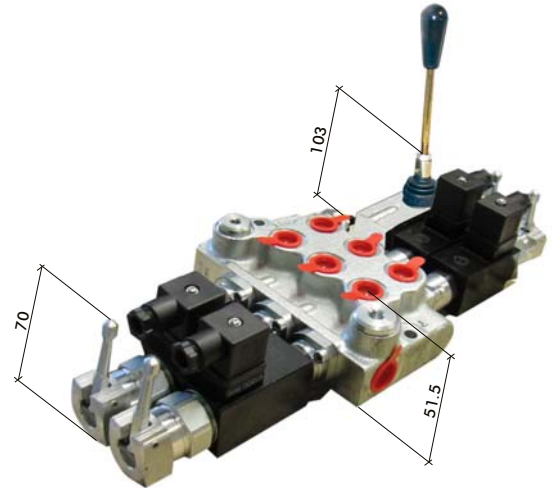
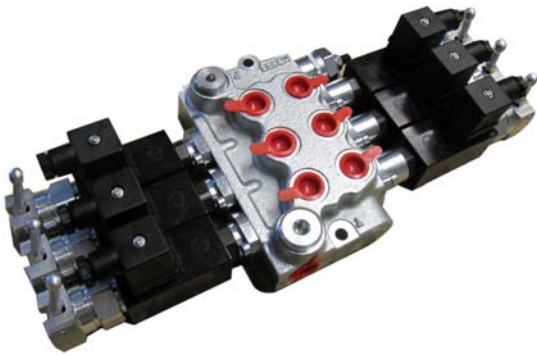

**CON COMANDO ELETTRICO ED EMERGENZA MANUALE
WITH ELECTRIC CONTROL AND MANUAL EMERGENCY**



Traduzione: 1 leva + 1 comando elettrico 12V + emergenza manuale
 Translation: 1 lever + 1 electric control 12V + manual emergency

Typo / Type	Codice / Code	Portata Flow l/min	Pressione Pressure bar	L mm	Peso Weight Kg
1 leva + 1 comando elettrico 12V + emergenza manuale	134-003-11126	25	250	81	3.6 Kg
1 leva + 1 comando elettrico 24V + emergenza manuale	134-003-11242				4.8 Kg
2 leve + 1 comando elettrico 12V + emergenza manuale	134-003-21124			117	6.1 Kg
2 leve + 1 comando elettrico 24V + emergenza manuale	134-003-21240				5.9 Kg
2 leve + 2 comandi elettrici 12V + emergenza manuale	134-003-22123			153	7.2 Kg
2 leve + 2 comandi elettrici 24V + emergenza manuale	134-003-22249				8.5 Kg
3 leve + 1 comando elettrico 12V + emergenza manuale	134-003-31122			189	7.1 Kg
3 leve + 1 comando elettrico 24V + emergenza manuale	134-003-31248				8.5 Kg
3 leve + 2 comandi elettrici 12V + emergenza manuale	134-003-32121			225	10 Kg
3 leve + 2 comandi elettrici 24V + emergenza manuale	134-003-32247				11.2 Kg
3 leve + 3 comandi elettrici 12V + emergenza manuale	134-003-33120			261	8.3 Kg
3 leve + 3 comandi elettrici 24V + emergenza manuale	134-003-33246				9.6 Kg
4 leve + 1 comando elettrico 12V + emergenza manuale	134-003-41120			225	10.8 Kg
4 leve + 1 comando elettrico 24V + emergenza manuale	134-003-41246				12 Kg
4 leve + 2 comandi elettrici 12V + emergenza manuale	134-003-42129			261	13.5 Kg
4 leve + 2 comandi elettrici 24V + emergenza manuale	134-003-42245				9.5 Kg
4 leve + 3 comandi elettrici 12V + emergenza manuale	134-003-43128			10.8 Kg	12.1 Kg
4 leve + 3 comandi elettrici 24V + emergenza manuale	134-003-43244				13.5 Kg
4 leve + 4 comandi elettrici 12V + emergenza manuale	134-003-44127			14.3 Kg	16 Kg
4 leve + 4 comandi elettrici 24V + emergenza manuale	134-003-44243				9.5 Kg
5 leve + 1 comando elettrico 12V + emergenza manuale	134-003-51128			225	10.8 Kg
5 leve + 1 comando elettrico 24V + emergenza manuale	134-003-51244				12.1 Kg
5 leve + 2 comandi elettrici 12V + emergenza manuale	134-003-52127			261	13.5 Kg
5 leve + 2 comandi elettrici 24V + emergenza manuale	134-003-52243				14.3 Kg
5 leve + 3 comandi elettrici 12V + emergenza manuale	134-003-53126			10.8 Kg	12.1 Kg
5 leve + 3 comandi elettrici 24V + emergenza manuale	134-003-53242				13.5 Kg
5 leve + 4 comandi elettrici 12V + emergenza manuale	134-003-54125			14.3 Kg	16 Kg
5 leve + 4 comandi elettrici 24V + emergenza manuale	134-003-54241				9.5 Kg
5 leve + 5 comandi elettrici 12V + emergenza manuale	134-003-55124			10.8 Kg	12.1 Kg
5 leve + 5 comandi elettrici 24V + emergenza manuale	134-003-55240				13.5 Kg
6 leve + 1 comando elettrico 12V + emergenza manuale	134-003-61126			225	10.8 Kg
6 leve + 1 comando elettrico 24V + emergenza manuale	134-003-61242				12.1 Kg
6 leve + 2 comandi elettrici 12V + emergenza manuale	134-003-62125			261	13.5 Kg
6 leve + 2 comandi elettrici 24V + emergenza manuale	134-003-62241				14.3 Kg
6 leve + 3 comandi elettrici 12V + emergenza manuale	134-003-63124			10.8 Kg	12.1 Kg
6 leve + 3 comandi elettrici 24V + emergenza manuale	134-003-63240				13.5 Kg
6 leve + 4 comandi elettrici 12V + emergenza manuale	134-003-64123			14.3 Kg	16 Kg
6 leve + 4 comandi elettrici 24V + emergenza manuale	134-003-64249				9.5 Kg
6 leve + 5 comandi elettrici 12V + emergenza manuale	134-003-65122			10.8 Kg	12.1 Kg
6 leve + 5 comandi elettrici 24V + emergenza manuale	134-003-65248				13.5 Kg
6 leve + 6 comandi elettrici 12V + emergenza manuale	134-003-66121			14.3 Kg	16 Kg
6 leve + 6 comandi elettrici 24V + emergenza manuale	134-003-66247				9.5 Kg

ACCESSORI / ACCESSORIES

	134-004-00100	Dispositivo emergenza a leva per 1 solenoide serv. elt. dir. Lever emergency
	134-004-00146	Tubo + flangia per AED lato v.max. Tube + flange v.max side
	134-004-00155	Tubo + flangia per AED lato leva Tube + flange lever side
	134-004-00226 134-004-00235	Bobina 12/24V qdr. per servocomando diretto Coil

DISTRIBUTORI MONOBLOCCO "LT 60" A 1-2-3 LEVE

CODICE FAMIGLIA
FAMILY CODE

134-015

DIRECTIONAL CONTROL VALVES "LT60" WITH 1-2-3 LEVERS

LT 60

Codice fascicolo: 997-400-13410 Rev: AA

Data: Venerdì 16 maggio 2014

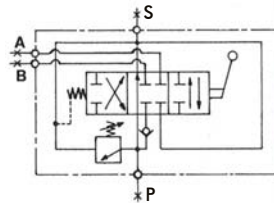

1 leva/lever

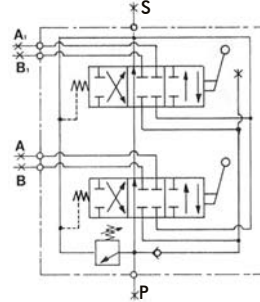

2 leve/levers

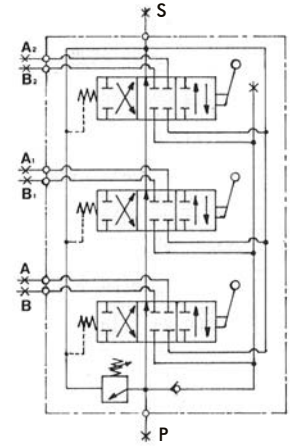

3 leve/levers

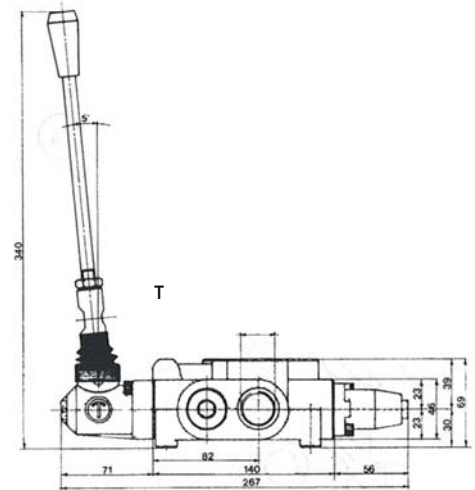
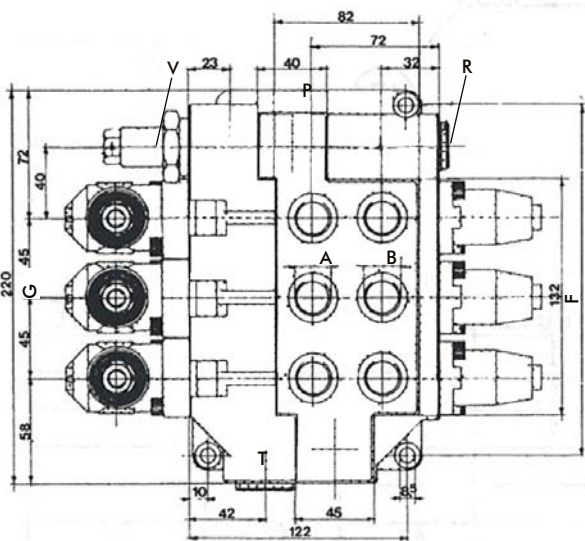

Simbolo / Symbol	Descrizione / Description
P	Pressione - Pressure
A-B	Utilizzi - Service ports
(S) T	Scarico - Tank outlet
V	Regolazione press. max. - Relief valve adjustmet
R	Tappo valvola controllo scarico Load control valve plug

Tipo Type	Codice Code	Portata Flow l/min	Pressione Pressure bar	Dimensioni Dimension mm		Filettature disponibili Available thread		Peso Weight Kg
				F	G	P-A-B	T	
1 Leva - lever	134-015-00027	60	250	106	130	1/2" BSP	3/4" BSP	6,4
2 Leve - levers	134-015-00045			151	175			9,3
3 Leve - levers	134-015-00063			196	220			12,2

pag.13



O.M.F.B. S.p.A. Hydraulic Components
We reserve the right to make any changes without notice.
Edition 2011.09 No reproduction, however partial, is permitted.
Via Cave, 7/9 25050 Provaglio d'Iseo (Brescia) Italy Tel.: +39.030.9830611
Fax: +39.030.983207-208 Internet: www.omfb.it e-mail: info@omfb.it

COMPANY WITH
QUALITY SYSTEM
CERTIFIED BY DNV GL
= ISO 9001 =

	CODICE/ CODE	DESCRIZIONE/DESCRIPTION
	134-016-00035	Kit servocomando pneumatico LT 60/120 <i>Pneumatic servo control kit LT 60/120</i>
	134-016-00491 134-016-00508	Kit elettrovalvole + raccordi per servocomando elettropneumatico 12V e 24V <i>Electropneumatic servo control kit 12V-24V</i>
	134-016-00099 134-016-00106	Bobina 12V o 24V per servocomando. <i>Coil</i>
	134-016-00197	Kit servocomando eletroidraulico 24V <i>Electrohydraulic 24V kit</i>
	134-016-00204	Valvola contropressione scarico per servocomando eletroidraulico. <i>Back-pressure valves</i>
	134-016-00017	Kit movimento scatto/scatto LT 60/120 <i>Lock/lock kit LT 60/120</i>
	134-016-00179	Kit movimento scatto/molla LT 60/120 <i>Lock/spring kit LT 60/120</i>
	134-016-00062	Tappo "H" doppio scarico <i>"H" double outlet plug</i>
	134-016-00213	Tappo "D" centro chiuso <i>"D" center closed plug</i>
	134-016-00151	Gruppo leva completo <i>Assembly lever group</i>
	134-016-00446	Leva nuda + pomello <i>Lever + knob</i>

ALTRI ACCESSORI / OTHERS ACCESSORIES

- **134-016-00375** Valvola contropressione entrata per serv. elet. / *Back-pressure valves*
- **134-016-00384** Valvola di massima pressione / *Relief valve*
- **134-016-00393** Kit movimento 2 posizioni molla / *2 positions spring kit*

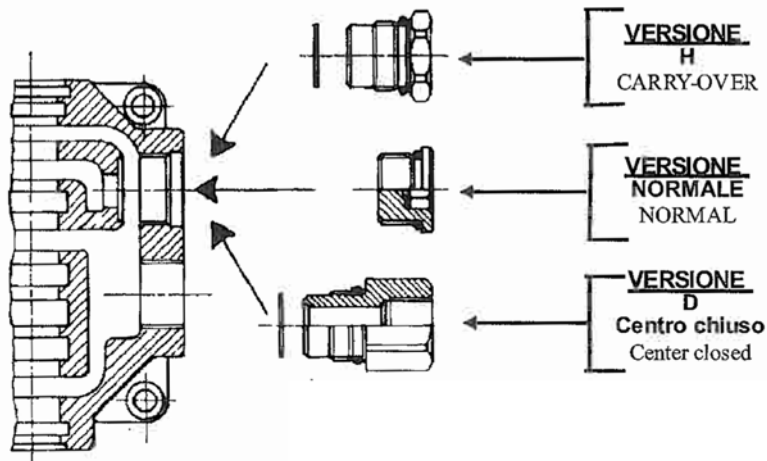

Codice / Code	Descrizione / Description	Versione / Version
134-016-00062	Tappo "Doppio scarico" LT 60 <i>Double outlet plug for LT 60</i>	H
134-016-00213	Tappo "Centro chiuso" LT 60 <i>Center closed plug for LT 60</i>	D

DISTRIBUTORI COMPOSTO "LT 40" A 1-2-3-4-5-6-7-8-9-10 LEVE DIRECTIONAL CONTROL VALVES "LT40" WITH 1-2-3-4-5-6-7-8-9-10 LEVERS

CODICE FAMIGLIA
FAMILY CODE

134-021

LT 40

Codice fascicolo: 997-400-13410 Rev: AA

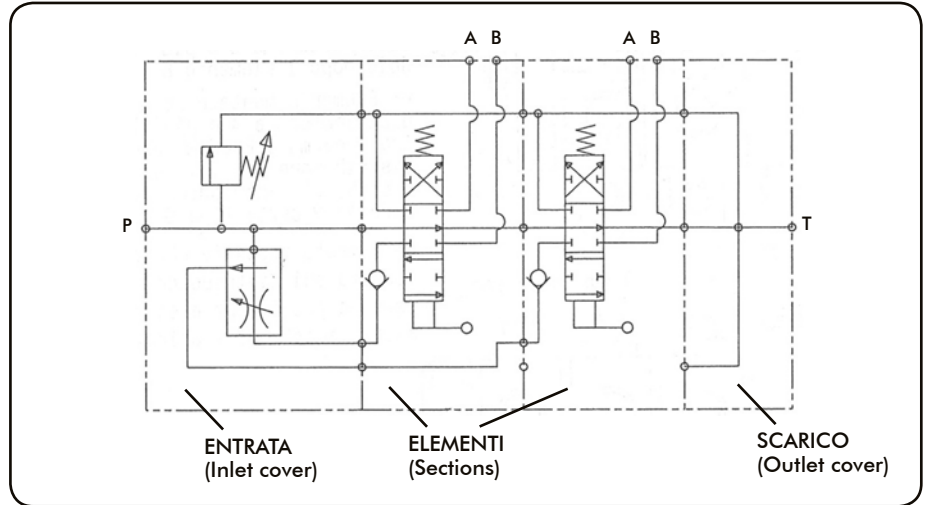



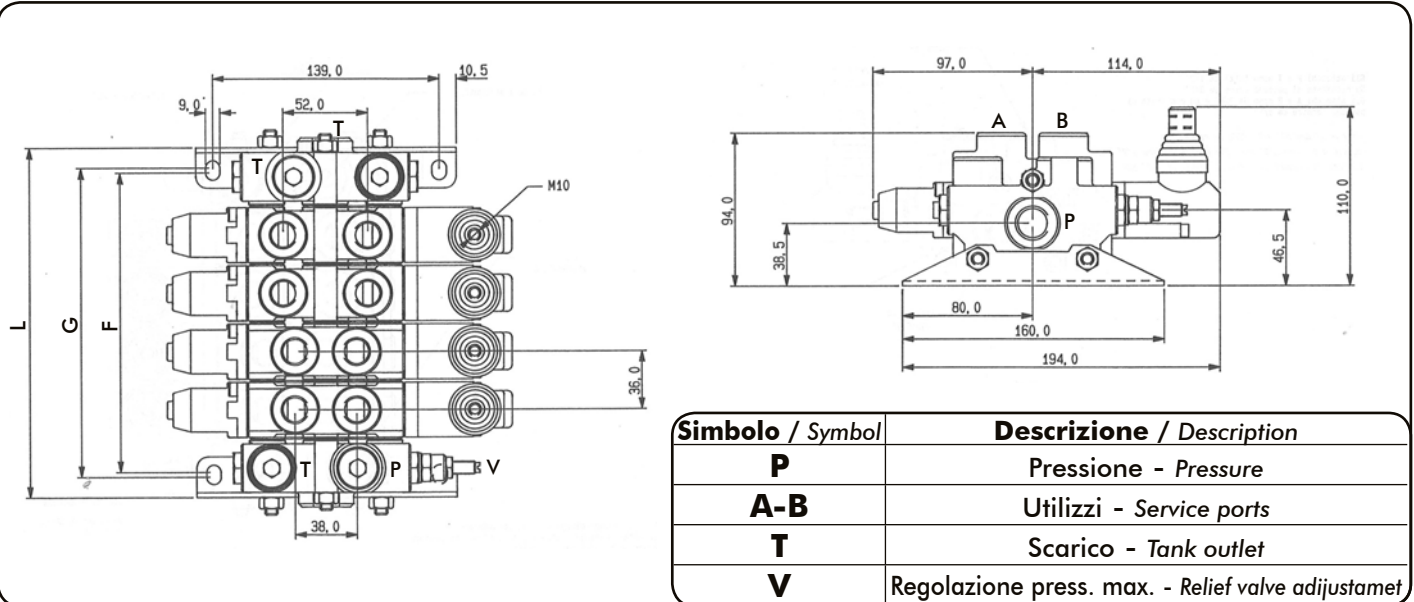

Data: Venerdì 16 maggio 2014

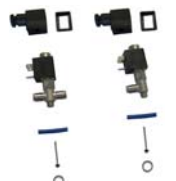

Tipo Type	Codice Code	Portata Flow l/min	Pressione Pressure bar	Dimensioni Dimension mm			Filettature disponibili Available thread				Peso Weight Kg
				F	G	L	P	A	B	T	
1 Leva - lever	134-021-00010	40	280	77	83	108	1/2" BSP	3/8" BSP	3/8" BSP	1/2" BSP	4,5
2 Leve - levers	134-021-00029			113	119	144					6
3 Leve - levers	134-021-00038			149	155	180					7,5
4 Leve - levers	134-021-00047			185	191	216					9
5 Leve - levers	134-021-00056			221	227	252					10,5
6 Leve - levers	134-021-00065			257	263	288					12
7 Leve - levers	134-021-00074			293	299	324					13,5
8 Leve - levers	134-021-00083			329	335	360					15
9 Leve - levers	134-021-00092			365	371	396					16,5
10 Leve - levers	134-001-00109			401	407	432					18

Gli attacchi P e T sono tutti da 1/2" su richiesta si possono avere da 3/8". Connections P and T are all 1/2" BSP 3/8" BSP is available on request.
Gli attacchi A e B sono tutti da 3/8" su richiesta si possono avere da 1/2". Connections A and B are 3/8" BSP 1/2" BSP is available on request.

	CODICE/ CODE	DESCRIZIONE/DESCRIPTION
	134-020-00388	Kit servocomando pneumatico LT40/08-50 <i>Pneumatic servo control kit LT40/08-50</i>
	134-016-00491 134-016-00508	Kit elettrovalvole + raccordi per servocomando elettropneumatico 12V e 24V <i>Electropneumatic servo control kit 12V-24V</i>
	134-022-00108	Kit movimento scatto/scatto LT 40-08/50 <i>Lock/lock kit LT 40-08/50</i>
	134-022-00162	Kit movimento scatto/molla LT 40-08/50 <i>Lock/spring kit LT 40-08/50</i>
	134-022-00046	Tappo di conversione. <i>Conversion plug.</i>

ACCESSORI / ACCESSORIES

- **134-022-00019** Fiancata entrata + valvola max. / *Inlet cover + relief valve*
- **134-022-00028** Fiancata di scarico / *Outlet cover*
- **134-022-00037** Elemento leva completo parallelo / *Lever*
- **134-022-00304** Kit tiranti per 1 elemento / *Screws kit*
- **134-022-00313** Kit tiranti per 2 elementi / *Screws kit*
- **134-022-00322** Kit tiranti per 3 elementi / *Screws kit*
- **134-022-00331** Kit tiranti per 4 elementi / *Screws kit*
- **134-022-00340** Kit tiranti per 5 elementi / *Screws kit*
- **134-022-00359** Kit tiranti per 6 elementi / *Screws kit*

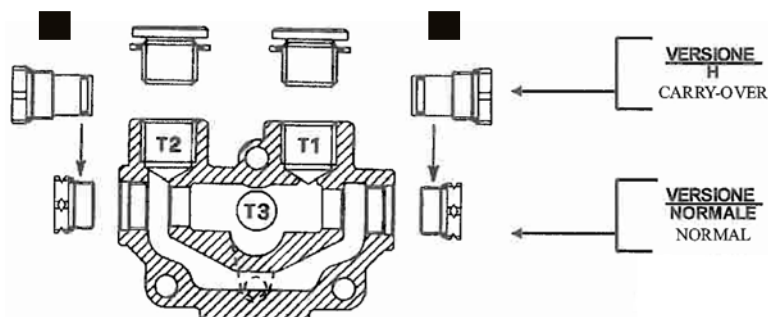

Sezione di fiancata di scarico LT 40/08 tipo CARRY-OVER con uscite T1 e T3 per collegamento in pressione a seguire e uscita T2 da collegare al serbatoio. Chiudere T2 in caso si utilizzi l'attacco sulla testata di entrata. Tutti i tappi raffigurati sono forniti di serie.

Outlet cover LT 40/08 CARRY-OVER type with ports T1 and T3 for pressure connection and port T2 for tank connection. Close T2 when using the tank port on the inlet cover. All the plugs shown are supplied as standard.

SCHEMA MONTAGGIO FIANCATA SCARICO CON TAPPI PER CARRY-OVER. PER OTTENERE IL CENTRO CHIUSO È SUFFICIENTE CHIUDERE L'ATTACCO T3 CON UN TAPPO DA 1/2 BSP

OUTLET COVER WITH SPECIAL PLUGS FOR CARRY-OVER VERSION. TO OBTAIN A CLOSED CENTER, SHUT-OFF PORT T3 WITH A 1/2 BSP PLUG.

Trasformazione fiancata scarico normale in tipo H
Instructions for change std outlet cover in carry-out style

134-022-00046

Tappi di conversione.
Conversion plug.

DISTRIBUTORI COMPOSTO "LT 50" A 1-2-3-4-5-6-7-8-9 LEVE DIRECTIONAL CONTROL VALVES "LT 50" WITH 1-2-3-4-5-6-7-8-9 LEVERS

CODICE FAMIGLIA
FAMILY CODE

134-019

LT 50

Codice fascicolo: 997-400-13410 Rev: AA

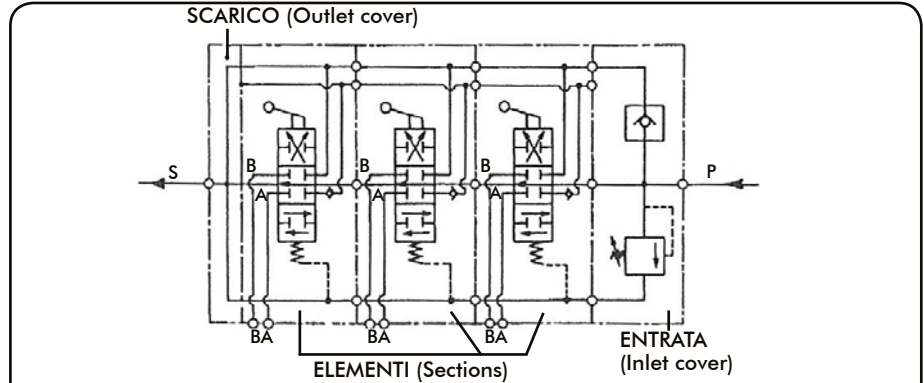







Perdite di carico / Head loss		
Portata Flow lt/min	Completo 1 leva 1 unit complete bar	Solo elemento Section only bar
70	2,2	1,3
62	1,8	1
50	1,3	0,8
37	1	0,3

Data: Venerdì 16 maggio 2014

Simbolo / Symbol	Descrizione / Description
P-P1	Pressione - Pressure
A-B	Utilizzi - Service ports
T1-T2-T3-T4	Scarico - Tank outlet
V	Regolazione press. max. Relief valve adjustmet

Tipo Type	Codice Code	Portata Flow l/min	Pressione Pressure bar	Dimensioni Dimension mm		Filettature disponibili Available thread				Peso Weight Kg
				F	G	P-P1	A-B	T	T1-T2-T2-T3-T4	
1 Leva - lever	134-019-00014	50	250	102,5	140	1/2" BSP	1/2" BSP	3/4" BSP	3/4" BSP	8,7
2 Leve - levers	134-019-00023			144,5	182					11,8
3 Leve - levers	134-019-00032			186,5	224					14,9
4 Leve - levers	134-019-00041			228,5	266					18
5 Leve - levers	134-019-00050			270,5	308					21,1
6 Leve - levers	134-019-00069			312,5	350					24,2
7 Leve - levers	134-019-00078			354,5	392					27,3
8 Leve - levers	134-019-00087			396,5	434					30,4
9 Leve - levers	134-019-00096			438,5	476					33,5

	CODICE/ CODE	DESCRIZIONE/DESCRIPTION
	134-020-00066	Elemento completo singolo <i>Single element assembly</i>
	134-020-00388	Kit servocomando pneumatico LT40/08-50 <i>Pneumatic servo control kit LT40/08-50</i>
	134-016-00491 134-016-00508	Kit elettrovalvole + raccordi per servocomando elettropneumatico 12V e 24V <i>Electropneumatic servo control kit 12V-24V</i>
	134-022-00108	Kit movimento scatto/scatto LT 40-08/50 <i>Lock/lock kit LT 40-08/50</i>
	134-022-00162	Kit movimento scatto/molla LT 40-08/50 <i>Lock/spring kit LT 40-08/50</i>
	134-020-00093	Tappo doppio scarico. <i>Double outlet plug.</i>

ALTRI ACCESSORI / OTHERS ACCESSORIES

- **134-020-00011** Fiancata entrata + valvola sicurezza / *Inlet cover+relief valve*
- **134-020-00084** Fiancata scarico / *Outlet cover*
- **134-020-00119** Mag. valvola 2° antiurto su A e B / *Valve*
- **134-020-00164** Mag. scatti 3 posizioni / *3 positions lock*
- **134-020-00306** Kit tiranti per 1 elemento / *Screws kit*
- **134-020-00315** Kit tiranti per 2 elementi / *Screws kit*
- **134-020-00324** Kit tiranti per 3 elementi / *Screws kit*
- **134-020-00333** Kit tiranti per 4 elementi / *Screws kit*
- **134-020-00342** Kit tiranti per 5 elementi / *Screws kit*
- **134-020-00351** Kit tiranti per 6 elementi / *Screws kit*
- **134-020-00360** Kit tiranti per 7 elementi / *Screws kit*

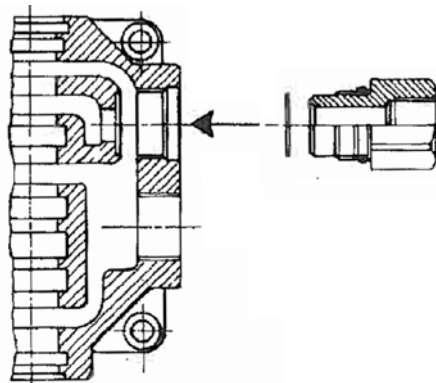

134-020-00093

**Tappo doppio scarico
Double outlet plug**

DISTRIBUTORI COMPOSTO "LT 120" A 1-2-3-4-5-6-7-8 LEVE DIRECTIONAL CONTROL VALVES "LT 120" WITH 1-2-3-4-5-6-7-8 LEVERS

CODICE FAMIGLIA
FAMILY CODE

134-023

LT 120

Codice fascicolo: 997-400-13410 Rev: AA

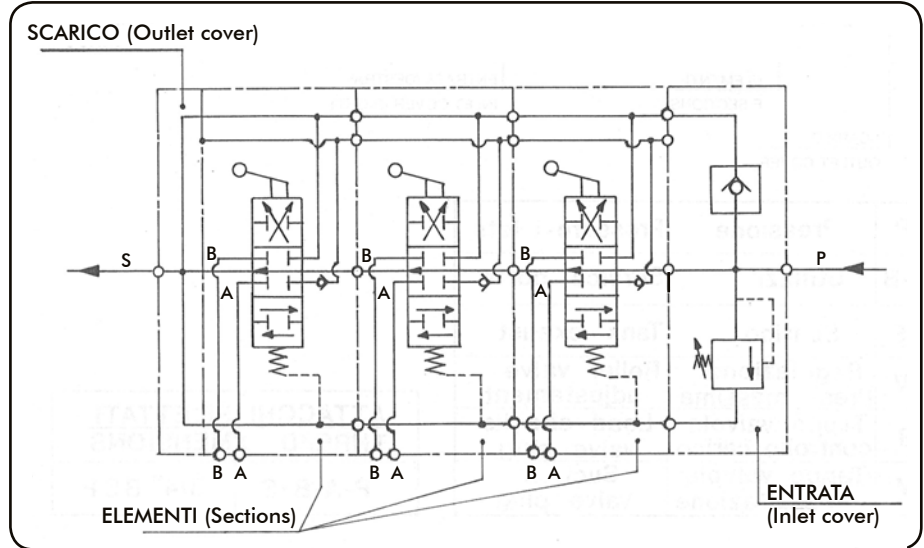

Data: Venerdì 16 maggio 2014

Simbolo / Symbol	Descrizione / Description
P	Pressione - Pressure
A-B	Utilizzi - Service ports
(S) T	Scarico - Tank outlet
R	Tappo vl. controllo carico - Load control valve plug
M	Tappo vl. anticavitazione - Suction valve plug
V	Regolazione press. max. - Relief valve adjustmet

Tipo Type	Codice Code	Portata Flow l/min	Pressione Pressure bar	Dimensioni Dimension mm		Filettature disponibili Available thread P-A-B-T	Peso Weight Kg
				F	G		
1 Leva - lever	134-023-00018	120	250	168	186	3/4" BSP	13,6
2 Leve - levers	134-023-00027			220	238		18,8
3 Leve - levers	134-023-00036			272	290		24
4 Leve - levers	134-023-00045			324	342		29,2
5 Leve - levers	134-023-00054			376	394		34,4
6 Leve - levers	134-023-00063			428	446		39,6
7 Leve - levers	134-023-00072			480	498		44,8
8 Leve - levers	134-023-00081			532	550		50

pag.21



O.M.F.B. S.p.A. Hydraulic Components
We reserve the right to make any changes without notice.
Edition 2011.09 No reproduction, however partial, is permitted.
Via Cave, 7/9 25050 Provaglio d'Iseo (Brescia) Italy Tel.: +39.030.9830611
Fax: +39.030.983207-208 Internet: www.omfb.it e-mail: info@omfb.it

COMPANY WITH
QUALITY SYSTEM
CERTIFIED BY DNV GL
= ISO 9001 =

	CODICE/ CODE	DESCRIZIONE/DESCRIPTION
	134-016-00035	Kit servocomando pneumatico LT 60/120 <i>Pneumatic servo control kit LT 60/120</i>
	134-016-00491 134-016-00508	Kit elettrovalvole + raccordi per servocomando elettropneumatico 12V e 24V <i>Electropneumatic servo control kit 12V-24V</i>
	134-016-00099 134-016-00106	Bobina 12V o 24V per servocomando. <i>Coil</i>
	134-016-00197	Kit servocomando eletroidraulico 24V <i>Electrohydraulic 24V kit</i>
	134-016-00204	Valvola contropressione scarico per servocomando eletroidraulico. <i>Back-pressure valves</i>
	134-016-00017	Kit movimento scatto/scatto LT 60/120 <i>Lock/lock kit LT 60/120</i>
	134-016-00179	Kit movimento scatto/molla LT 60/120 <i>Lock/spring kit LT 60/120</i>
	134-016-00151	Gruppo leva completo <i>Assembly lever group</i>
	134-016-00446	Leva nuda + pomello <i>Lever + knob</i>

	CODICE/ CODE	DESCRIZIONE/DESCRIPTION
	134-024-00035	Elemento completo singolo <i>Single element</i>
	134-024-00044	Fiancata scarico <i>Outlet cover</i>
	134-024-00053	Fiancata entrata + valvola sicurezza <i>Inlet cover + relief valve</i>

ALTRI ACCESSORI / OTHERS ACCESSORIES

134-024-00302	Kit tiranti per 1 elemento / Screws kit
134-024-00311	Kit tiranti per 2 elementi / Screws kit
134-024-00320	Kit tiranti per 3 elementi / Screws kit
134-024-00339	Kit tiranti per 4 elementi / Screws kit
134-024-00348	Kit tiranti per 5 elementi / Screws kit
134-024-00357	Kit tiranti per 6 elementi / Screws kit

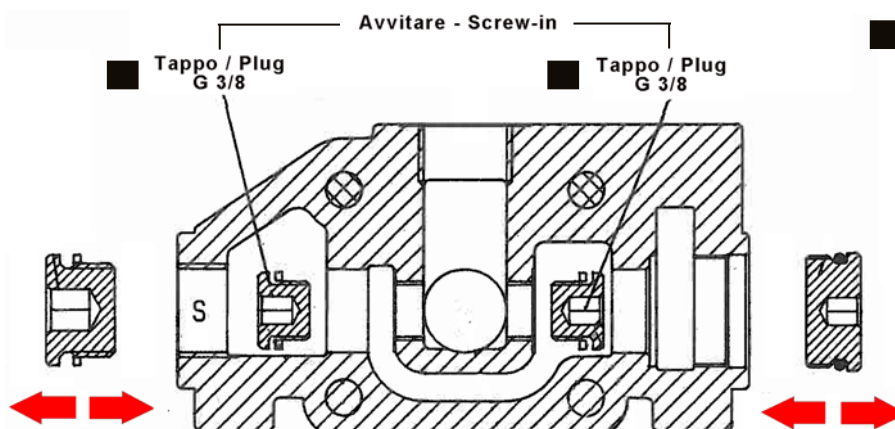



Trasformazione fiancata scarico normale in tipo H
Instructions for change std outlet cover in carry-out style

SCHEMI DEI CURSORI DISPONIBILI

LAYOUTS OF AVAILABLE PILOT SHAFTS

Codice fascicolo: 997-400-13410 Rev: AA

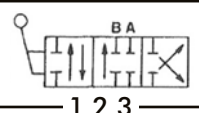
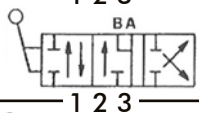
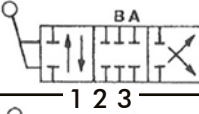
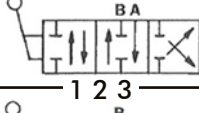
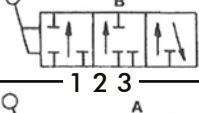
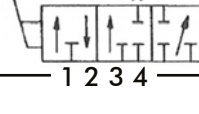
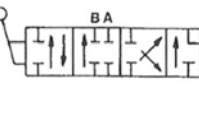
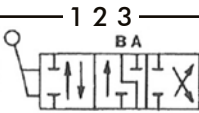
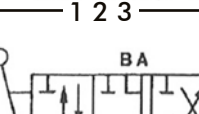
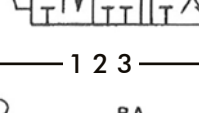
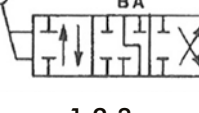
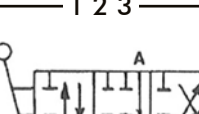
Data: Venerdì 16 maggio 2014

SIGLA CODE	SCHEMA LAYOUT	CARATTERISTICHE FEATURES
A		Cursore a centro aperto (P→S) in posizione centrale. Utilizzi chiusi. A leva spinta P→A, B→S. A leva tirata P→B, A→S. Centre pilot shaft open (P→S) in central position. Service ports closed. With lever pushed P→A, B→S. With lever pulled P→B, A→S.
C		Cursore a centro aperto (P→S) in posizione centrale. Utilizzi allo scarico. A leva spinta P→A, B→S. A leva tirata P→B, A→S. Centre pilot shaft open (P→S) in central position. Service ports in discharge. With lever pushed P→A, B→S. With lever pulled P→B, A→S.
D		Cursore a centro chiuso (P→) in posizione centrale. Utilizzi chiusi. A leva spinta P→A, B→S. A leva tirata P→B, A→S. Ottenibile anche montando sullo scarico il tappo D. Centre pilot shaft closed (P→) in central position. Service ports closed. With lever pushed P→A, B→S. With lever pulled P→B, A→S. Also obtainable by mounting plug D on outlet.
B		Cursore a centro aperto (P→S) in posizione centrale. Utilizzo B chiuso, utilizzo A allo scarico. A leva spinta P→S, B→S. A leva tirata P→B, A→S. Centre pilot shaft open (P→S) in central position. Service port B closed, service port A in discharge. With lever pushed P→S, B→S. With lever pulled P→B, A→S.
E		Cursore a centro aperto (P→S) in posizione centrale per cilindri a semplice effetto. Utilizzo chiuso. A leva spinta P→B→S. A leva tirata P→B. Centre pilot shaft open (P→S) in central position for single-acting cylinders. Service port closed. With lever pushed P→B→S. With lever pulled P→B.
F		Cursore a centro aperto (P→S) in posizione centrale per cilindri a semplice effetto. Utilizzo chiuso. A leva spinta P→A. A leva tirata P→A→S. Centre pilot shaft open (P→S) in central position for single-acting cylinders. Service port closed. With lever pushed P→A. With lever pulled P→A→S.
G		Cursore a centro aperto (P→S) in posizione centrale. Utilizzi chiusi. Per cilindri a doppio effetto con IV posizione flottante. A leva spinta P→A, B→S, a leva ulteriormente spinta A→B→S con aggancio di ritenuta. A leva tirata P→B, A→S. Centre pilot shaft open (P→S) in central position. Service ports closed. For double-acting cylinders with 4th pos. floating. With lever pushed further P→A, B→S with lever pushed further A→B→S with engage. With lever pulled P→B, A→S.
I		Cursore a centro aperto (P→S) in posizione centrale. Utilizzo A chiuso. Utilizzo B a scarico. A leva spinta P→A, B→S. A leva tirata P→B, A→S. Centre pilot shaft open (P→S) in central position. Service port A closed. Service port B in discharge. With lever pushed P→A, B→S. With lever pulled P→B, A→S.
M		Cursore a centro chiuso in posizione centrale. Utilizzi allo scarico. A leva spinta P→A, B→S. A leva tirata P→B, A→S. Ottenibile anche montando sullo scarico il tappo D con cursore tipo C. Centre pilot shaft closed in central position. Service ports in discharge. With lever pushed P→A, B→S. With lever pulled P→B, A→S. Also obtainable by mounting plug D on outlet with type C pilot.
N		Cursore a centro chiuso. In posizione centrale utilizzo B allo scarico. Utilizzo A chiuso. A leva spinta P→A, B→S. A leva tirata P→B, A→S. Ottenibile anche montando sullo scarico il tappo D con cursore tipo C. Centre pilot shaft closed in central position. Service port B in discharge. Service port A closed. With lever pushed P→A, B→S. With lever pulled P→B, A→S. Also obtainable by mounting plug D on outlet with type C pilot.
O		Cursore a centro chiuso. In posizione centrale utilizzo A allo scarico. Utilizzo B chiuso. A leva spinta P→A, B→S. A leva tirata P→B, A→S. Ottenibile anche montando sullo scarico il tappo D con cursore tipo C. Centre pilot shaft closed in central position. Service port A in discharge. Service port B closed. With lever pushed P→A, B→S. With lever pulled P→B, A→S. Also obtainable by mounting plug D on outlet with type C pilot.
P		Cursore a centro aperto per cilindri a semplice effetto o motori unidirezionali, in posizione centrale utilizzo B a scarico. A leva tirata P→B. Centre pilot shaft open in central position for single-acting cylinders or unidirectional motors. Service port B in discharge, with lever pulled P→B.
Q		Cursore a centro aperto per cilindri a semplice effetto o motori unidirezionali, in posizione centrale utilizzo A a scarico. A leva tirata P→A. Centre pilot shaft open in central position for single-acting cylinders or unidirectional motors. Service port A in discharge, with lever pulled P→A.

SCHEMI DEI TIPI DI AZIONAMENTO

DIAGRAMS OF OPERATION TYPES

SIGLA CODE	SCHEMA LAYOUT	CARATTERISTICHE FEATURES
13R2		Posizione 2: stabile. Posizioni 1-3: ritorno molla in posizione 2. <i>Position 2: stable. Positions 1-3: spring return in position 2.</i>
1R3		Posizione 3: stabile. Leva normalmente rientrata, tirando la leva vado in posizione 1. Transitorio aperto=213-C - Transitorio chiuso=213-D <i>Position 3: stable. Lever normally pushed in. Pull lever to go in position 1. Transient open=213-C - Transien closed=213-D</i>
1R2		Posizione 2: stabile. Tirando la leva vado in posizione 1. Rilasciando torna in posizione 2. <i>Position 2: stable. Pull lever to go to position 1. Release to return to position 2.</i>
3R2		Posizione 2: stabile. Spingendo la leva vado in posizione 3. Rilasciando torna in posizione 2. <i>Position 2: stable. Push lever to go to position 3. Release to return to position 2.</i>
3R1BC/BD		Posizione 1: stabile. Leva normalmente fuori. Spingendo la leva vado in posizione 3. Transitorio aperto=213/B-C - Transitorio chiuso=213/B-D <i>Position 1: stable. Lever normally pulled out. Push lever to go to position 3. Transient open=213/B-C - Transien closed=213/B-C</i>
2R1		Posizione 1: stabile. Leva normalmente fuori. Spingendo la leva vado in posizione 2. Rilasciando torna in posizione 1. <i>Position 1: stable. Lever normally pulled out. Push the lever to go to position 2. Release to return to position 1.</i>
2R3		Posizione 3: stabile. Leva normalmente dentro. Tirando la leva vado in posizione 2. Rilasciando torna in posizione 3. <i>Position 3: stable. Lever normally pushed in. Pull lever to go to position 2. Release to return to position 3.</i>
123		Ritenuta a scatti nelle 3 posizioni. <i>Three position locking.</i>
13CD		Ritenuta a scatti nelle posizioni estreme. Transitorio aperto=4C. Transitorio chiuso=4D. <i>Locked in last position. Transien open=4C. Transien closed=4D.</i>
23		Ritenuta a scatti nelle posizioni 2-3 posizione centrale e la leva spinta stabili. <i>Locked in positions 2-3. Lever pushed in and central position stable.</i>
12		Ritenuta a scatti nelle posizioni 1-2 posizione centrale e a leva tirata stabili. <i>Locked in positions 1-2. Lever pulled and central position stable.</i>
3S1R2		Ritenuta a scatti in posizione 3 a leva spinta. Posizione centrale 2 stabile. Posizione 1 con leva tirata con ritorno a molla in posizione 2. <i>Locked in position 3 with lever pushed in. Central position 2 stable. Position 1 with lever pulled and spring return to position 2.</i>
13R2P		Azionamento con servocomando pneumatico posizione 2 stabile. Posizioni estreme 1-3 con ritorno al centro. <i>Operation with pneumatic servo-control. Position 2 stable. End positions 1-3 with return to center.</i>
1234		Ritenuta a scatti nelle 4 posizioni. E' possibile solo con cursore tipo G. <i>Locked in 4 positions. Only possible with type G pilot shaft.</i>
13R20		Azionamento con servocomando oleodinamico. Posizione 2 stabile. Posizioni 1-3 con ritorno a molla in posizione 2 (senza leva di azionamento). <i>Operation with hydraulic servo-control. Position 2 stable. Positions 1-3 with spring return to position 2 (without control lever).</i>
1S3R2		Ritenuta a scatti in posizione 1 a leva tirata. Posizione centrale 2 stabile. Posizione 3 a leva spinta con ritorno a molla al centro. <i>Locked in position 1 with lever pulled. Central position 2 stable. Position 3 with lever pushed and spring return to center.</i>