



**库威得**  
KUDOSWORLD



# HYDRODYNAMIC COUPLING

TK-N  
KWN 29000



**Product | Engineering Services  
Maintenance**

## Technical Features

Hydrodynamic couplings belong to the group of hydrodynamic power transmission devices.

The power transmission is done by mass forces of the operation liquid according to the "Frottinger Prinzip". The impeller pump absorbs the mechanical power of the drive and increases the energy of the circulating operating liquid. The turbine wheel takes energy away from the operating liquid and outputs mechanical power. There is not any fixed connection between both wheels. Slight power losses, caused by the for the power transmission necessary slippage, will be transformed to heat.

The permissible ambient temperature range of the hydrodynamic coupling in standard design is between  $-25^{\circ}\text{C}$  ~  $+40^{\circ}\text{C}$  (other values on request).

## Hydrodynamic Couplings Are Distinguished by

1. Power transmission free of wear.
2. Steady shock free start up in loaded or unloaded state.
3. Slight backlash on the electrical power supply due to fast abating of the start up current and low start up current.
4. Load compensation on multi motor drives.
5. Efficient decoupling of vibration systems.
6. Damping of shocks, vibration and load changes.
7. Protection against thermal overload by the installed fusible plug or by a mechanical or electronical switch off device.

## Specification

1. With elastic coupling.
2. With elastic coupling and brake wheel.
3. With elastic coupling and brake disc.
4. With enlarged delay chamber.
5. Radial removable, motor or driven device displacement is not required to move.
6. hydrodynamic coupling with two hydrodynamic units for high power.
7. With v-belt pulley.
8. Diesel driven driving device.
9. Vertical mounted drive device.
10. Water medium hydraulic coupling.

## Typical Applications

1. Accelerating of large masses for example at mills, centrifuges, mixer, blower, wood working, machines, sieves, ball mills, rope machinery and tool machinery.
2. Start up against high break off torques for example mixer, conveyors, breakers, centrifuges and pumps.
3. Soft start up at tip and adjustment operation on large mobile equipment.
4. Safe overload protection for example at dredgers, breakers and scoop wheels.

## Types

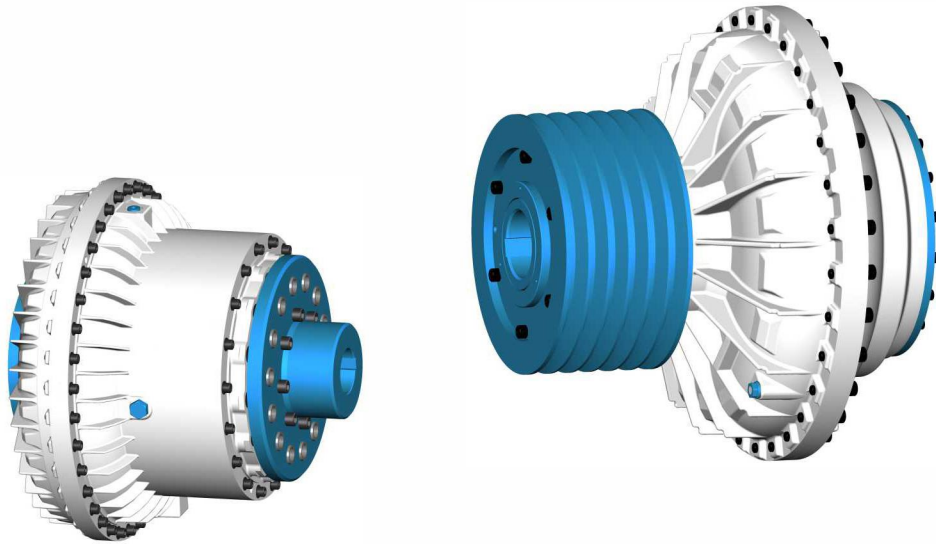

- Type HR  
hydrodynamic coupling without delay chamber
- Type HR-C  
hydrodynamic coupling with delay chamber
- Type HR-CC  
hydrodynamic coupling with enlarged delay chamber
- Type HR-D  
hydrodynamic coupling with two hydrodynamic units
- Type HR-B, HR-CB, HR-CCB,HR-DB  
hydrodynamic couplings of the type HR,HR-C, HR-CC, HR-D with brake drum according to DIN 15431
- Type HR-S, HR-CS, HR-CCS, HR-DS  
hydrodynamic couplings of the type HR. HR-C,HR-CC, HR-D with brake disk according to DIN 15432
- Type HR-P, HR-CP HR-CCP  
hydrodynamic couplings of the type HR, HR-C, HR-CC with pulley





## Installation and Operating Conditions

### 1. Selection of the coupling

The first coupling selection can be done according to the power characteristics given on page 4. In case of the wish of a selection done by the manufacturer please use the questionnaire.

### 2. Possible installation placements

Hydrodynamic couplings can operate in both rotation directions and can be installed like follow described:

mounting on the motor shaft/ gearbox shaft

The drive takes place on the outer wheel, which following Advantages:

- The power transmission of the hydrodynamic coupling increased due to the fact optimized circuit
- The hydrodynamic coupling can be thermally stability operate
- The installed temperature monitoring system delivers always clear signals.

### 3. Special designs for vertical installation of the hydrodynamic coupling are available.

### 4. Notice

The assembly of the hydraulic coupling shall be in accordance with the steps in the installation and maintenance manual. Poor assembly results in a significant impact on the position of the elastic couplings (model HR, HR-B and HR-S) during the service life and a reactive force on these types of elastic couplings.



# Power Characteristics

Power characteristics for one hydrodynamic unit(outer drive)

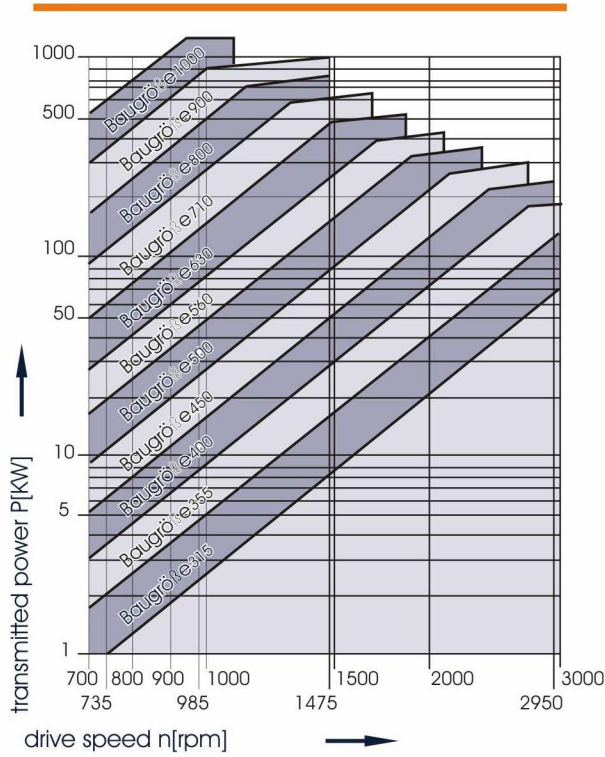

Power characteristics for two hydrodynamic units (outer drive)

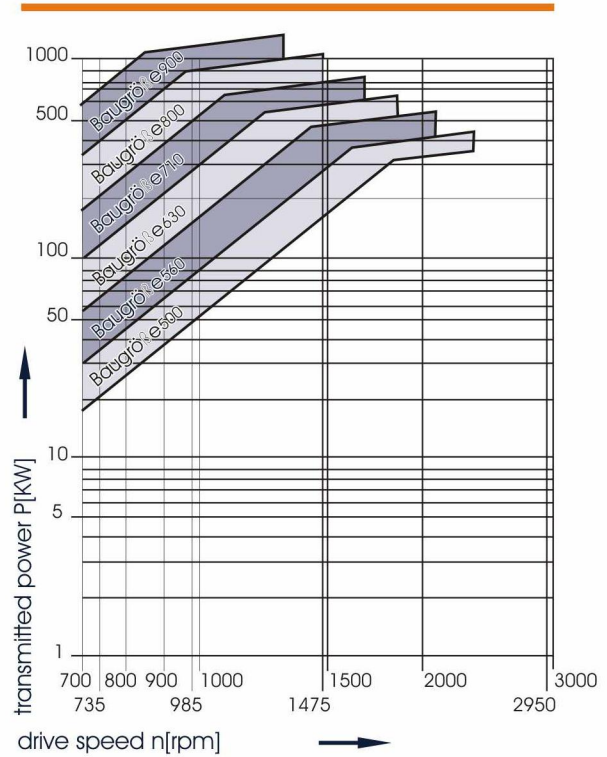

Power characteristics for one hydrodynamic unit( internal drive)

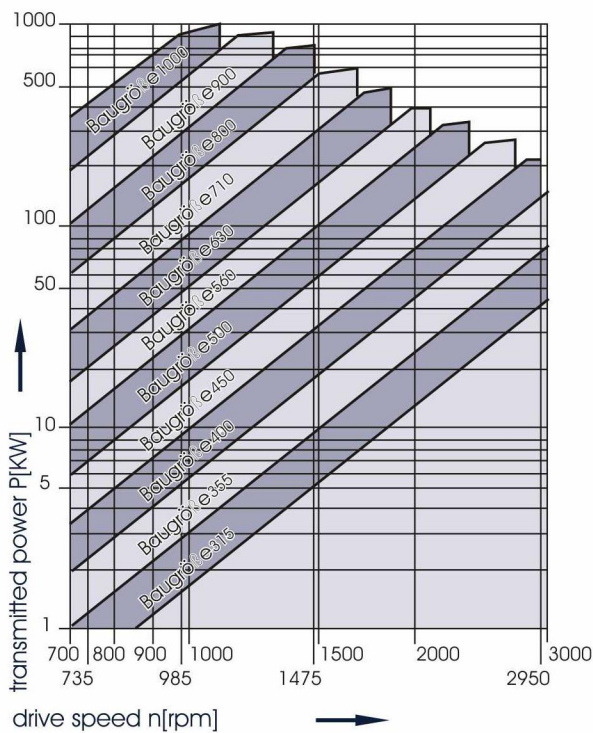

Example for selection (for size 560)

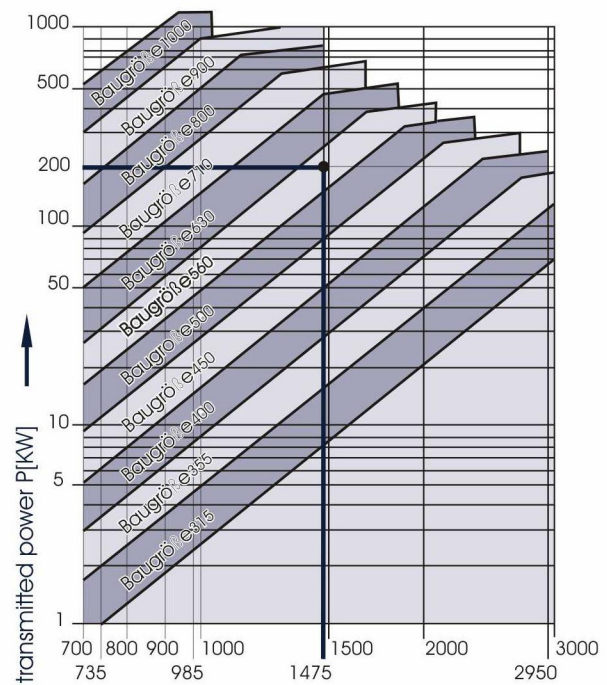

hydrodynamic coupling for an outer drive standard design (one hydrodynamic unit )  
 drive speed  $n=1475\text{rpm}$   
 transmitted power  $P_{\text{nominal}}=200\text{KW}$

## Type HR-C

- hydrodynamic coupling with delay chamber

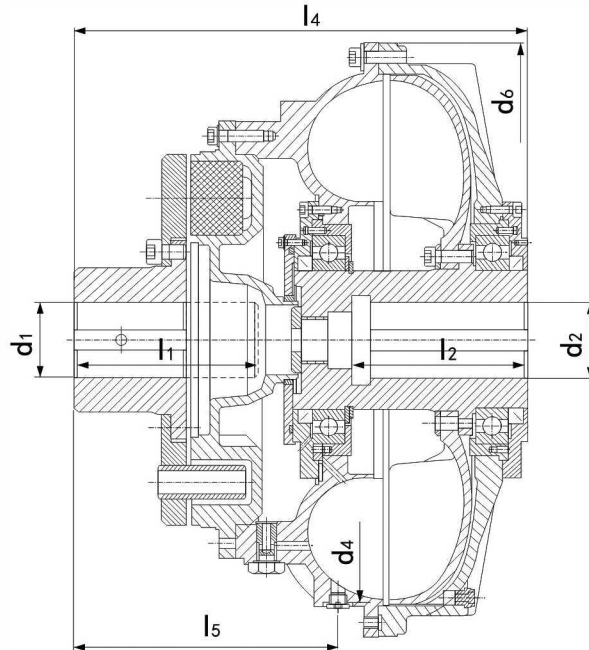
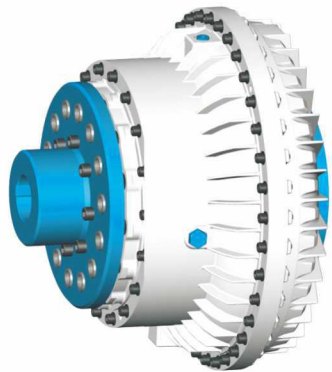

### Ordering example: HR-C 560-65 H7-70 H7 x 140

Designation of a hydrodynamic coupling type HR-C, nominal size 560, bore of the flexible connection coupling  $d_1=65$  H7, bore of the hydrodynamic coupling  $d_2=70$  H7, for shaft length  $l_2=140$  mm

Main dimensions

Table 1

size	$d_1^{(1)}$	$d_1^{(1)}$	$d_4$	$d_6$	$l_1^{(2)}$	$l_2^{(2)}$	$l_4^{(4)}$	$l_5$	speed	mass <sup>3)</sup>
									$n_{max}$ [rpm]	$m$ [kg]
274	60	50	272	328	140	110	299,5	177,0	3600	30
355	85	55	366	424	125	110	309,0	159,0	3600	45
400	85	70	396	470	145	125	365,0	189,0	3000	65
450	85	85	456	540	145	165	390,0	196,0	1740	75
500	95	95	484	575	165	165	427,0	204,0	1740	90
560	110	110	572	640	170	170	489,0	279,0	1740	175
630	110	120	646	710	200	170	546,0	336,0	1740	210
710	140	125	725	820	230	210	606,0	335,5	1740	330
800	140	150	832	930	260	220	651,0	354,0	1475	450
900	165	160	890	1050	300	260	750,0	441,0	1475	620
1000	165	160	1000	1118	200	280	676,5	292,5	1200	750

## Type HR-CC

- hydrodynamic coupling with enlarged delay chamber

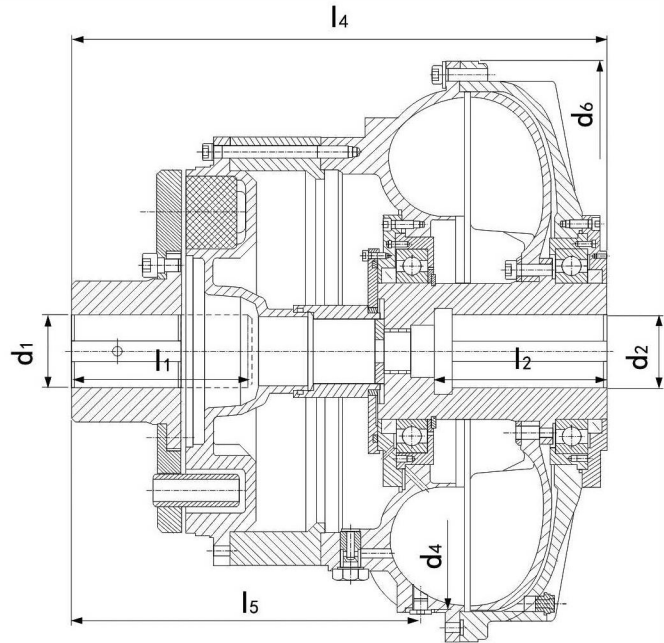
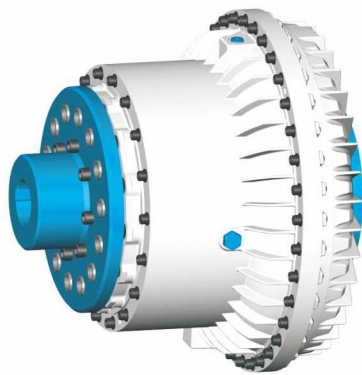

### Ordering example: HR-CC 560-65 H7-70 H7 x140

Designation of a hydrodynamic coupling type HR-CC, nominal size 560, bore of the flexible connection coupling  $d_1=65$  H7, bore of the hydrodynamic coupling  $d_2=70$  H7, for shaft length  $l_2=140$ mm.

Main dimensions

Table 2

size	$d_1^{(1)}$	$d_1^{(1)}$	$d_4$	$d_6$	$l_1^{(2)}$	$l_2^{(2)}$	$l_4^{(4)}$	$l_5$	speed $n_{max}$ [rpm]	mass <sup>3)</sup> m [kg]
274	60	50	272	328	140	110	339,5	217,0	3600	32,0
355	85	55	366	424	125	110	386,0	236,5	3600	51,4
400	85	70	396	470	145	125	479,5	303,5	3000	75,2
450	85	85	456	540	145	165	504,5	310,5	1740	85,2
500	95	95	484	575	165	165	541,5	318,5	1740	100,2
560	110	110	572	640	170	170	589,0	379,0	1740	188,8
630	110	120	646	710	200	170	646,0	436,0	1740	223,8
710	140	125	725	820	230	210	731,0	460,5	1740	356,6
800	140	150	832	930	260	220	776,0	479,0	1475	476,6
900	165	160	890	1050	300	260	900,0	591,0	1475	680,0
1000	165	160	1000	1118	200	280	845,5	461,5	1200	830,0



### Type HR-D

- hydrodynamic coupling with two hydrodynamic units

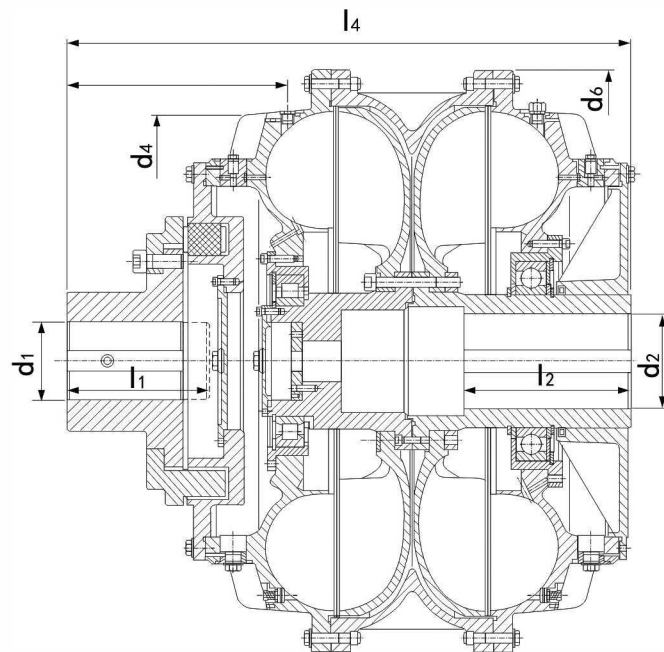
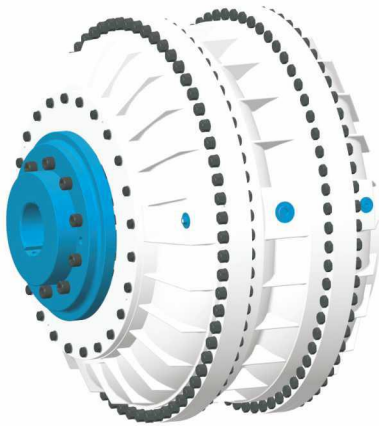

### Ordering example: HR-D 560 -65 H7-70 H7 140

Designation of a hydrodynamic coupling type HR- D nominal size 560, bore of the flexible connection coupling  $d_1=65$  H7, bore of the hydrodynamic coupling  $d_2=70$  H7, for shaft length  $l_2=$  mm

Main dimensions

Table 3

size	$d_1^{1)}$	$d_2^{1)}$	$d_4$	$d_6$	$l^{2)}$	$l_2^{2)}$	$l_4^{4)}$	$l_5$	speed $n_{max}$ [rpm]	mass <sup>3)</sup> $m$ [kg]
500	95	95	484	575	165	170	550	204,0	1740	125
560	110	110	572	640	170	210	570	279,0	1740	245
630	110	120	646	710	200	210	630	336,0	1740	300
710	140	125	725	820	230	250	650	335,5	1740	460
800	140	150	832	930	260	250	715	354,0	1475	630
900	165	160	890	1050	300	300	900	441,0	1475	870
1000	165	160	1000	1118	200	300	980	292,5	1200	1050

### Type HR-P, HR-CP, HR-CCP

- hydrodynamic couplings of the type HR, HR-C, HR-CC with pulley

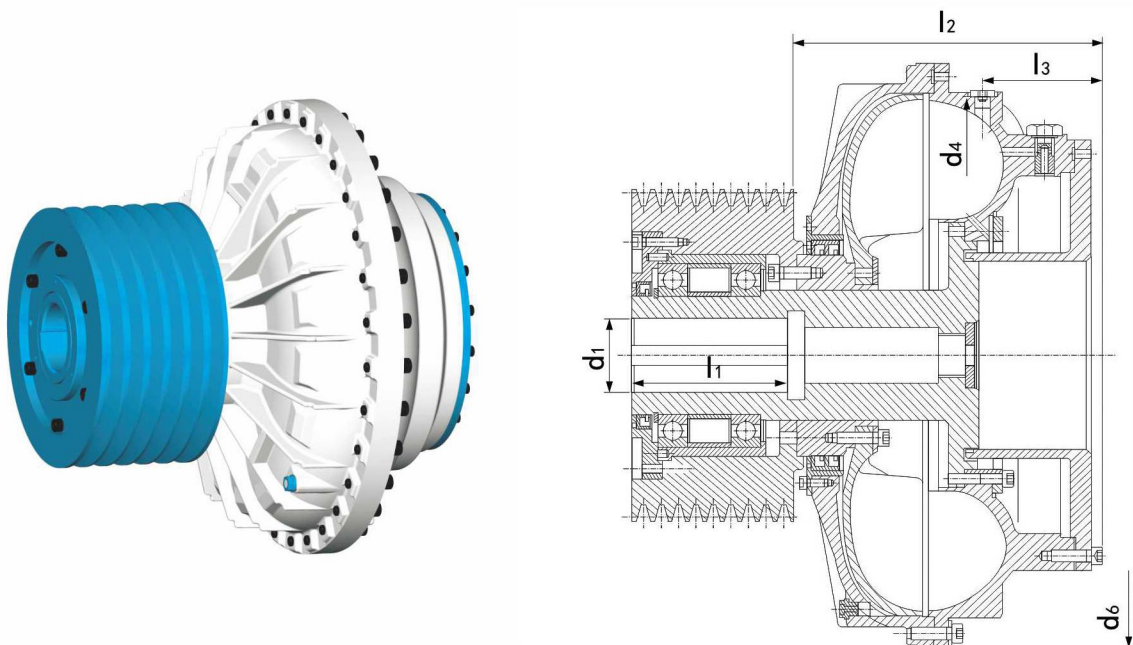

### Ordering example: HR-CP 560-70 H7 x 140 KRS400-8 x SPC

Designation of a hydrodynamic coupling type HR-CP, nominal size 560, bore of the hydrodynamic coupling  $d_1 = 70$  H7, for shaft length  $l_1 = 140$  mm, pulley diameter  $d_w = 400-8$  grooves with profile SPC

Main dimensions

Table 4

size	$d_4$	$d_6$	TK-N-K		TK-N-KV		TK-N-KVZ		mass <sup>6)</sup> m [kg] TK-N-K	mass <sup>6)</sup> m [kg] TK-N-KV TK-N-KVZ
			$l_2$	$l_3$	$l_2$	$l_3$	$l_2$	$l_3$		
274	272	328	152	25,0	192,0	65,0	192,0	65,0	30	32
355	366	424	220	65,0	297,5	142,5	297,5	142,5	45	51
400	396	470	276	95,0	390,5	209,5	390,5	209,5	65	75
450	456	540	301	102,0	415,5	216,5	415,5	216,5	75	85
500	484	575	338	110,0	452,5	224,5	452,5	224,5	90	100
560	572	640	316	123,0	416,0	223,0	416,0	223,0	175	189
630	646	710	353	160,0	453,0	260,0	453,0	260,0	210	224
710	725	820	415	142,5	540,0	267,5	540,0	267,5	330	357
800	832	930	460	164,0	585,0	289,0	585,0	289,0	450	477
900	890	1050	523	218,0	673,0	268,0	673,0	368,0	620	680
1000	1000	1118	538	178,0	707,0	347,0	707,0	347,0	750	830

### Type HR-B, HR-CB, HR-CCB, HR-DB

- hydrodynamic couplings of the type HR. HR-C, HR-CC, HR-D with brake drum according to DIN15431

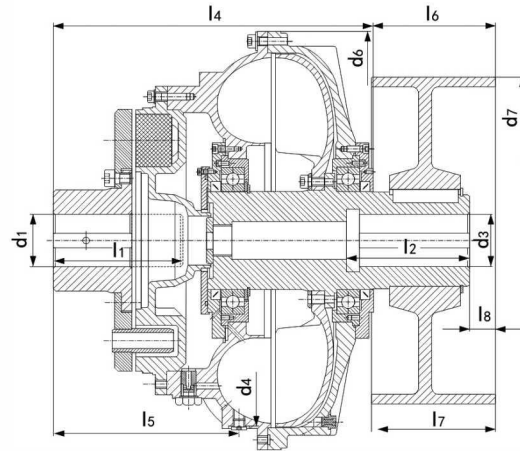
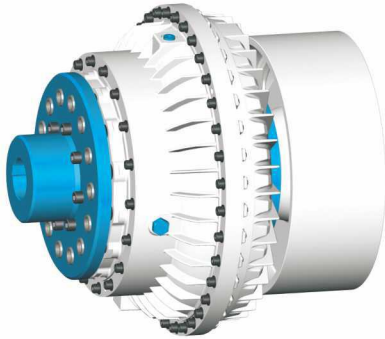

Ordering example: HR-CB 560-65 H7-70 H7x140-500x 190

Designation of a hydrodynamic coupling type HR-CB, nominal size 560, bore of the flexible connection coupling  $d_1=65$  H7, bore of the hydrodynamic coupling  $d_3=70$  H7, for shaft length  $l_2=140$  mm, brake drum 500 x 190 mm

Main Dimensions/Characteristic Values

Table 5

size	brake drum $d_7$	$d_3^{1)}$	$l_6$	$l_7$	$l_8$	speed $n_{max}$ [rpm]	mass <sup>5)</sup> m [kg]
274	200	40	83	75	0	3600	39
	250	40	103	95	20	3600	47
	315	40	126	118	43	3600	59
355	200	50	83	75	0	3600	54
	250	50	103	95	20	3600	62
	315	50	126	118	43	3600	74
400	250	70	106	95	23	3000	82
	315	70	156	118	46	3000	94
	400	70	216	150	78	3000	117
450	315	70	152	118	46	1740	104
	400	70	216	150	78	1740	127
	500	70	256	190	118	1740	167
500	315	70	152	118	46	1740	119
	400	70	216	150	78	1740	142
	500	70	256	190	118	1740	182
560	400	100	207	150	80	1740	227
	500	100	287	190	120	1740	267
	630	100	333	235	166	1740	349
630	500	110	234	190	70	1740	302
	630	110	276	236	101	1740	384
	710	110	305	265	130	1740	472
710	500	125	243	190	70	1740	422
	630	125	265	236	80	1740	504
	710	125	318	265	84	1740	592
800	500	125	192	190	10	1475	542
	630	125	237	236	56	1475	624
	710	125	315	265	75	1475	712
900	500	140	192	190	11	1475	712
	630	140	237	236	57	1475	794
	710	140	315	265	75	1475	882
1000	710	160	315	265	75	1200	1012



### Type HR-S, HR-CS, HR-CCS, HR-DS

- hydrodynamic couplings of the type HR. HR-C, HR-CC, HR-D with brake drum according to DIN15431

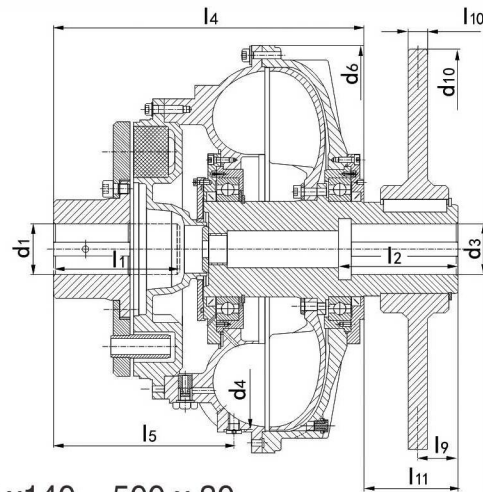
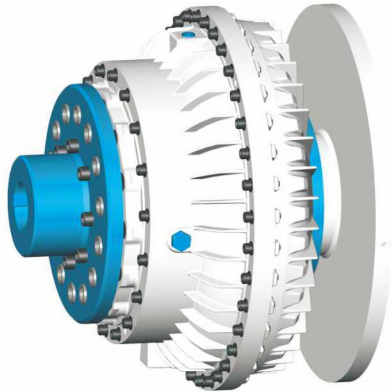

Ordering example: HR-CS 560-65 H7-70 H7 x140 - 500 x 30

Designation of a hydrodynamic coupling type HR-CS, nominal size 560, bore of the flexible connection coupling  $d_1=65$  H7, bore of the hydrodynamic coupling  $d_2=70$  H7, for shaft length  $l_2=140$  mm, brake disk 500 x 30 mm

Main Dimensions/Characteristic Values

Table 6

size	brake disk $d_{10}$	$d_3^{1)}$	$l_9$	$l_{10}$	$l_{11}$	speed $n_{max}$ [rpm]	mass <sup>5)</sup> m [kg]
274	200	40	18	15	75	3600	36
	355	40	19	15	75	3600	46
	400	40	30	30	75	3600	51
355	200	50	18	15	75	3600	52
	355	50	19	15	75	3600	62
	400	50	30	30	75	3600	67
400	355	70	19	15	100	3000	85
	400	70	30	30	100	3000	90
	450	70	30	30	100	3000	95
450	400	70	30	30	100	1740	102
	450	70	30	30	100	1740	107
	500	70	30	30	100	1740	113
500	400	70	30	30	125	1740	117
	450	70	30	30	125	1740	122
	500	70	30	30	125	1740	128
560	450	100	30	30	125	1740	207
	500	100	30	30	125	1740	219
	630	100	35	30	125	1740	238
630	500	110	30	30	125	1740	254
	630	110	30	30	125	1740	401
	710	110	35	30	125	1740	553
710	500	125	30	30	170	1740	386
	630	125	30	30	170	1740	404
	710	125	35	30	170	1740	444
800	500	125	30	30	170	1475	512
	630	125	30	30	170	1475	530
	710	125	35	30	170	1475	569
900	630	140	30	30	170	1475	706
	710	140	30	30	170	1475	749
	800	140	35	30	170	1475	770
1000	800	160	35	30	170	1200	900

## Scope of Delivery

### Type HR, HR-C, HR-CC, HR-D

1. Standard fusible plug (140°C) , assembled in the coupling.
2. Exchangeable standard nozzle set beginning with nominal size 560, assembled in the coupling.
3. Fixing elements ( hexagon screw, disk and spring washer), loosely supplied.

### Type HR-P, HR-CP, HR-CCP

1. Pulley type and dimension according to customers request mounted on the coupling.
2. Standard fusible plug(140°C) , assembled in the coupling.
3. Exchangeable standard nozzle set beginning with nominal size 560, assembled in the coupling.
4. Fixing elements ( hexagon screw, disk and spring washer ) , loosely supplied.

### Type HR-B, HR-CB, HR-CCB, HR-DB & HR-S,HR-CS, HR-CCS, HR-DS

- 1.Brake drum or brake disk, in dimension and type according to customers request, possibly with connection elements, mounted on the coupling.
- 2.Standard fusible plug (140°C) , assembled in the coupling.
3. Changeable standard nozzle set beginning with nominal size 560, assembled in the coupling.
4. Fixing elements ( hexagon screw, disk and spring washer), loosely supplied.

## Recommended materials for brake drum and brake disks

Material	Remark	Recommended utilization case
EN-GJL-250 DIN EN 1561	high frictional coefficient、 low permissible speed、 low wear	holding and service brakes
EN-GJS-400-15U DIN EN 1563 EN-GJS-700-2U DIN EN 1563	low frictional coefficient very good wearing properties	service brake
GE 300 DIN EN 10293 hard chromium plate	minimum of 300 Brinell hardness decrease in frictional coefficient at high temperatures	service brake
GE 300 DIN EN 10293 hardened	minimum of 300 Brinell hardness high frictional coefficient over a wide range of temperature good temperature stability of frictional coefficient wear	holding brakes and service brakes at high temperatures
GE 300 DIN EN 10293 untreated	average frictional coefficient low surface solidity leads to pickup and thus to a high level of wear	holding brake

## Balance

The couplings will be dynamically balanced. Standard balancing quality is Q6,3 at 1500rpm according to VDI 2060 in two planes. Other balancing qualities possible. Please contact us.

## Operation Liquid

### Operation liquid

The operation liquid has to have the following characteristic values:

Table 7

kinematic viscosity at 40°C	27–60 cSt
density at 20°C	0.85–0.91 g/cm <sup>3</sup>
flashing point	170°C
solidification point	–25°C at outside operation
water conten	0.1%
tendency towards foaming	low

### Recommended oils

Followings sorts of oil are useable:

Table 8

oil brand	oil type
Addinol	H 46 R/TL 36
BP Oil	HL 32/HL 22
Deutsche Shell	Shell Tellus 32
Winter shall AG	Wiolan HF 32
Mobil Oil AG	Mobilfluid 120
Deutsche Total GmBH	Total Azolla 32
Esso AG	Torque Fluid N 45
DEA Mineralöl AG	Astron HLP 32

Hydrodynamic couplings with special working conditions or by using different sorts of oil, please contact us.

### Quantities of oil

The oil quantity depends on the type of coupling and the transmitted drier power. Further information concerning oil fill level are available in coupling installation instruction. System related adjustments have to align on site.

### Operating medium water

Hydrodynamic couplings can also with a water glycol mixture can be operated. The advantages of this equipment are the cost-effective procurement and Presence of increased environmental regulations. Construction of this Input use an additional encapsulation of the bearings. The rolling bearings can no longer be on the made oil fill, but is a lifetime grease ensured.



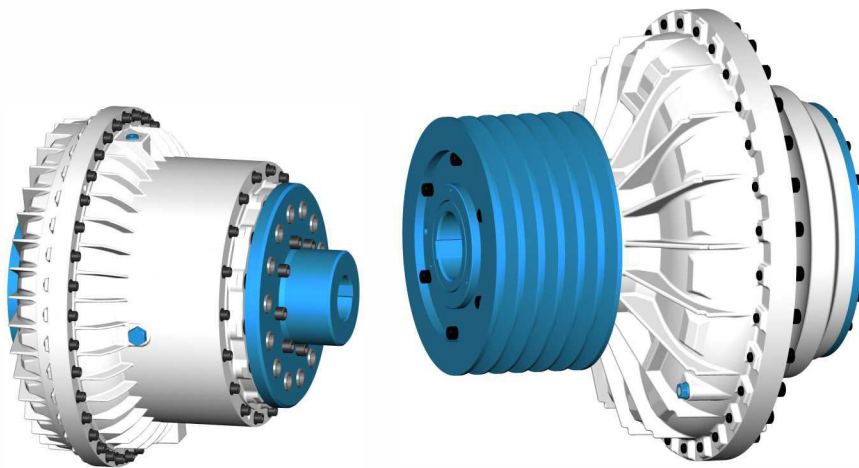

## Optional Accessory

### Insert Bushings

By using of insert couplings of the same size and type can be adapted to different shaft diameter and shaft length. The insert bushing can be delivered in pilot and finished bore for the insert bushings intended types on request.

### Protection cover

In order to protect staff against unintentional touch of the rotating parts of the hydrodynamic coupling a protection cover is necessary. The design of the cover has to be made in such a way that the cooling of the coupling by an air circulation is guaranteed. Covers in standard or special design are available on request.

### Mechanical thermal switch off device

Hydrodynamic couplings are protected against damage due to high operation temperature by a fusible plug. The mechanical thermal switch off device has a lower reaction temperature than a fusible plug and avoids in the case of thermal overload the loss of the operation liquid by delivering a mechanical signal. By using the signal the drive system can be switched off.

### Electronical thermal switch off device

Hydrodynamic couplings are protected against damage due to high operation temperature by a fusible plug. The electronical thermal switch off device has a lower reaction temperature than a fusible plug and avoids in the case of thermal overload the loss of the operation liquid by delivering a signal. The signal will be picked up touchless from a sensor, transferred to an analysis unit and converted into a signal for switching off the drive system.

### Replacement for the fusible plug

The delivery of replacements for the fusible plug, also for different reaction temperatures, is possible on request.

### Nozzle Sets

Hydrodynamic couplings beginning with nominal size 560 will be delivered with an exchangeable standard nozzle set. By using of adapted nozzles the start up characteristic of the coupling can be adjusted to the application within a special range.

These nozzles are available on request.

### Oil filling

According to standard hydrodynamic couplings will be delivered without oil filling. The oil filling can be delivered separately in usual package units.

## Type List

### HR-C

Type HR-C hydrodynamic coupling with delay chamber

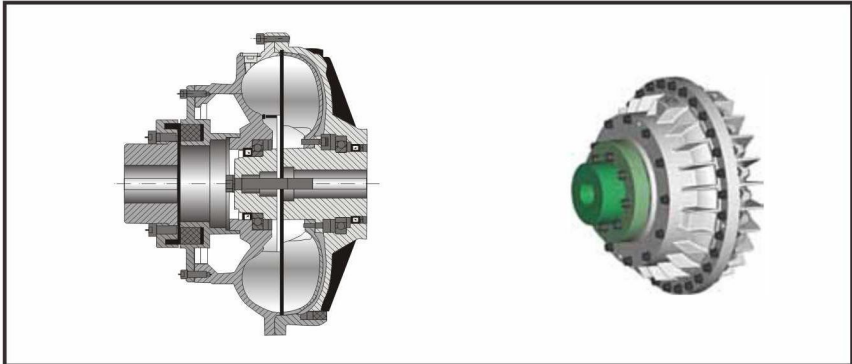

### HR-C-MRR

Type HR-C hydrodynamic coupling with delay chamber  
Type MRR coupling body removable radially without moving the drive and driven unit

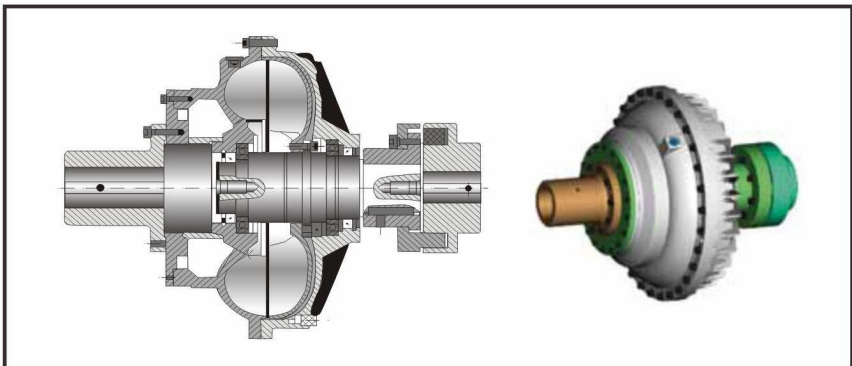

### HR-C-MBW

Type HR-C hydrodynamic coupling with delay chamber  
Type MBW the motor end bears the weight without flexible connecting coupling

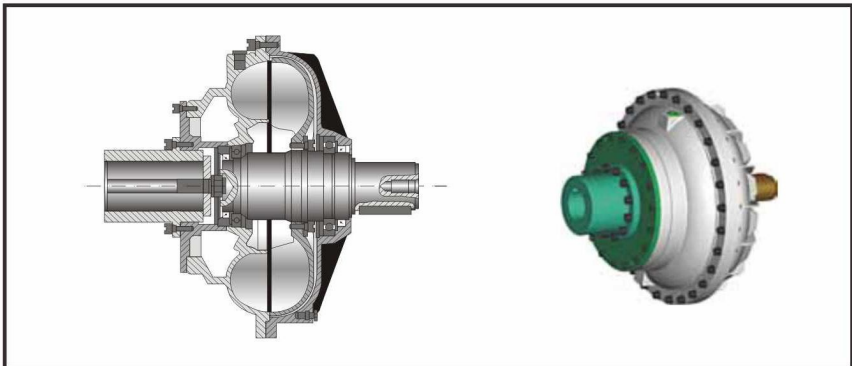

### HR-C-MB

Type HR-C hydrodynamic coupling with delay chamber  
Type MB The motor end bears the weight with flexible connecting coupling

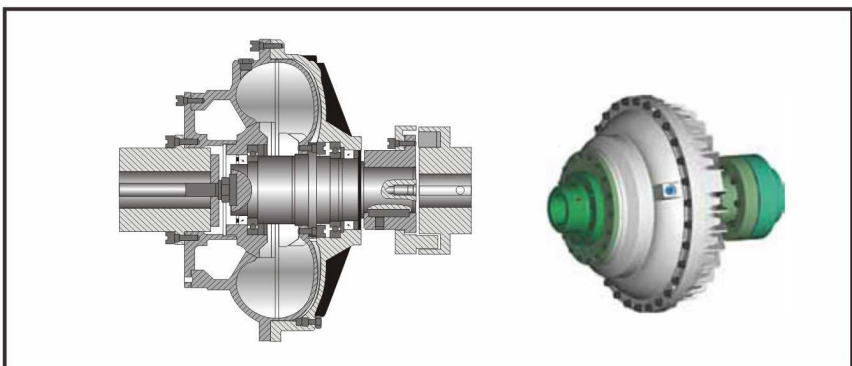

## Type List

### HR-MRR

Type HR hydrodynamic coupling without delay chamber  
 Type MRR coupling body removable radially without moving the drive and driven unit

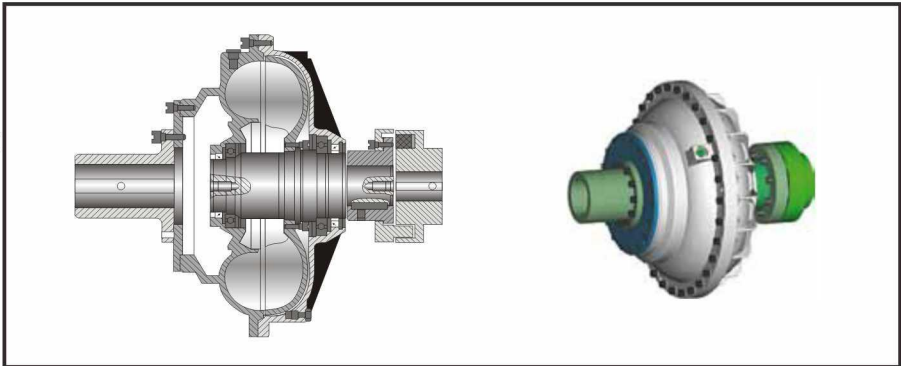

### HR-MB

Type HR hydrodynamic coupling without delay chamber  
 Type MB The motor end bears the weight

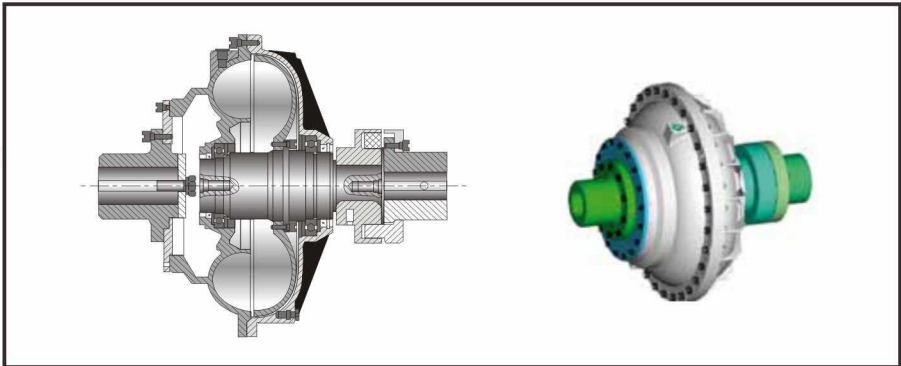

### HR-CC

Type HR-CC hydrodynamic coupling with an extended delay chamber

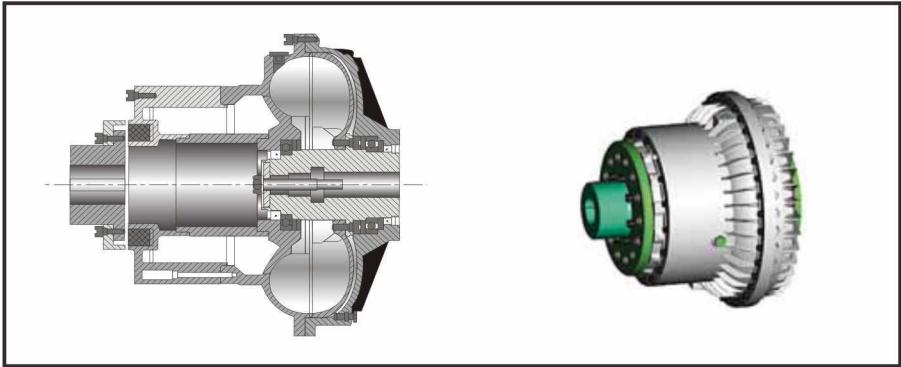

### HR-CC-MRR

Type HR-CC hydrodynamic coupling with an extended delay chamber  
 Type MRR coupling body removable radially without moving the drive and driven unit

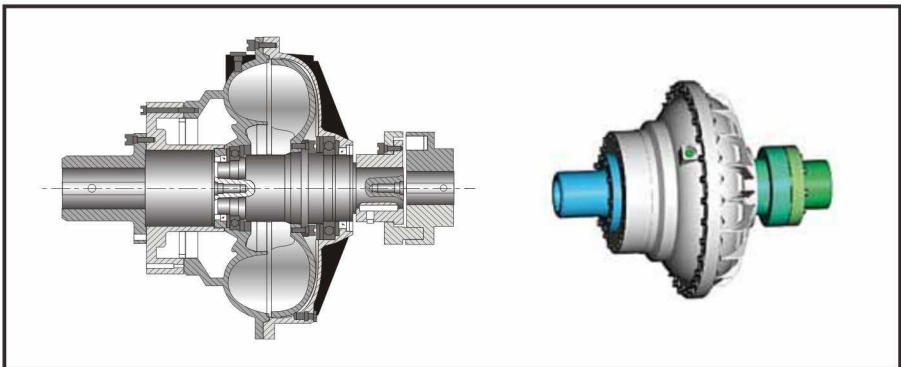



## Type List

### HR-CC-MRW

Type HR-CC hydrodynamic coupling with an extended delay chamber  
 Type MRW coupling body removable radially without moving the drive and driven unit and flexible connecting coupling

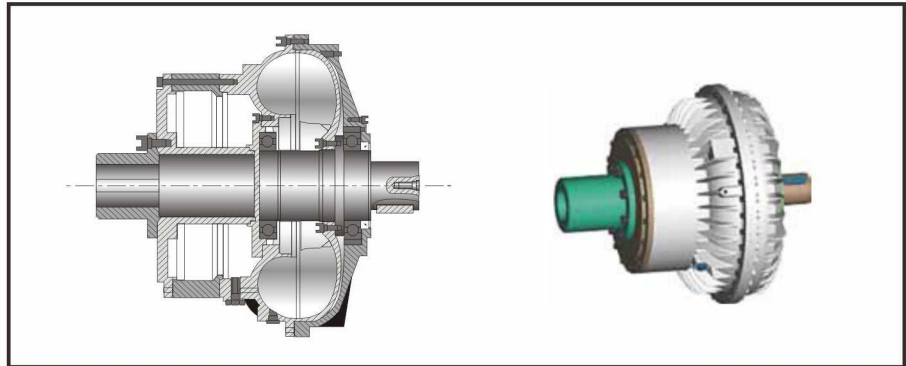

### HR-CCZ

Type HR-CCZ hydrodynamic coupling with an enlarged delay chamber and additional chamber

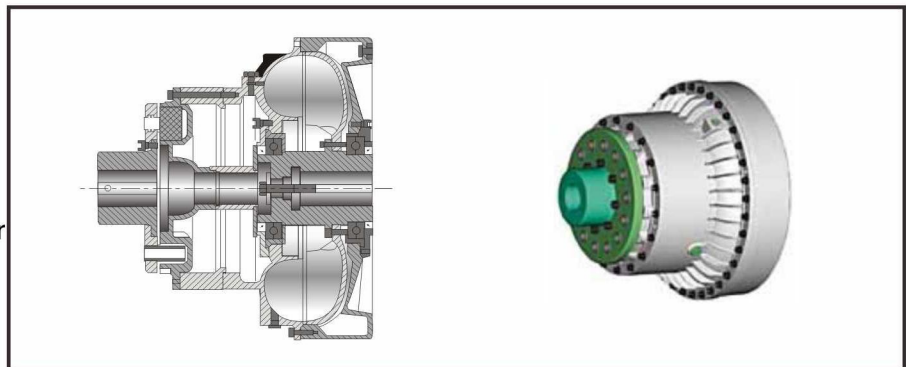

### HR-CB

Type HR-CB hydrodynamic coupling with delay chamber and brake drum

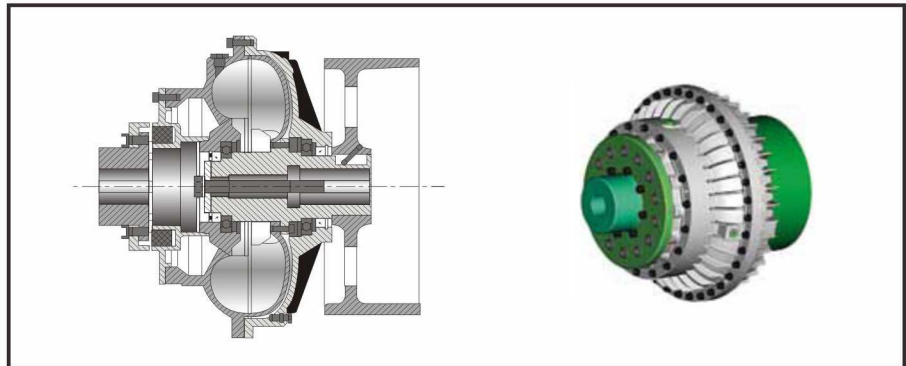

### HR-B-MRR

Type HR-B hydrodynamic coupling without delay chamber, with brake drum  
 Type MRR coupling body removable radially without moving the drive and driven unit

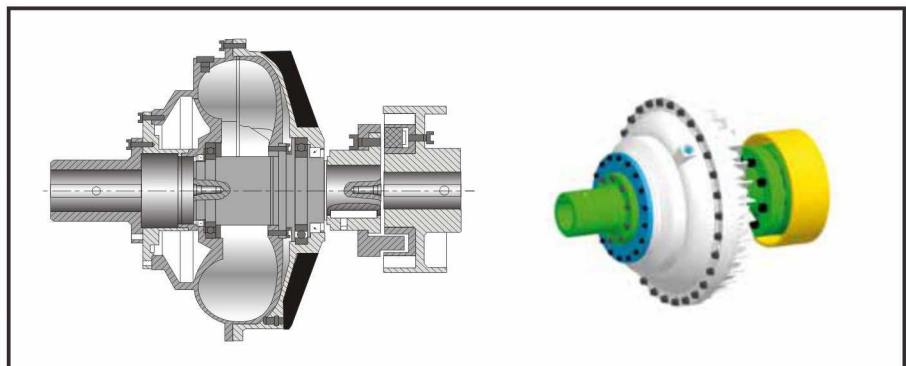

## Type List

### HR-CB-MB

Type HR-CB hydrodynamic coupling with delay chamber and brake drum

Type MB The motor end bears the weight

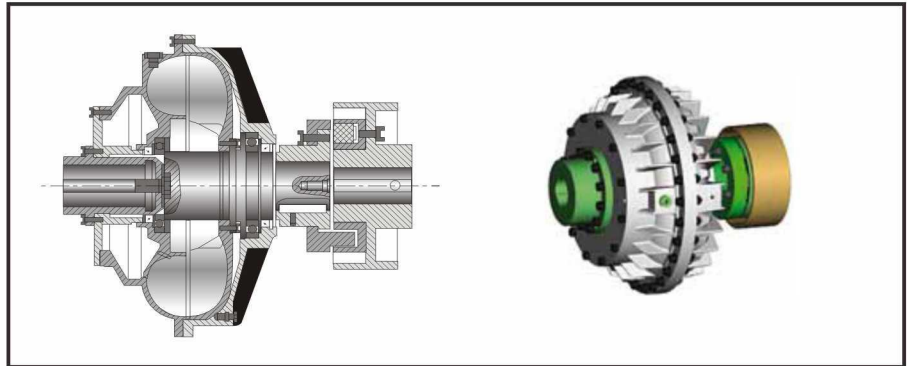

### HR-CCB-MB

Type HR-CCB hydrodynamic coupling with an extended delay chamber and brake drum

Type MB The motor end bears the weight

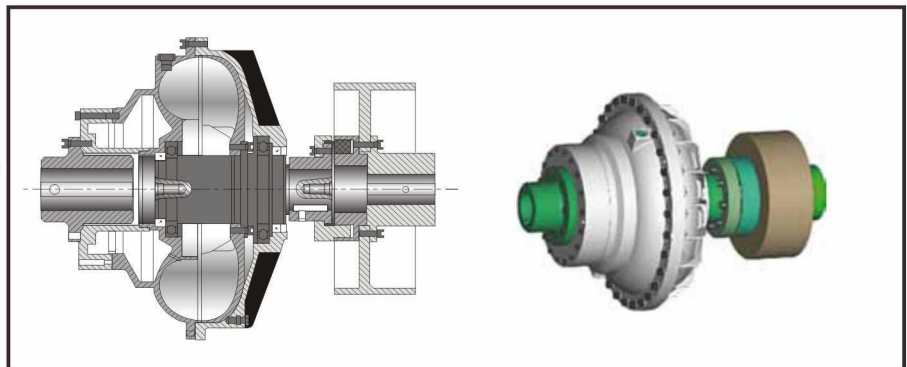

### HR-CCB-MRR

Type HR-CCB hydrodynamic coupling with an extended delay chamber and brake drum

Type MRR coupling body removable radially without moving the drive and driven unit

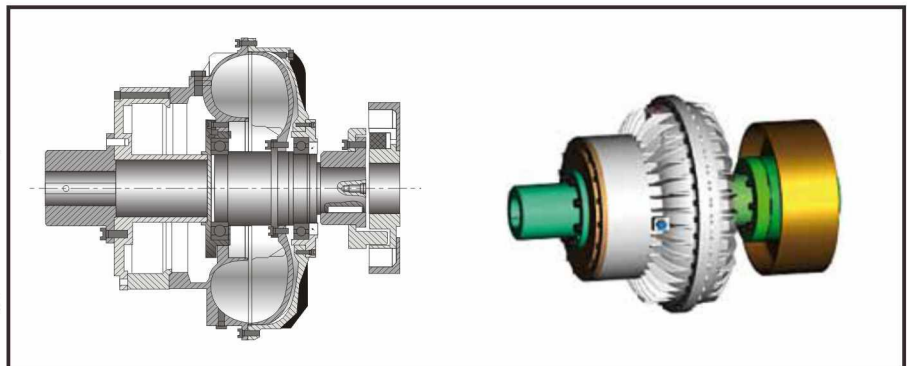

### HR-B-MB

Type HR-B hydrodynamic coupling without delay chamber with brake drum

Type MB The motor end bears the weight

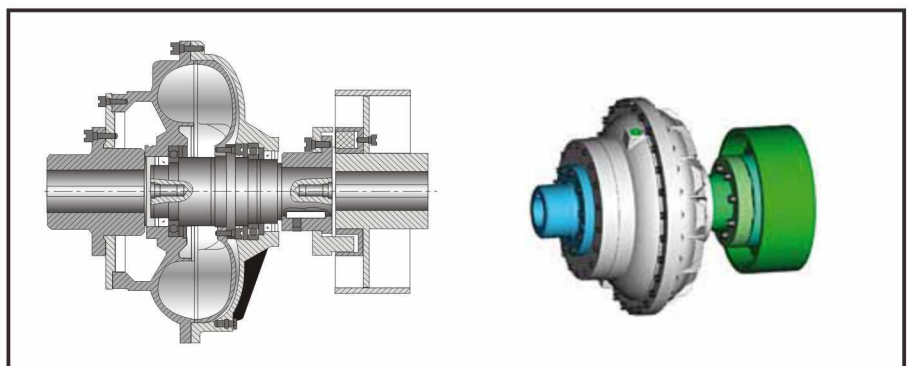

## Type List

### HR-B-MRR

Type HR-B hydrodynamic coupling without delay chamber, with brake drum  
 Type MRR coupling body removable radially without moving the drive and driven unit

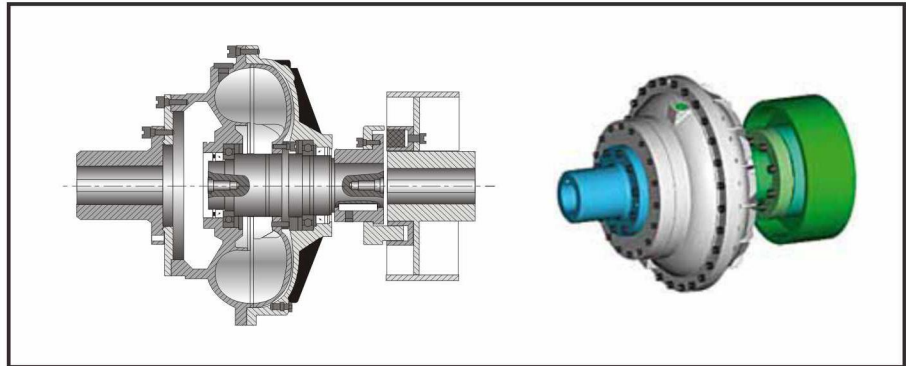

### HR-CS

Type HR-CS hydrodynamic coupling with delay chamber and brake disk

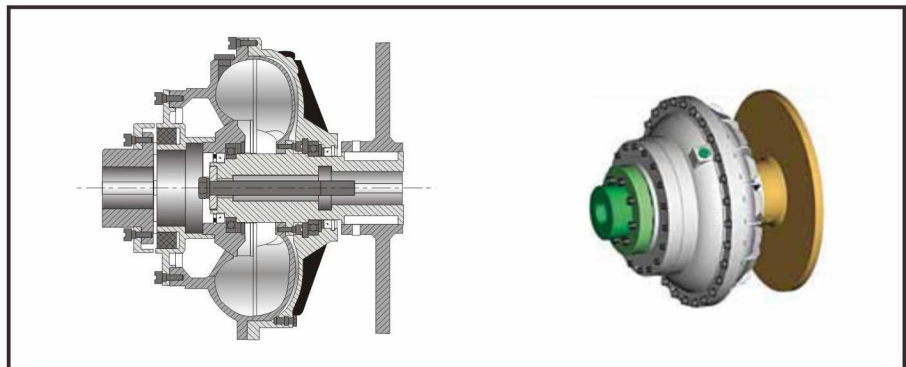

### HR-CS-MB

Type HR-CS hydrodynamic coupling with delay chamber and brake disk  
 Type MB The motor end bears the weight

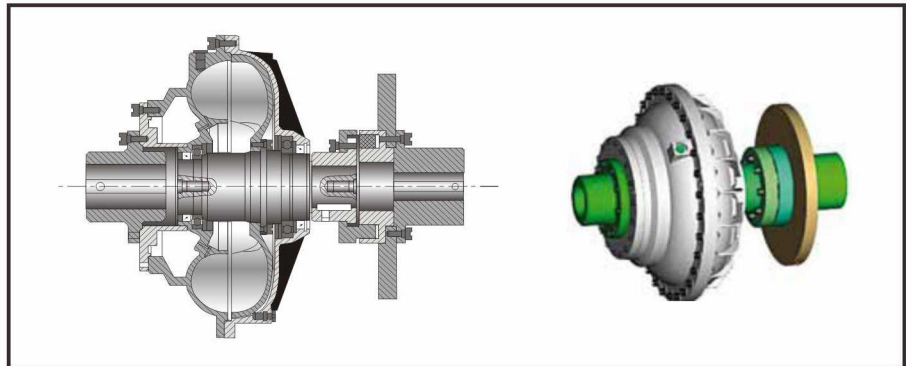

### HR-CS-MRR

Type HR-CS hydrodynamic coupling with delay chamber and brake disk  
 Type MRR coupling body removable radially without moving the drive and driven unit

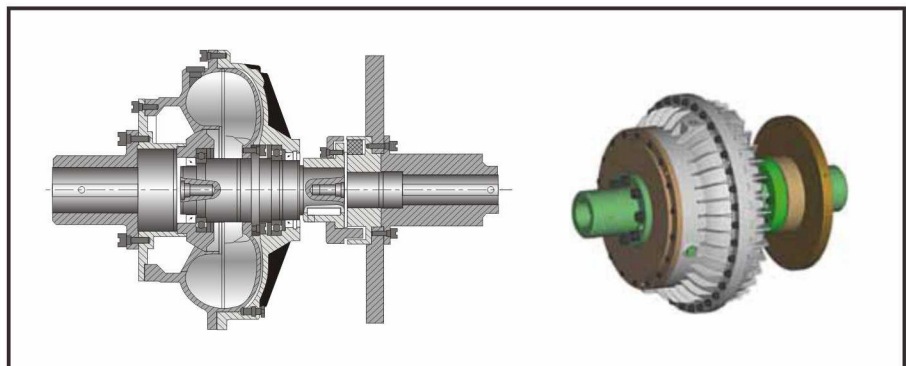



# Type List

## HR-CCS

Type HR-CCS hydrodynamic coupling with an extended delay chamber and brake disk

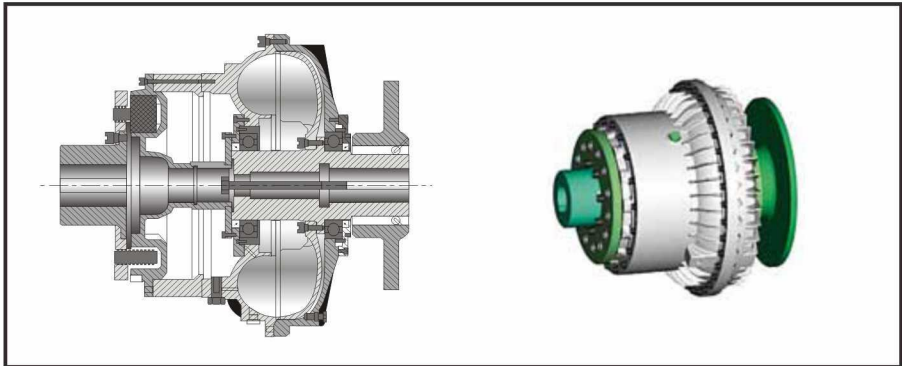

## HR-CCS-MB

Type HR-CCS hydrodynamic coupling with an extended delay chamber and brake disk  
Type MB The motor end bears the weight

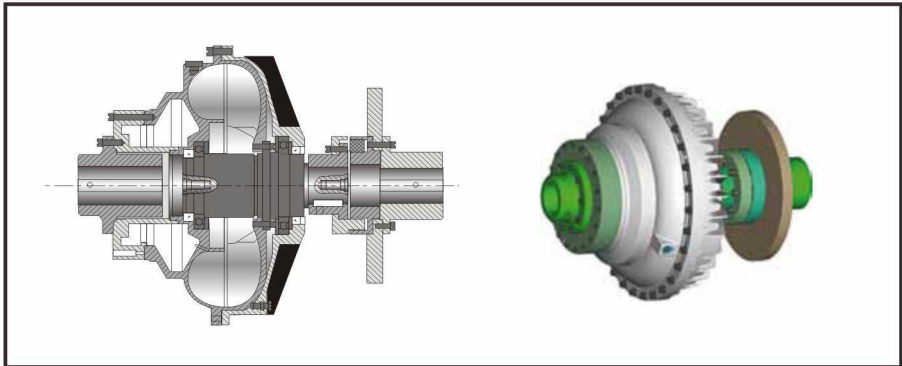

## HR-CCS-MRR

Type HR-CCS hydrodynamic coupling with an extended delay chamber and brake disk  
Type MRR coupling body removable radially without moving the drive and driven unit

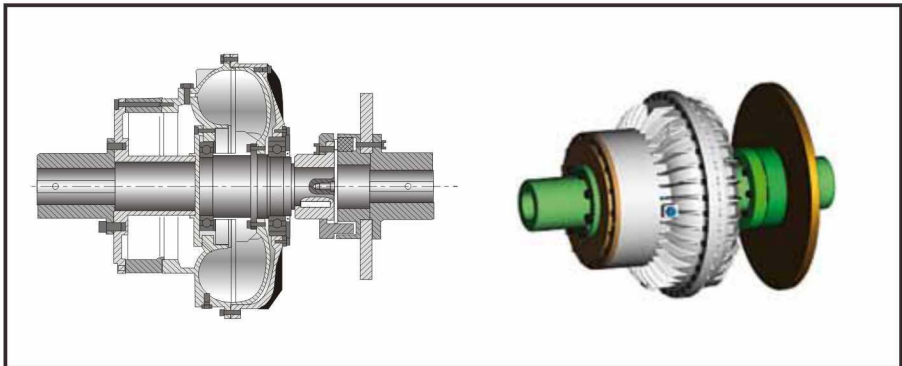

## HR-CD

Type HR-CD hydrodynamic coupling with two hydrodynamic units and a delay chamber

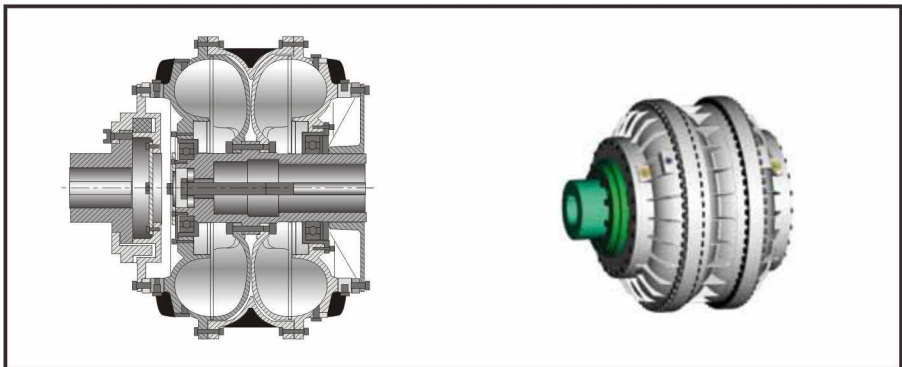

# Type List

**HR-D**  
 Type HR-D hydrodynamic coupling  
 with two hydrodynamic units

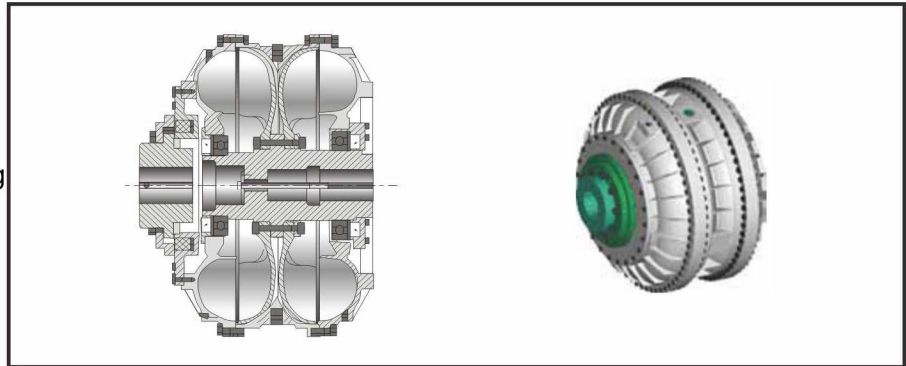

**HR-CCS-AMC-ve**  
 Type HR-CCS hydrodynamic coupling  
 with an extended delay chamber and  
 brake disk  
 Type AMC hydrodynamic coupling with  
 all-metal clutch  
 Type ve hydrodynamic coupling with  
 special design external damping sets

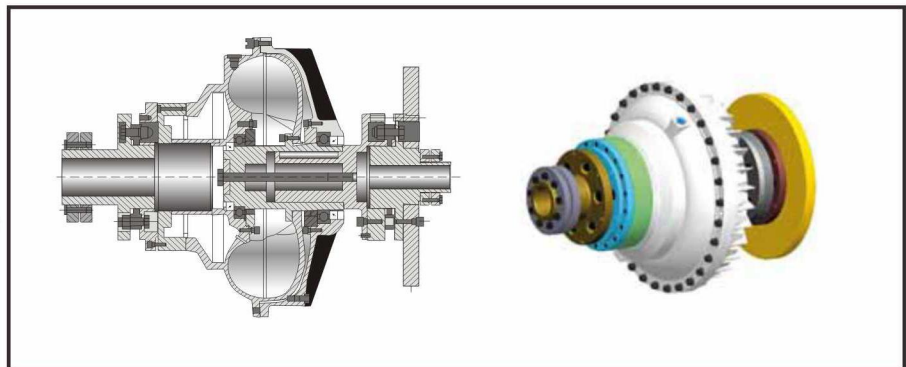

**HR-CCZ-MBW-V**  
 Type HR-CCZ hydrodynamic coupling  
 with an extend delay chamber and  
 brake disk  
 Type MBW the motor end bears the  
 weight without flexible connecting  
 coupling  
 Type v hydrodynamic coupling with  
 special design

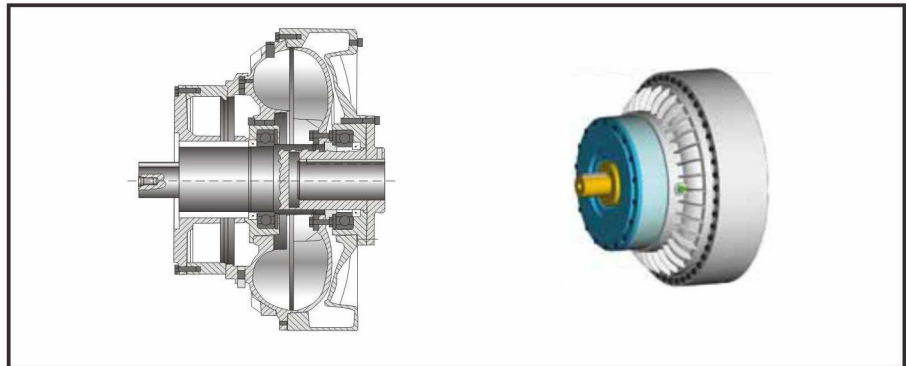

**HR-CP-r**  
 Type HR-CP hydrodynamic coupling  
 with delay chamber and pulley  
 Type r Replaceable pulley

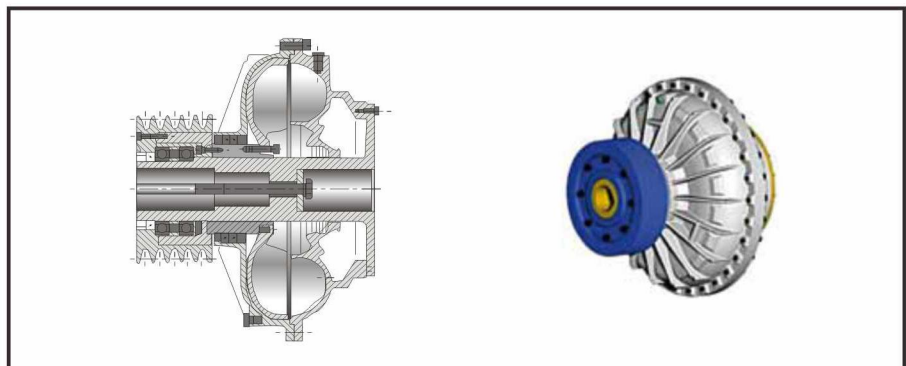

# Type List

## HR-CCZ-AMC

Type HR-CCZ hydrodynamic coupling with an enlarged delay chamber and additional chamber  
 Type AMC hydrodynamic coupling with all-metal clutch

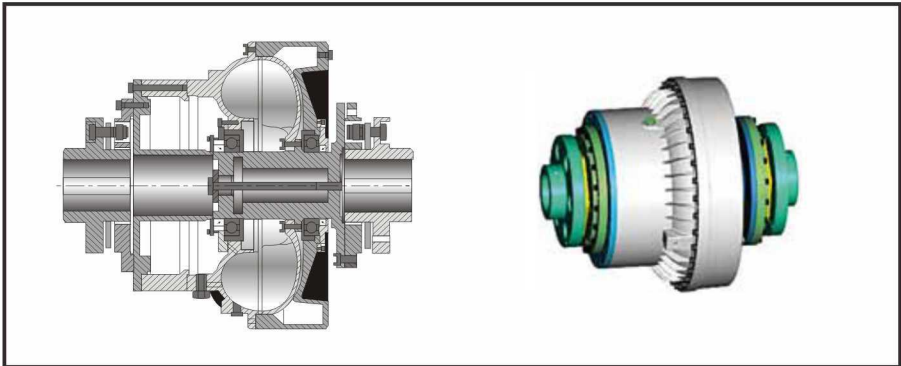

## HR-CP-id

Type HR-CP hydrodynamic coupling with delay chamber and pulley  
 Type id Internal drive

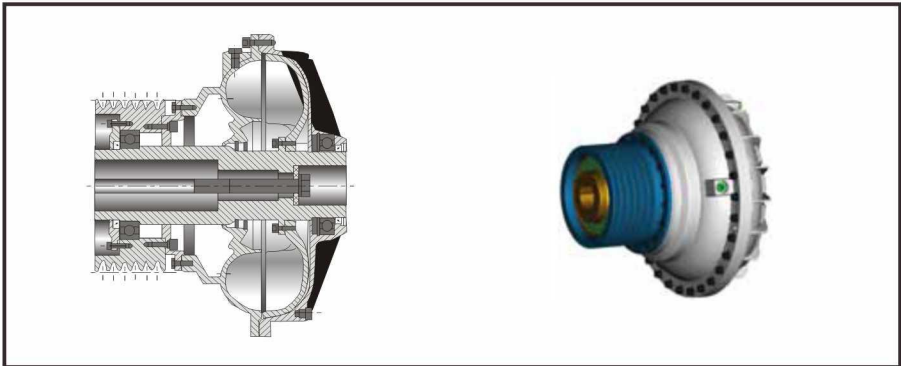

## HR-CP

Type HR-CP hydrodynamic coupling with delay chamber and pulley

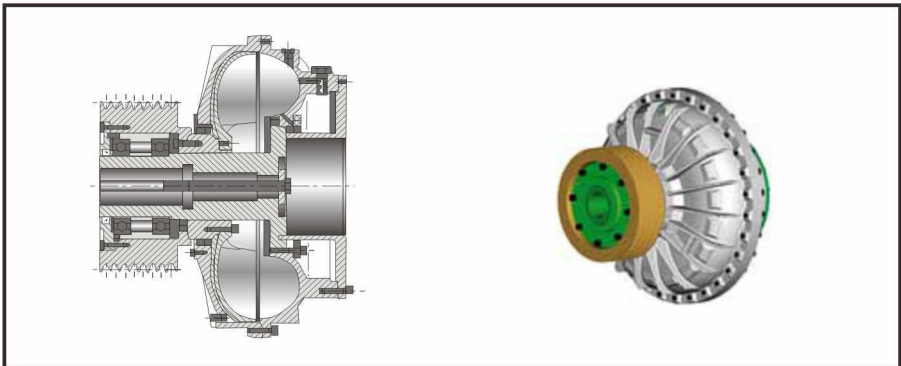

## HR-CP-vin

Type HR-CP hydrodynamic coupling with delay chamber and pulley  
 Type vin Vertical Installation

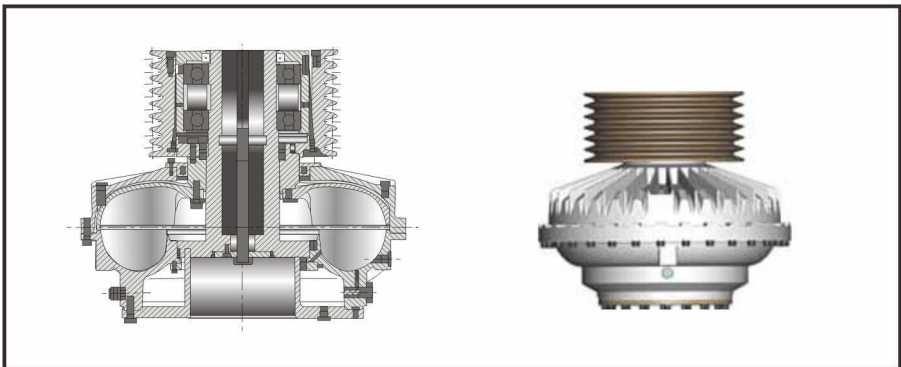



# Type List

## HR-MB-v

Type HR hydrodynamic coupling without delay chamber  
 Type v hydrodynamic coupling with special design

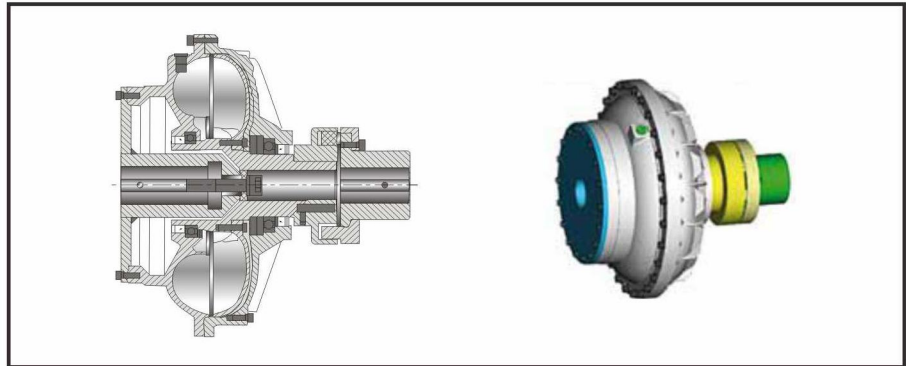

## HR-CC-DF-v

Type HR-CC hydrodynamic coupling with an extended delay chamber  
 Type DF hydrodynamic coupling with drive shaft flange  
 Type v hydrodynamic coupling with special design

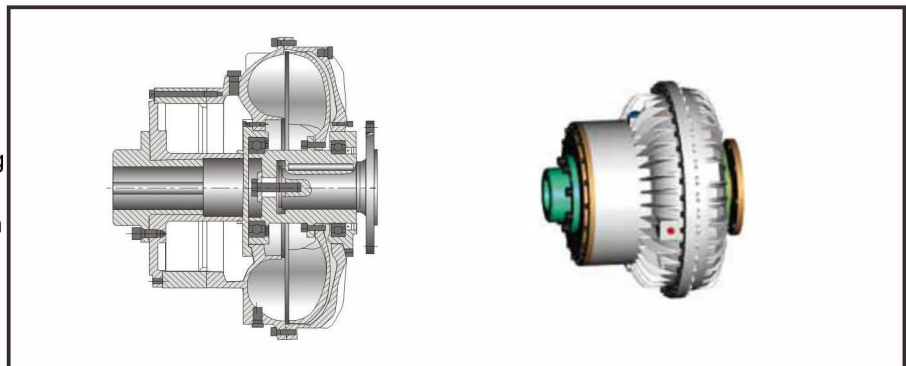

## HR-ded-v

Type HR hydrodynamic coupling without delay chamber  
 Type ded Diesel engine drive  
 Type v hydrodynamic coupling with special design

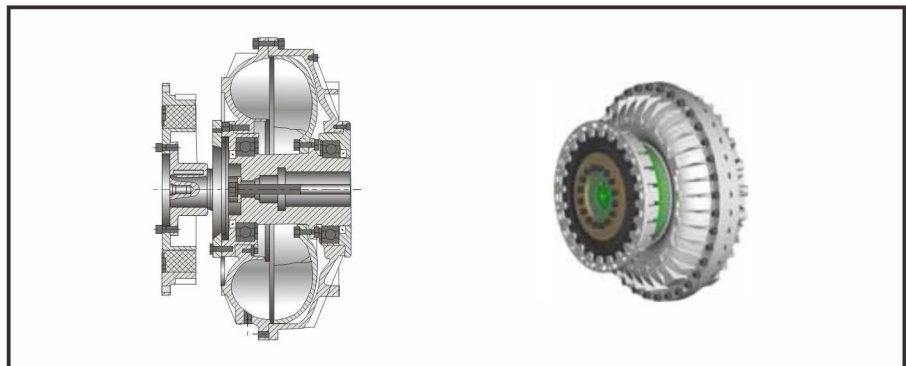

## HR-dedh-v

Type HR hydrodynamic coupling without delay chamber  
 Type dedh Diesel engine drive and housing  
 Type v hydrodynamic coupling with special design

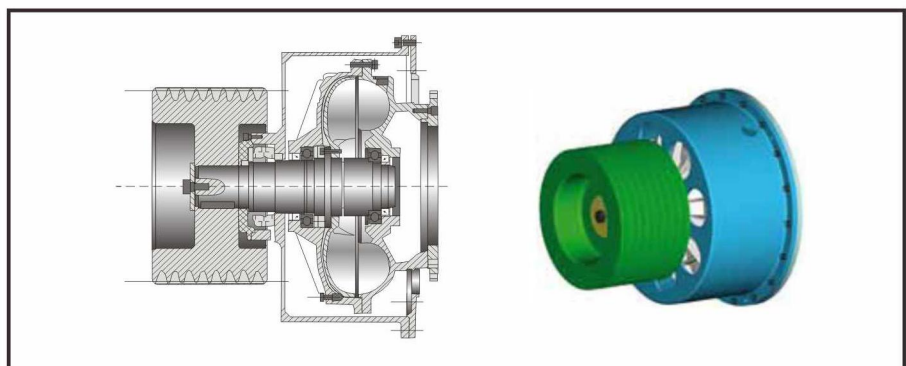



库威得  
KUDOSWORLD



**SHENYANG KUDOSWORLD TECHNOLOGY CO., LTD**

Add: Orchard Summer Palace, No.209-2 Qingnian Street, Shenhe

District, Shenyang City, China 110016

Tel: 0086 (024) 31976438

Fax: 0086(024) 3197 6437