

DATA SHEET



Three Phase Induction Motor - Squirrel Cage

Customer : SC Watt Drive Motor SRL

Product line : W22 IE3 Three-Phase Product code : 12863260

Frame	: 355M/L	Locked rotor time	: 100s (cold) 56s (hot)
Output	: 200 kW (270 HP)	Temperature rise	: 80 K
Poles	: 8	Duty cycle	: S1
Frequency	: 50 Hz	Ambient temperature	: -20°C to +40°C
Rated voltage	: 400/690 V	Altitude	: 1000 m.a.s.l.
Rated current	: 381/221 A	Protection degree	: IP55
L. R. Amperes	: 2362/1369 A	Cooling method	: IC411 - TEFC
LRC	: 6.2	Mounting	: B3T
No load current	: 170/98.6 A	Rotation ¹	: Both (CW and CCW)
Rated speed	: 745 rpm	Noise level ²	: 70.0 dB(A)
Slip	: 0.67 %	Starting method	: Direct On Line
Rated torque	: 2570 Nm	Approx. weight ³	: 1997 kg
Locked rotor torque	: 130 %		
Breakdown torque	: 229 %		
Insulation class	: F		
Service factor	: 1.00		
Moment of inertia (J)	: 18.9 kgm ²		
Design	: N		

Output	50%	75%	100%	Foundation loads	
Efficiency (%)	94.3	94.8	94.8	Max. traction	: 28007 N
Power Factor	0.65	0.76	0.80	Max. compression	: 47598 N

	<u>Drive end</u>	<u>Non drive end</u>
Bearing type	: 6322 C3	6319 C3
Sealing	: WSeal	WSeal
Lubrication interval	: 19000 h	20000 h
Lubricant amount	: 60 g	45 g
Lubricant type	: Mobil Polyrex EM	

Notes

This revision replaces and cancel the previous one, which must be eliminated.

- (1) Looking the motor from the shaft end.
- (2) Measured at 1m and with tolerance of +3dB(A).
- (3) Approximate weight subject to changes after manufacturing process.
- (4) At 100% of full load.

These are average values based on tests with sinusoidal power supply, subject to the tolerances stipulated in IEC 60034-1.

Rev.	Changes Summary	Performed	Checked	Date
Performed by				
Checked by			Page	Revision
Date	16/03/2021		1 / 6	

DATA SHEET



Three Phase Induction Motor - Squirrel Cage

Customer : SC Watt Drive Motor SRL

Thermal protection

ID	Application	Type	Quantity	Sensing Temperature
1	Winding	Thermistor - 2 wires	1 x Phase	155 °C

Rev.	Changes Summary	Performed	Checked	Date
Performed by				
Checked by			Page	Revision
Date	16/03/2021		2 / 6	

TORQUE AND CURRENT VS SPEED CURVE

Three Phase Induction Motor - Squirrel Cage



Customer : SC Watt Drive Motor SRL

Product line : W22 IE3 Three-Phase

Product code : 12863260

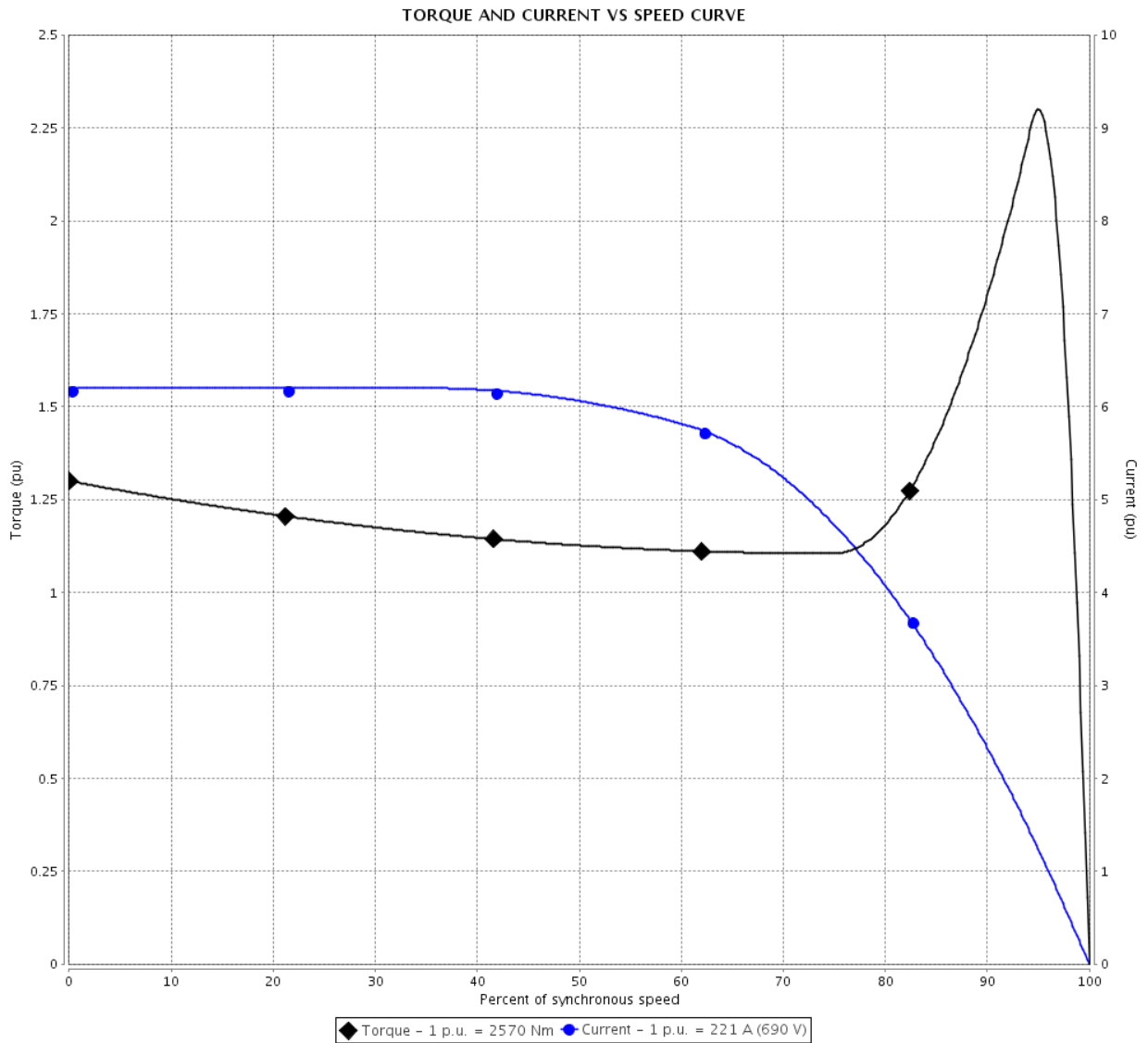

Performance : 400/690 V 50 Hz 8P

Rated current	: 381/221 A	Moment of inertia (J)	: 18.9 kgm ²
LRC	: 6.2	Duty cycle	: S1
Rated torque	: 2570 Nm	Insulation class	: F
Locked rotor torque	: 130 %	Service factor	: 1.00
Breakdown torque	: 229 %	Temperature rise	: 80 K
Rated speed	: 745 rpm	Design	: N

Locked rotor time : 100s (cold) 56s (hot)

Rev.	Changes Summary	Performed	Checked	Date
Performed by			Page 3 / 6	Revision
Checked by				
Date	16/03/2021			

LOAD PERFORMANCE CURVE

Three Phase Induction Motor - Squirrel Cage



Customer : SC Watt Drive Motor SRL

Product line : W22 IE3 Three-Phase

Product code : 12863260

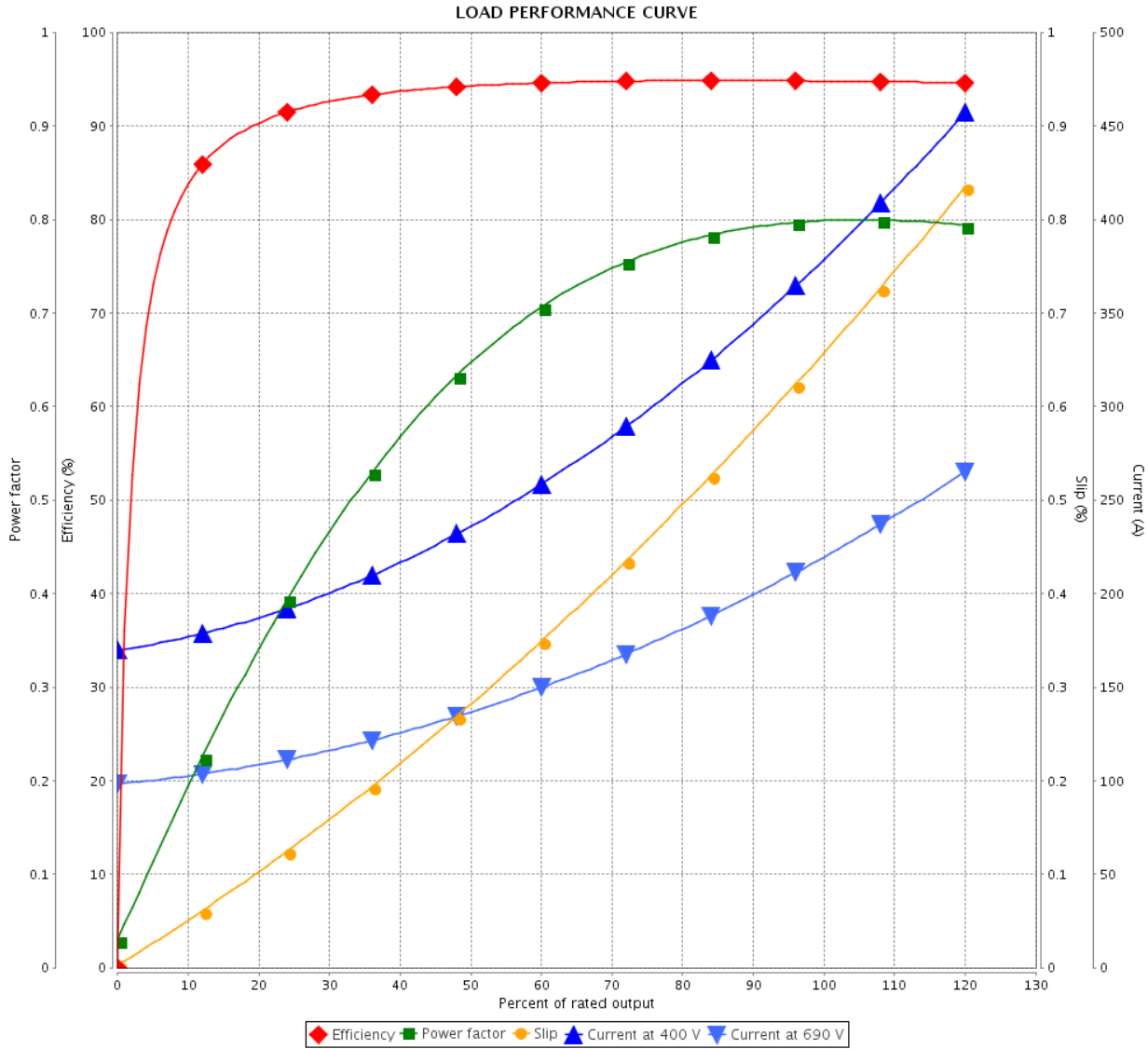

Performance : 400/690 V 50 Hz 8P

Rated current : 381/221 A
 LRC : 6.2
 Rated torque : 2570 Nm
 Locked rotor torque : 130 %
 Breakdown torque : 229 %
 Rated speed : 745 rpm

Moment of inertia (J) : 18.9 kgm²
 Duty cycle : S1
 Insulation class : F
 Service factor : 1.00
 Temperature rise : 80 K
 Design : N

Rev.	Changes Summary	Performed	Checked	Date
Performed by		Page		Revision
Checked by		4 / 6		
Date		16/03/2021		

THERMAL LIMIT CURVE

Three Phase Induction Motor - Squirrel Cage



Customer : SC Watt Drive Motor SRL

Product line : W22 IE3 Three-Phase

Product code : 12863260

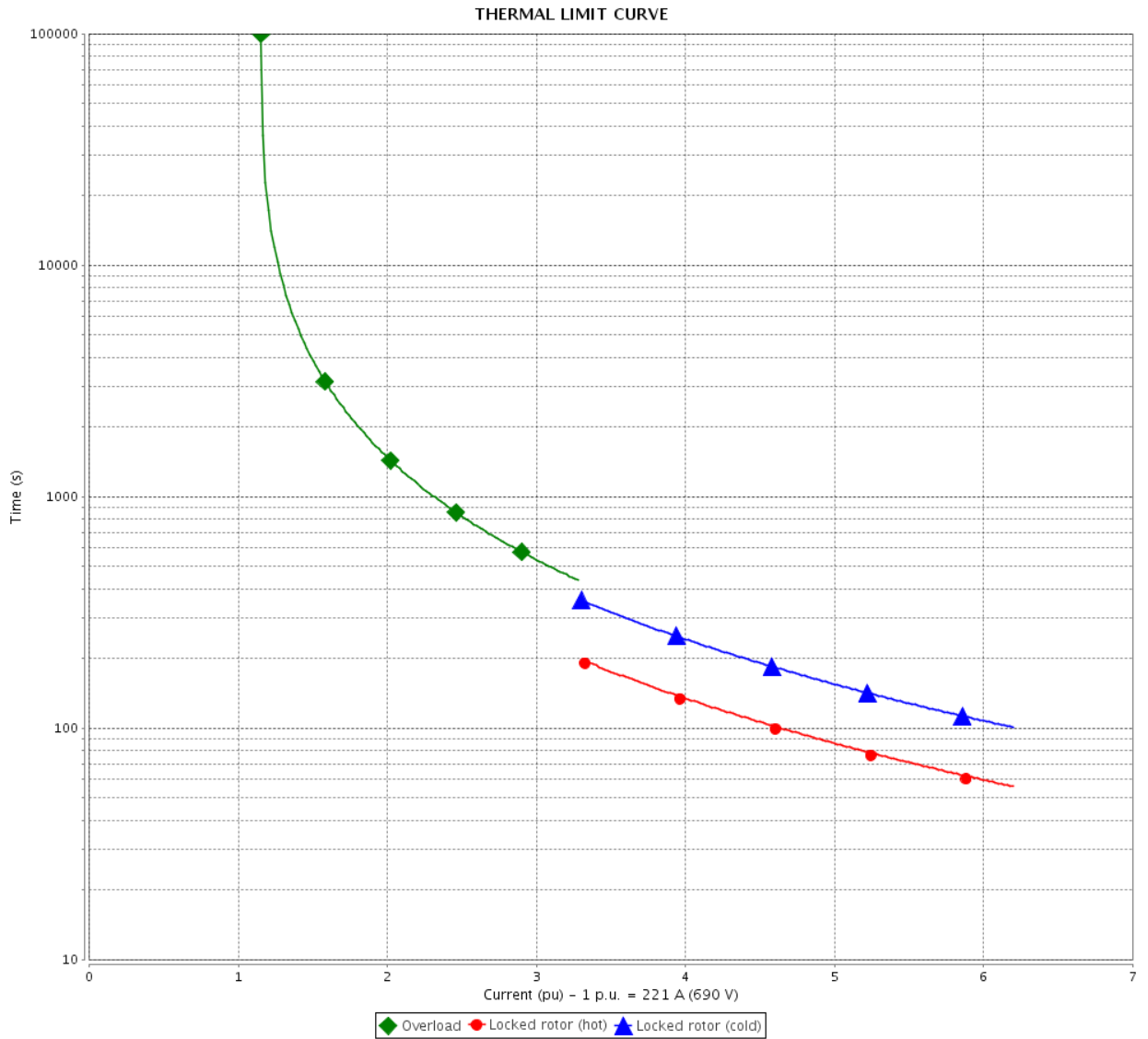

Performance : 400/690 V 50 Hz 8P

Rated current : 381/221 A
 LRC : 6.2
 Rated torque : 2570 Nm
 Locked rotor torque : 130 %
 Breakdown torque : 229 %
 Rated speed : 745 rpm

Moment of inertia (J) : 18.9 kgm²
 Duty cycle : S1
 Insulation class : F
 Service factor : 1.00
 Temperature rise : 80 K
 Design : N

Heating constant

Cooling constant

Rev.	Changes Summary	Performed	Checked	Date
Performed by				
Checked by				
Date				
		Page	Revision	
		5 / 6		

VFD OPERATION CURVE

Three Phase Induction Motor - Squirrel Cage



Customer : SC Watt Drive Motor SRL

Product line : W22 IE3 Three-Phase

Product code : 12863260

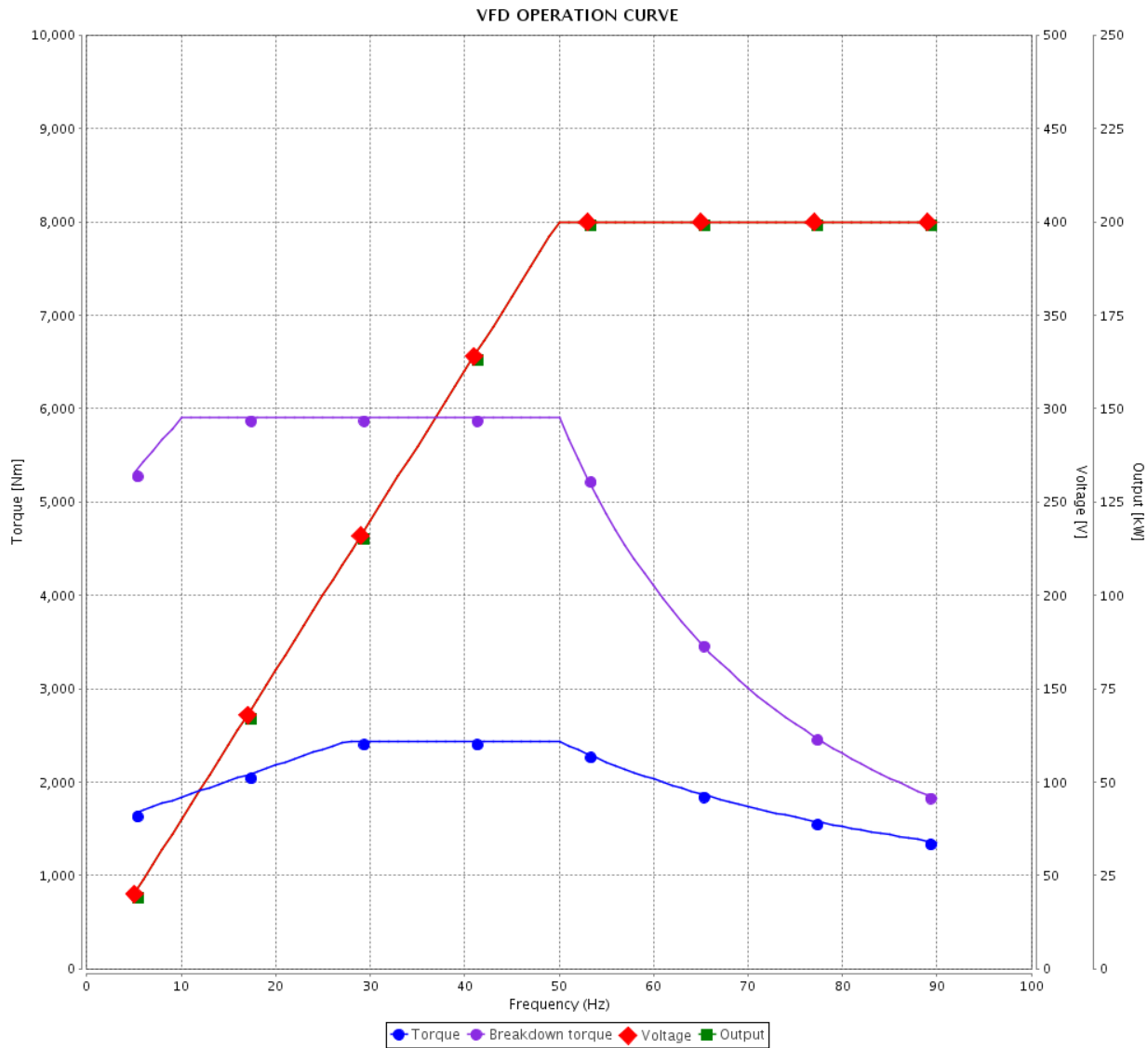

Performance : 400/690 V 50 Hz 8P

Rated current : 381/221 A
 LRC : 6.2
 Rated torque : 2570 Nm
 Locked rotor torque : 130 %
 Breakdown torque : 229 %
 Rated speed : 745 rpm

Moment of inertia (J) : 18.9 kgm²
 Duty cycle : S1
 Insulation class : F
 Service factor : 1.00
 Temperature rise : 80 K
 Design : N

Rev.	Changes Summary	Performed	Checked	Date
Performed by			Page 6 / 6	Revision
Checked by				
Date	16/03/2021			

1 2 3 4 5 6

A

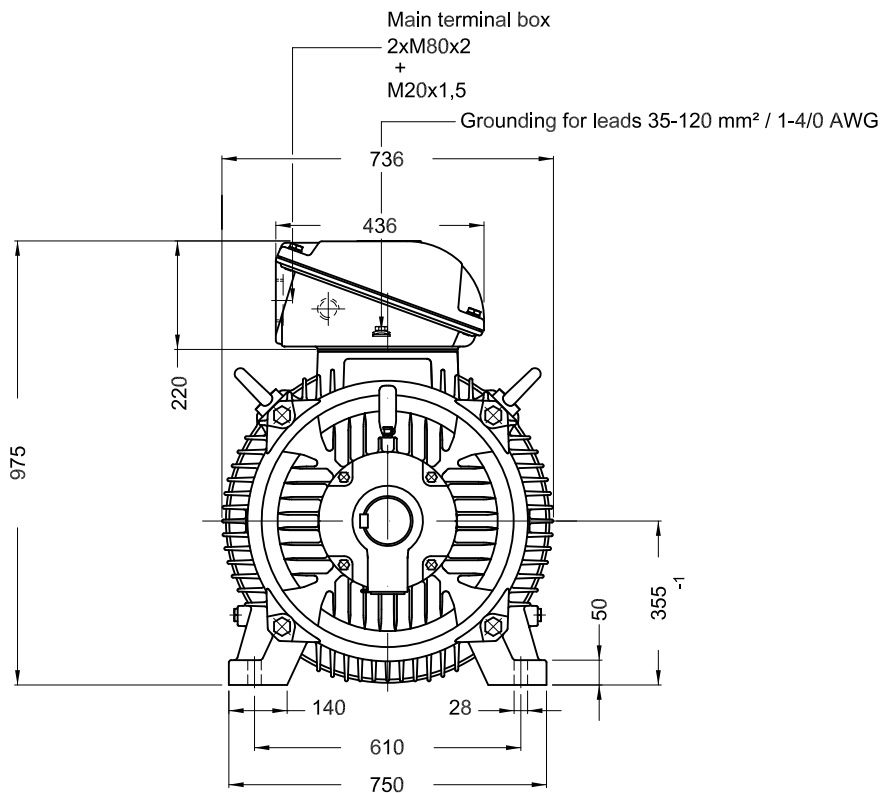

B

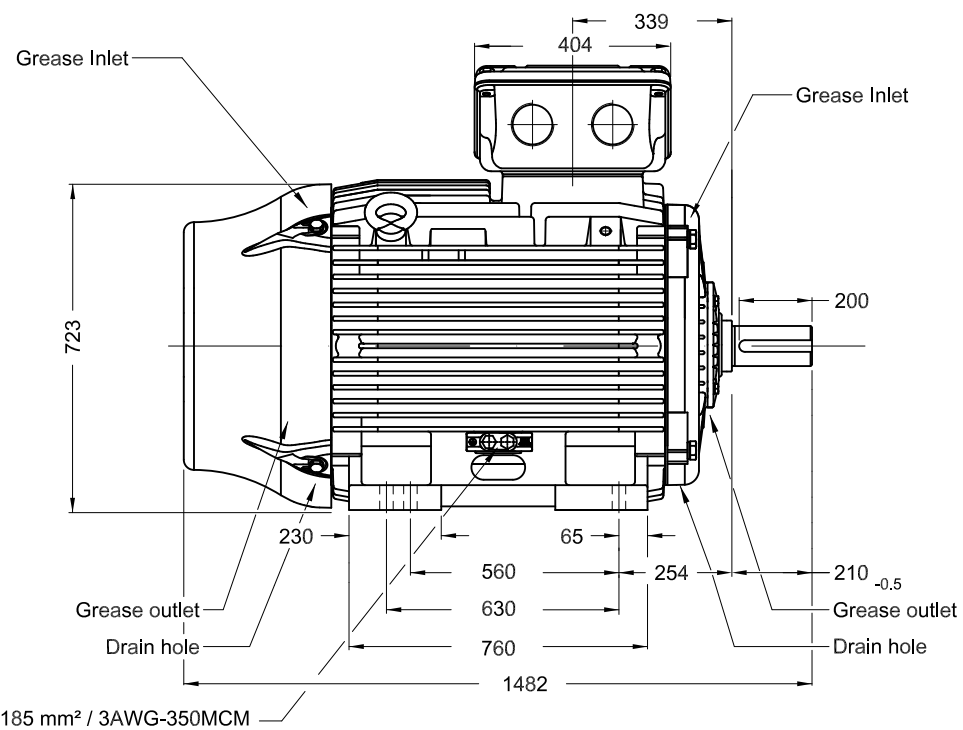

C

D

E

Without vertical jackscrews
NDE endshield with electrically insulated bearing hub
Color RAL 5009
Painting plan 203A
Mounting B3T

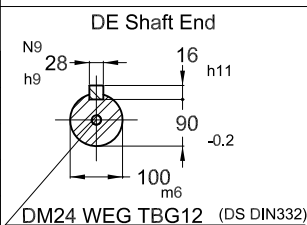

200 kW 08 Poles 50 Hz A

ECM	LOC	SUMMARY OF MODIFICATIONS	EXECUTED	CHECKED	RELEASED	DATE	VER
EXECUTED	PIRWBUSER	THREE PHASE W22 MOTOR - PREMIUM EFF					
CHECKED		FRAME 355M/L IP55 TEFC					
RELEASED							
REL DT.	WMO	Jaragua do Sul	Product Engineering	SHEET	1 / 1		

PREVIEW
WDD

