



## OPERATING INSTRUCTION FOR BAND SAW

# PMS 170/210 MO



Before transporting and using the machine, please read the instructions thoroughly!



Serial No.:

### Specifications

Cutting capacity	●	■	—			Floor Space	
90°	170 mm	170x170 mm	210x95 mm	Blade size	20x0,9x2110 mm	L x W x H	1500x800x1620 mm
45°	120 mm	110x110 mm		Blade speed	40/80 m/min (50 Hz)	Net Weight	156 kg
60°	70 mm	65x65 mm		Motor	0,75 kW	Gross weight	170 kg

# Contents

## Chapter 1

### ACCIDENT PREVENTION AND SAFETY REGULATION

1.1 Advice for the Operator .....	2
1.2 The Electrical Equipment According to European Standard" CENELEC EN 60 204-1" (1992).....	2
1.3 Emergencies According to European Standard "CENELEC EN 60 204-1 (1992)" .....	2

## Chapter 2

### MACHINE DIMENSIONS TRANSPORT INSTALLATION DISMANTLING

2.1 Machine Dimensions .....	2
2.2 Transportation of Your Machine .....	3
2.3 Minimum Requirements for Housing the Machine.....	3
2.4 Anchoring the Machine .....	3
2.5 Instructions for Assembly of the Loose Parts and Accessories .....	3
2.6 Deactivation of Machine .....	3
2.7 Dismantling .....	3

## Chapter 3

### THE MACHINE'S FUNCTIONAL PARTS

3.1 The Saw Bow .....	3
3.2 Controls .....	4
3.3 Vise Adjustment .....	4
3.4 Cutting Angle Adjustment .....	4
3.5 The Base .....	4

## Chapter 4

### OPERATING AND ADVICE ON USING YOUR BANDSAW

4.1 The Operation Cycle .....	5
4.2 Recommendations for Using the Machine .....	6

## Chapter 5

### ADJUSTING YOUR MACHINE

5.1 Blade Tension Assembly .....	6
5.2 Aligning the Flywheel .....	7
5.3 Checking the Adjustment of the Blade .....	7
5.4 Adjusting the Blade Guide .....	7
5.5 Changing the Blade .....	8

## Chapter 6

### ROUTINE AND SPECIAL MAINTENANCE

6.1 Daily Maintenance .....	8
6.2 Weekly Maintenance .....	8
6.3 Monthly Maintenance .....	8
6.4 Six-monthly Maintenance .....	8
6.5 Oils for Lubricating Coolant .....	8
6.6 Oil Disposal .....	8
6.7 Coolant System .....	8
6.8 The Gearbox .....	9
6.9 Special Maintenance .....	9

## Chapter 7

### TECHNICAL CHARACTERISTICS

7.1 Table of Cutting Capacity and Technical Details ..	9
--	---

## Chapter 8

### MATERIAL CLASSIFICATION AND CHOICE OF TOOL

8.1 Definition of Materials .....	10
8.2 Selecting Blade .....	10
8.3 Teeth Pitch .....	10
8.4 Cutting and Advance Speed .....	10
8.5 Blade Running-in .....	10
8.6 Blade Structure .....	10
8.7 Blade Type .....	10

## Chapter 9

### NOISE TESTS

.....	11
-------	----

## Chapter 10

### WIRING DIAGRAM

.....	12
-------	----

## Chapter 11

### TROUBLESHOOTING

11.1 - Electrical Components Diagnosis .....	14
11.2 - Blade and Cut Diagnosis .....	16

## Chapter 12

### MACHINE COMPONENTS

12.1 Parts List .....	20
12.2 Explosion Drawings .....	22

# 1 ACCIDENT PREVENTION AND SAFETY REGULATION

This machine has been designed to comply with national and community accident-prevention regulations. Improper use and/or tampering with the safety devices will relieve the manufacturer of all responsibility.

## 1.1 Advice for the Operator

- Check that the voltage indicated on machine motor is the same as the line voltage.
- Check the efficiency of your electric supply and grounding system; connect the power cable of the machine to the socket and the ground lead (yellow-green in color) to the grounding system.
- When the saw frame is in suspended mode (or raised) the blade must not move.
- Only the blade section used for cutting must be kept unprotected. To adjust the blade guards use on the blade guides.
- It is forbidden to use the machine without its shields
- Always disconnect the machine from the power socket before blade change or carrying out any maintenance job, even in the case of abnormal machine operation.
- Always wear suitable eyes protection.
- Never put your hands or arms into the cutting area while the machine is operating.
- Do not shift the machine while it is cutting.
- Do not wear loose clothing like: shirts with sleeves that are too long, gloves that are too big, bracelets, chains or any other object that could get caught in the machine during operation. Tie back long hair.
- Keep the area free of equipment, tools, or any other object.
- Perform only one operation at a time. Never have several objects in your hands at the same time. Keep your hands as clean as possible.
- All internal operations, maintenance or repairs, must be performed in a well-lit area or where there is sufficient light from extra sources so as to avoid the risk of even slight accidents

## 1.2 The electrical equipment according to European Standard "CENELEC EN 60 204-1" which assimilates, with some integrating modifications, the publication "IEC 204-1 (1992)"

- The electrical equipment ensures protection against electric shock as a result of direct or indirect contact. The active parts of this equipment are housed in a box to which access is limited by screws that can only be removed with a special tool; the parts are fed with alternating current as low voltage (24V). The equipment is protected against splashes of water and dust.
- Protection of the system against short circuits is ensured by means of rapid fuses and grounding; in the event of a motor overload, protection is provided by a thermal probe.
- In the event of a power cut, the specific start-up button must be reset.

- The machine has been tested in conformity with point 20 of EN 60204

## 1.3 Emergencies according to European Standard "CENELEC EN 60 204-1 (1992)"

- In the event of incorrect operation or of danger conditions, the machine may be stopped immediately by pressing the red mushroom button.
- The casual or voluntary removal of the protection shield of the flywheels causes the stepping-in of a micro-switch that automatically stops all machine functions.

NOTE: Resetting of machine operation after each emergency stop requires specific restart button.

# 2 MACHINE DIMENSIONS TRANSPORT INSTALLATION DISMANTLING

## 2.1 Machine Dimensions

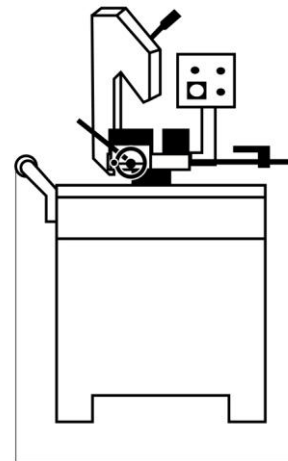

800mm

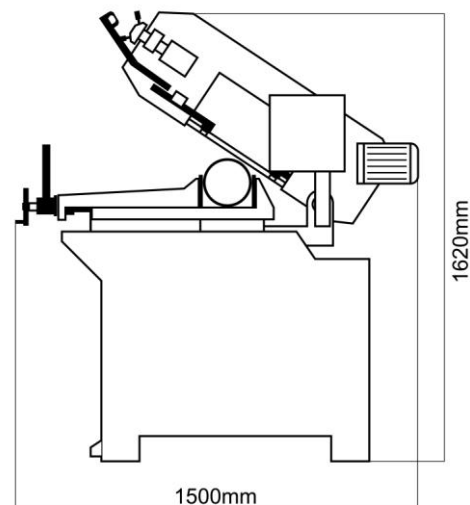

1620mm

1500mm

## 2.2 Transportation of Your Machine

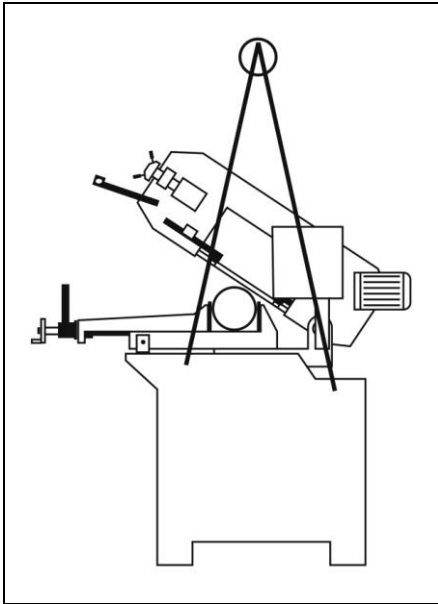

To move the machine, the machine needs to be moved in its own packing, use a forklift truck or sling it with straps as illustrated in the drawing above.

## 2.3 Minimum Requirements for Housing the Machine

- Main voltage and frequency must comply with the machine's motor requirements.
- Environment temperature should fall within  $-10\text{ }^{\circ}\text{C}$  to  $+50\text{ }^{\circ}\text{C}$ .
- Relative humidity cannot be over 90%.

## 2.4 Anchoring the Machine

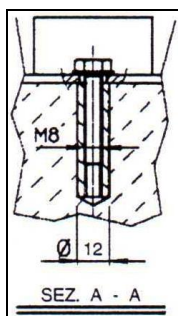

Position the machine on a firm cement floor, maintaining, at the rear, a minimum distance of 800 mm from the wall; anchor it to the ground as shown in the diagram, using screws and expansion plugs or tie rods sunk in cement, ensuring that it is sitting level.

## 2.5 Instructions for Assembly of the Loose Parts and Accessories

Fit the components supplied:

Detail 1 Mount bar-stop rod

Detail 2 Mount and align the roll-supporting arm as per the vise table.

## 2.6 Deactivation of Machine

- If the sawing machine is to be out of use for a long period, it is advisable to proceed as follows:

- 1) Detach the plug from the electric supply panel
- 2) Loosen blade
- 3) Release the saw bow's counter-balance spring
- 4) Empty the coolant tank
- 5) Carefully clean and grease the machine
- 6) If necessary, cover the machine.

## 2.7 Dismantling (due to deterioration and/or obsolescence)

### General rules

If the machine is to be permanently demolished and/or scrapped, divide the material to be disposed of according to type and composition, as follows:

- 1) Non-composite cast iron or ferrous materials are recyclable raw materials, so they may be taken to an iron foundry for re-smelting after having removed the contents (classified in point 3).
- 2) Electrical components, including the cable and electronic material (magnetic cards, etc.), fall within the category of material classified as being assimilated to urban waste according to the laws of your local, state, or federal government, so they may be set aside for collection by the public waste disposal service;
- 3) Old mineral and synthetic and/or mixed oils, emulsified oils and greases are considered hazardous or special refuse, so they must be collected, transported and disposed of at a special waste disposal service.

NOTE: The standards and legislation concerning refuse is in a constant state of evolution, therefore is subject to changes. The user must keep informed of the regulations at the time of disposal as these may differ from those described above.

## 3 THE MACHINE'S FUNCTIONAL PARTS

### 3.1 The Saw Bow

The saw bow is a collection of machine parts consisting of a saw bow, drive members (gears transfer, motor, blade wheel), blade tension system, blade guides, and blade guards. The WE-210SH model also includes a hydraulic cylinder and adjustable counter-balance spring.



### 3.2 Controls

For model PMS 170/210 MO

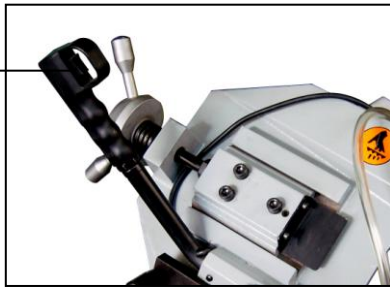

- D. Emergency Push Button
- E. ON/OFF Trigger and Control Handle
- F. Manual/Hydraulic Selector

### 3.3 Vise Adjustment

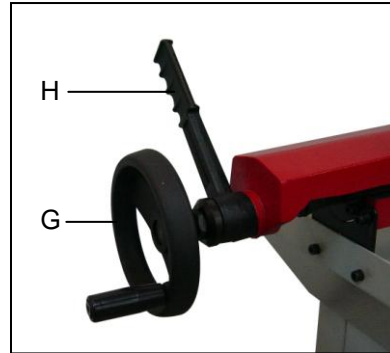

#### Clamping the Work Piece

- Place the work piece between the vise jaws and have it rest next to the fixed vise jaw.
- Rotate the hand wheel (G) clockwise to close the free vise jaw on to the work piece, and tighten.
- Rotate the hand wheel (G) counter-clockwise to release.
- Lever (H) can be used to rapidly lock and release the work piece by allowing a shallow gap between the vise and work piece. Then rotate lever (H) counter-clockwise to lock and clockwise to release.

For model PMS 170/210 MO with hydraulic cylinder

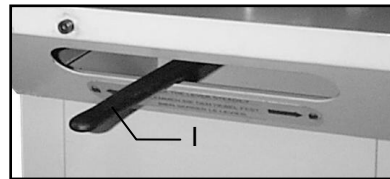
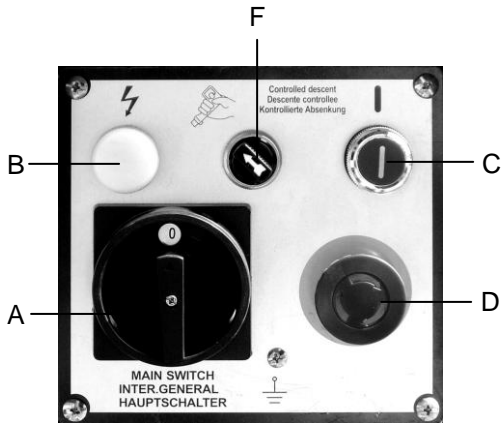

### 3.4 Cutting Angle Adjustment

#### Cutting at angles

- Angle can be cut up to 60°.
- Unlock lever (I) by pushing it to the left side.
- Rotate the saw bow to the desired angle by following the index on the scale.
- Lock lever (I) by pushing to the right side.

### 3.5 The Base

The base is a structure supporting the saw bow, the vise, the bar stop, the work piece supporter, pump, swing arm, and the coolant return plate for the support of the material. The base houses the cooling liquid tank.



- A. Main Connect Switch
- B. Power Indicator Light
- C. Start Push Button
- C1. Operating Indicator Light



## 4 OPERATING AND ADVICE ON USING YOUR BANDSAW

### 4.1 The Operation Cycle

Before operating the machine, all the main parts of the machine must be set to the optimum conditions.



The main connect switch is designed with a lock hole. A lock can be used in the lock hole to prevent operation of the machine for safety or security.

#### PMS 170/210 MO Operation Procedure:



- Raise the saw arm to the highest position.
- Load work piece and clamp it properly.
- Turn on main connect switch (A) to the ON position. Check to see that the indicator light (B) is lit.
- Press the trigger start switch (E) and indicator light (C1) will light. The coolant system should activate at the same time.
- Pull the manual operation handle (E) down to start cutting.
- After the cut is completed, release the trigger start switch (E) the machine will shut down. Manually raise the saw arm to the highest position for the next cut.

If an emergency situation should occur.

- Press the emergency push button (D) down to shut off all functions. To release the emergency pushbutton rotate the mushroom shaped button in the clock-wise direction. The button will pop up, then the cutting cycle can be restarted.

#### PMS 170/210 MO with hydraulic cylinder Operation Procedure:

PMS 170/210 MO with hydraulic cylinder is equipped with a hydraulic braking system and a bow weight adjusting system. This allows the machine to cut both

manually and semi-automatically.

#### A. Manual Operation

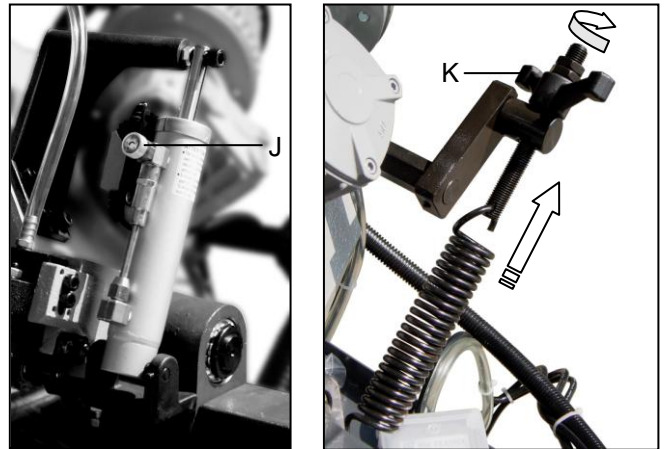

- Check that the hydraulic flow control knob (J) is fully closed.
- Reduce the bow weight. Rotate the wing nut (K) clockwise to increase the tension on the spring.
- Load work piece and clamp it properly.
- Turn on main connect switch (A) to the ON position. Check to see that the indicator light (B) is lit.
- Select manual control mode. Turn the control switch (F) to manual control mode for trigger operation.
- Hold the control handle of the saw bow.
- Fully open the flow control knob (J) by rotating counter-clockwise to the maximum.
- Squeeze the trigger on the control handle to start the blade and lower saw bow to begin cutting.
- When the saw bow reaches the bottom the micro-switch will activate and the blade will stop.
- Keep hold of the control handle to control the return to the start position.
- Turn the flow control knob (J) clockwise to close.
- The cutting operation is complete. Reset the workpiece to continue the next cutting cycle.

#### B. Semi-auto Cutting Operation

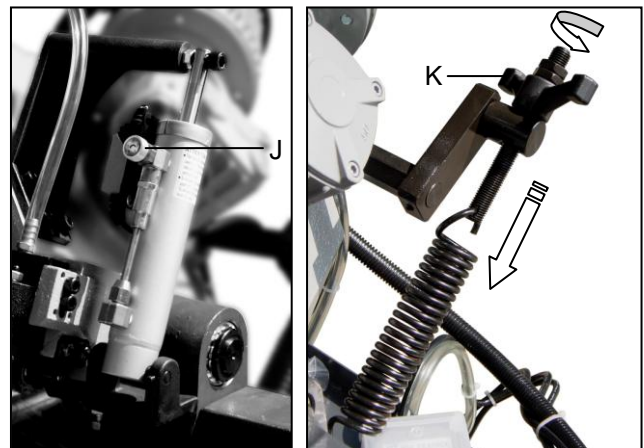

#### **!WARNING!**

Failure to fully close the hydraulic flow control knob (J)

can result in serious injury. The saw bow may drop suddenly when changing the spring tension.

- Check that the hydraulic flow control knob (J) is fully close.
- Increase the bow weight. Rotate the wing nut (K) counter clockwise to reduce the spring tension.
- Load work piece and clamp it properly.
- Turn main connect switch (A) to the ON position. Check to see that the indicator light (B) is lit.
- Select Hydraulic mode on control switch (F).
- Press the start button (C). The coolant system should activate at the same time.
- Slightly turn the hydraulic flow control knob (J) counter-clockwise from 2-3 to control the saw bow's descent rate.
- When the saw bow reaches the bottom the micro-switch will activate and the blade will stop.
- Lift the saw bow to the appropriate height close the hydraulic flow control knob (J) by rotating it clockwise all the way to the end.
- The machine is now ready for the next cutting operation.

If an emergency situation should occur:

- Press the emergency push button (D) down to shut off all functions. To release the emergency push button rotate the mushroom shaped button (D) clock-wise. The button will pop up, then the cutting cycle can be restarted.

#### 4.2 Recommendations for Using the Machine

The machine has been designed to cut metal building materials, with different shapes and profiles, used in workshop structures. Only on mechanical machine, that must sta

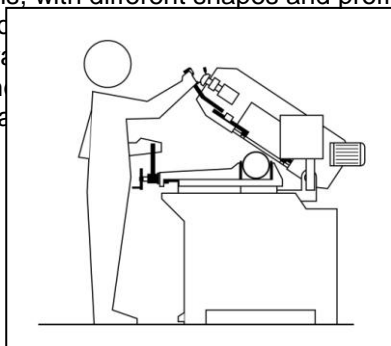

- Before starting each cutting operation, ensure that the part is firmly clamped in the vise and that the end is suitably supported.
- These figures below show examples of suitable clamping of different section bars, bearing in mind the cutting capacities of the machine in order to achieve a good efficiency and blade durability.

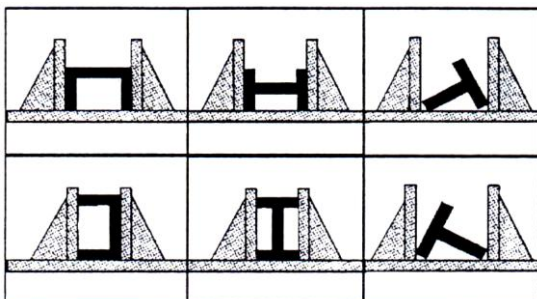

- Do not use blades of a different size from those stated in the machine specifications.
- If the blade gets stuck in the cut, release the running but ton immediately, switch off the machine, open the vise slowly, remove the part and check that the blade or its teeth are not broken. If they are broken, change the tool.
- Before performing any repairs on the machine, consult the dealer.

## 5 ADJUSTING YOUR MACHINE

### 5.1 Blade Tension Assembly

Blade tension is important to the proper operation of the saw. Proper blade tension is 700 to 900 kg/mm<sup>2</sup> as measured on a blade tension gauge.

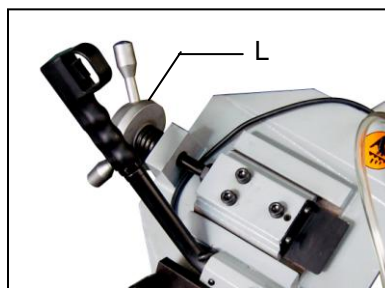

To set the blade tension without the use of a tension gauge:

- Disconnect the machine from the power source.
- Install blade between wheel and insert blade between bearings on blade guides.
- Tension blade slightly to remove any sag in blade between blade wheels.
- Turn blade tension knob (L) one and three quarter to two revolutions clockwise. To test press the flat side of the blade with your thumb, if moves with 2mm-3mm range then it is set correctly.
- After blade has been completely installed, close covers, connect the power source, and run saw for two to three minutes so blade can seat properly.
- Disconnect machine from the power source. Open cover and loosen blade just until it begins to sag.
- Tighten blade until it becomes straight between blade wheel and all sag has been eliminated.
- Tighten blade by turning blade tension wheel two full revolutions. Blade is now property tensioned and ready for use.

Close covers and connect machine to the power source.

## 5.2 Aligning the Flywheel

The flywheel's alignment may need adjustment to allow the saw blade to track correctly. Poor flywheel alignment can cause damage to the saw blade or to allow the blade to ride off the blade wheels.

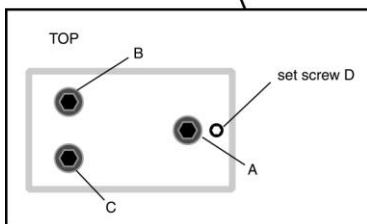

- Raise the saw bow to a usable work height.
- Disconnect the power supply.
- Loosen the Hex nut screws A, B, and C.
- Use an Allen wrench on setscrew D to adjust the tilt of the flywheel.
- Turning the setscrew, D clockwise will tilt flywheel so that the blade will ride closer to the flange.
- Turning the setscrew, D counter-clockwise will tilt the flywheel so that the blade will ride away from the flange. If the blade rides too far then it will come off.
- After the adjustment is finished, fasten the Hex nut screws in this order: A, B, and C.

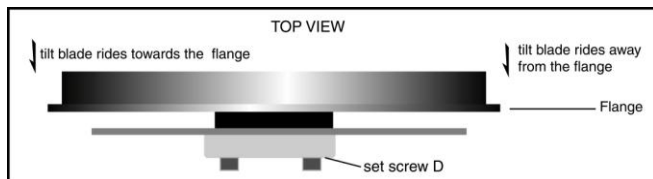

## 5.3 Checking the Adjustment of the Blade

Use a strip of scrap paper and slide it between the blade and the flywheel while it is running.

- If the paper is cut then the blade is riding too close to the flange. Readjust.
- If the paper folds or creases then the blade is seated properly.
- If you notice that the blade is riding away from the flange, then readjust.

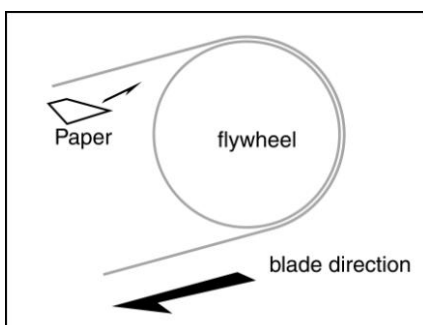

## 5.4 Adjusting the Blade Guide

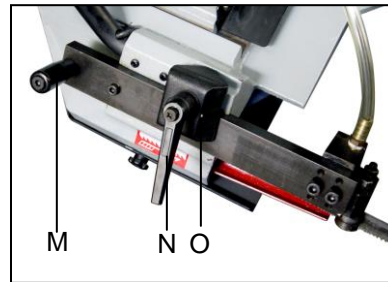

- Disconnect the machine from the power source.
- Release the extension bar for the blade guide block. Use the clamping handle (N) to loosen the clamping block (O).
- Hold the revolving handle (M) and slide the blade guide block to be as close as possible to the material without interfering with the cut.
- Tighten the clamping handle (N).
- Reconnect the machine to power source.

### Blade Guide Blocks

The blade is guided by means of roller bearings placed during inspection as per the thickness of the blade with a minimum amount of play.

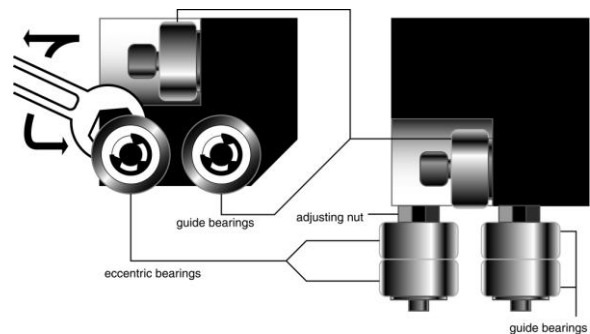

In case the blade needs to be replaced, make sure to always install 0.9mm thick blades for which the blade guide bearing have been adjusted. In the case of toothed blades with different thicknesses adjustment should be carried out as follows:

- From the bottom of the guide blocks, use a wrench on the adjusting nut of the eccentric bearing.
- Turning the adjusting nut clockwise will move the eccentric bearing away from the blade.
- Turning the adjusting nut counter-clockwise will move the eccentric bearing closer to the blade.

**BEFORE PERFORMING THE FOLLOWING OPERATIONS, THE ELECTRIC POWER SUPPLY AND THE POWER CABLE MUST BE COMPLETELY DISCONNECTED.**



## 5.5 Changing the Blade

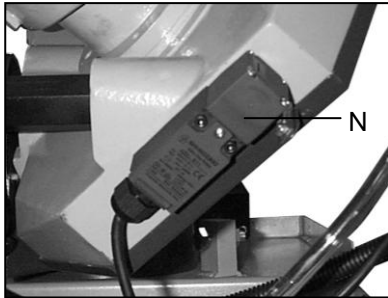

To change the blade:

- Lift the saw bow.
- Loosen the blade with the blade tension hand wheel, remove the mobile blade-guard cover, open the flywheel guards and remove the old blade from the flywheels and the blade guide blocks.
- Assemble the new blade by placing it first between the pads and then on the race of the flywheels, paying particular attention to the cutting direction of the teeth.
- Tension the blade and make sure it perfectly fits inside the seat of the flywheels.
- Assemble the mobile blade-guide end, the flywheel guard, and fasten it with the relative knobs. Check the safety micro-switch (N) is activated otherwise when electricity is applied the machine will not start.

BLADE CUTTING DIRECTION

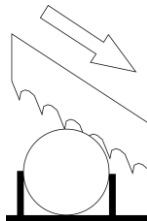

**WARNING:** Always assemble blades having dimensions specified in this manual and for which the blade guide heads have been set; otherwise, see chapter on "Description of the operating cycle" in the section Starting-up.

## 6 ROUTINE AND SPECIAL MAINTENANCE

THE MAINTENANCE JOBS ARE LISTED BELOW, DIVIDED INTO DAILY, WEEKLY, MONTHLY AND SIX-MONTHLY INTERVALS. IF THE FOLLOWING OPERATIONS ARE NEGLECTED, THE RESULT WILL BE PREMATURE WEAR OF THE MACHINE AND POOR PERFORMANCE.

### 6.1 Daily maintenance

- General cleaning of the machine to remove accumulated shavings.
- Clean the lubricating coolant drain hole to avoid excess fluid.
- Top off the level of lubricating coolant.
- Check blade for wear.

- Rise of saw frame to top position and partial slackening of the blade to avoid useless yield stress.
- Check functionality of the shields and emergency stops.

### 6.2 Weekly Maintenance

- Thorough cleaning of the machine to remove shavings, especially from the lubricant fluid tank.
- Removal of pump from its housing, cleaning of the suction filter and suction zone.
- Clean the filter of the pump suction head and the suction area.
- Use compressed air to clean the blade guides (guide bearings and drain hole of the lubricating cooling).
- Cleaning flywheel housings and blade sliding surfaces on flywheels.

### 6.3 Monthly Maintenance

- Check the tightening of the motor flywheel screws.
- Check that the blade guide bearings on the heads are perfect running condition.
- Check the tightening of the screws of the gear motor, pump, and accident protection guarding.

### 6.4 Six-Monthly Maintenance

- Continuity test of the equipotential protection circuit.

### 6.5 Oils for Lubricating Coolant

Considering the vast range of products on the market, the user can choose the one most suited to their own requirements, using as reference the type SHELL LUTEM OIL ECO. THE MINIMUM PERCENTAGE OF OIL DILUTED IN WATER IS 8 - 10 %.

### 6.6 Oil Disposal

The disposal of these products is controlled by strict regulations. Please see the Chapter on "Machine dimensions Transport - Installation" in the section on *Dismantling*.

### 6.7 Coolant system

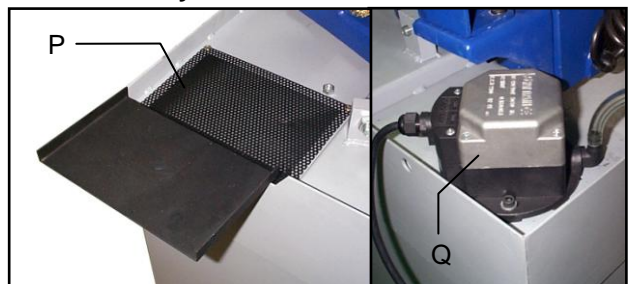

Cleaning the tank

- Use hex wrench to open the plug located on the base below the pump. Allow the coolant to drain-out.
- Remove the grate (P) by loosening the four setscrews.
- Remove the pump (Q) by loosening the four setscrews.
- Use a vacuum cleaner to vacuum chips and debris from the tank.
- Replace the plug.
- Thoroughly clean the pump (Q) and replace.
- Fill the tank with coolant to approximately 25mm

- below the grate (P).
- Replace the grate (P).

### 6.8 The Gearbox

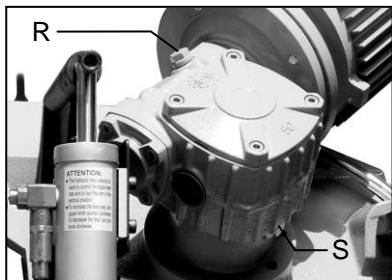

The gearbox requires periodic changing of oil. The oil must be changed by the first 6 months of a new machine and every year thereafter.

To change the gear box oil

- Disconnect the machine from the power source.
- Raise the saw bow to vertical position.
- Release the drain hole (S) to draw off gear oil by loosening the oil fill bolt (R).
- Replace the drain plug bolt (S) after oil completely flows off.
- Place the saw bow back to horizontal position.
- Fill Gear box with approximately .3 liter of gear oil through the hole of the oil fill bolt (R).

For reference, use SHELL type gear oil or Mobile gear oil #90.

### 6.9 Special Maintenance

Special maintenance must be conducted by skilled personnel. We advise contacting your nearest dealer and/or importer. Also the reset of protective and safety equipment and devices (of the reducer), the motor, the motor pump, and other electrical components requires special maintenance.

## 7 TECHNICAL CHARACTERISTICS

### 7.1 Table of Cutting Capacity and Technical Details

CUTTING CAPACITY			
0°	170	170 x 170	210 x 95
45°	120	110 x 110	
60°	70	60 x 60	

ELECTRIC MOTOR-BLADE ROTATION	kW	0.75
FLYWHEEL DIAMETER	mm	260
BLADE DIMENSIONS	mm	20x0.9x2110
BLADE SPEED CUTTING	m/min	40 / 80
OPENING VICE	mm	215
SAW FRAME TILTING	°	50
WORKING TABLE HEIGHT	mm	890
MACHINE WEIGHT	kg	156

USE	TYPES OF STEEL					CHARACTERISTICS		
	I UNI	D DIN	F AF NOR	GB SB	USA. AISI-SAE	Hardness BRINELL HB	Hardness ROCKWELL HRB	R=N/mm <sup>2</sup>
Construction steels	Fe360	St37	E24	----	----	116	67	360÷480
	Fe430	St44	E28	43	----	148	80	430÷560
	Fe510	St52	E36	50	----	180	88	510÷660
Carbon steels	C20	CK20	XC20	060 A 20	1020	198	93	540÷690
	C40	CK40	XC42H1	060 A 40	1040	198	93	700÷840
	C50	CK50	----	----	1050	202	94	760÷900
	C60	CK60	XC55	060 A 62	1060	202	94	830÷980
Spring steels	50CrV4	50CrV4	50CV4	735 A 50	6150	207	95	1140÷1330
	60SiCr8	60SiCr7	----	----	9262	224	98	1220÷1400
Alloyed steels for hardening and tempering and for nitriding	35CrMo4	34CrMo4	35CD4	708 A 37	4135	220	98	780÷930
	39NiCrMo4	36CrNiMo4	39NCD4	----	9840	228	99	880÷1080
	41CrAlMo7	41CrAlMo7	40CADG12	905 M 39	----	232	100	930÷1130
Alloyed casehardening steels	18NiCrMo7	----	20NCD7	En 325	4320	232	100	760÷1030
	20NiCrMo2	21NiCrMo2	20NCD2	805 H 20	4315	224	98	690÷980
Alloyed for bearings	100Cr6	100Cr6	100C6	534 A 99	52100	207	95	690÷980
Tool steel	52NiCrMoKU	56NiCrMoV7C100K	----	----	----	244	102	800÷1030
	C100KU	C100W1	----	BS 1	----	212	96	710÷980
	X210Cr13KU	X210Cr12	Z200C12	BD2-BD3	S-1	252	103	820÷1060
	58SiMo8KU	----	Y60SC7	----	S5	244	102	800÷1030
Stainless steels	X12Cr13	4001	----	----	410	202	94	670÷885
	X5CrNi1810	4301	Z5CN18.09	304 C 12	304	202	94	590÷685
	X8CrNi1910	----	----	----	----	202	94	540÷685
	X8CrNiMo1713	4401	Z6CDN17.12	316 S 16	316	202	94	490÷685
Copper alloys Special brass Bronze	Aluminium copper alloy G-CuAl11Fe4Ni4 UNI 5275					220	98	620÷685
	Special manganese/silicon brass G-CuZn36Si1Pb1 UNI5038					140	77	375÷440
	Manganese bronze SAE43 - SAE430					120	69	320÷410
	Phosphor bronze G-CuSn12 UNI 7013/2a					100	56,5	265÷314
Cast iron	Gray pig iron G25					212	96	245
	Spheroidal graphite cast iron GS600					232	100	600
	Malleable cast iron W40-05					222	98	420

## 8 MATERIAL CLASSIFICATION AND CHOICE OF TOOL

Since the aim is to obtain excellent cutting quality, the various parameters such as hardness of the material, shape and thickness, transverse cutting section of the part to be cut, selection of the type of cutting blade, cutting speed and control of saw frame lowering.

These specifications must therefore be harmoniously combined in a single operating condition according to practical considerations and common sense, so as to achieve an optimum condition that does not require countless operations to prepare the machine when there are many variations in the job to be performed. The various problems that crop up from time to time will be solved more easily if the operator has a good knowledge of these specifications.

### 8.1 Definition of materials

The table above lists the characteristics of the materials to be cut. So that the correct tools to use, can be chosen.

### 8.2 Selecting blade

First of all the pitch of the teeth must be chosen, in other words, the number of teeth per inch (25,4 mm) suitable for the material to be cut, according to these criteria:



- Parts with a thin and/or variable section such as profiles, pipes and plate, need close toothing, so that the number of teeth used simultaneously in cutting is from 3 to 6;
- Parts with large transverse sections and solid sections need widely spaced toothing to allow for the greater volume of the shavings and better tooth penetration;
- Parts made of soft material or plastic (light alloys, mild bronze, Teflon, wood, etc.) also require widely spaced toothing;
- Pieces cut in bundles require combo tooth design.

### 8.3 Teeth pitch

As already stated, this depends on the following factors:



- **Hardness of the material**
- **Dimensions of the section**
- **Wall thickness.**

BLADE TEETH SELECTION TABLE		
THICKNESS MM	Z CONTINUOUS TOOTH DESIGN	Z COMBO TOOTH DESIGN
TILL 1.5	14	10/14
FROM 1 TO 2	8	8/12
FROM 2 TO 3	6	6/10
FROM 3 TO 5	6	5/8
FROM 4 TO 6	6	4/6
MORE THAN 6	4	4/6

S = THICKNESS

SOLID Ø OR L MM	Z CONTINUOUS TOOTH DESIGN	Z COMBO TOOTH DESIGN
TILL 30	8	5/8
FROM 30 TO 60	6	4/6
FROM 40 TO 80	4	4/6
MORE THAN 90	3	3/4

Ø = DIAMETER    L = WIDTH

### 8.4 Cutting and advance speed

The cutting speed (m/min) and the advance speed (cm<sup>2</sup>/min = area traveled by the disk teeth when removing shavings) are limited by the development of heat close to the tips of the teeth.

- The cutting speed is subordinate to the resistance of the material ( $R = N/mm^2$ ), to its hardness (HRC) and to the dimensions of the widest section.
- Too high an advance speed (= lowering of the saw frame) tends to cause the disk to deviate from the ideal cutting path, producing non rectilinear cuts on both the vertical and the horizontal plane.

The best combination of these two parameters can be seen directly examining the chips.

Long spiral-shaped chips indicate ideal cutting.

Very fine or pulverized chips indicate lack of feed and/or cutting pressure.

Thick and/or blue chips indicate overload of the blade.

### 8.5 Blade running-in

**When cutting for the first time, it is good practice to run in the tool making a series of cuts at a low advance speed (= 30-35 cm<sup>2</sup>/min on material of average dimensions with respect to the cutting capacity and solid section of normal steel with  $R = 410-510 N/mm^2$ ). Generously spraying the cutting area with lubricating coolant.**

### 8.6 Blade structure

Bi-metal blades are the most commonly used. They consist of a silicon-steel blade backing by a laser welded high speed steel (HSS) cutting edge. The type of stocks are classified in M2, M42, M51 and differ from each other because of their major hardness due to the increasing percentage of Cobalt (Cc) and molybdenum (Mo) contained in the metal alloy

### 8.7 Blade type

They differ essentially in their constructive characteristics, such as:

- **Shape** and cutting angle of tooth
- **Pitch**
- **Set**

**Shape and angle of tooth**

**REGULAR TOOTH:** 0° rake and constant pitch.





Most common form for transversal or inclined cutting of solid small and average cross-sections or pipes, in laminated mild steel and gray iron or general metal.

**POSITIVE RAKE TOOTH:** 9° - 10° positive rake and constant pitch.

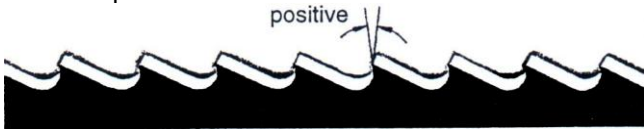

Particular use for crosswise or inclined cuts in solid sections or large pipes, but above all harder materials (highly alloyed and stainless steels, special bronze and forge pig iron).

**COMBO TOOTH:** pitch varies between teeth and consequently varying teeth size and varying gullet depths. Pitch varies between teeth, which ensures a smoother, quieter cut and longer blade life owing to the lack of vibration.

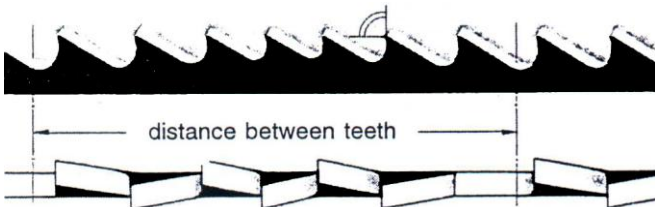

Another advantage offered in the use of this type of blade in the fact that with an only blade it is possible to cut a wide range of different materials in size and type.

**COMBO TOOTH:** 9° - 10° positive rake.

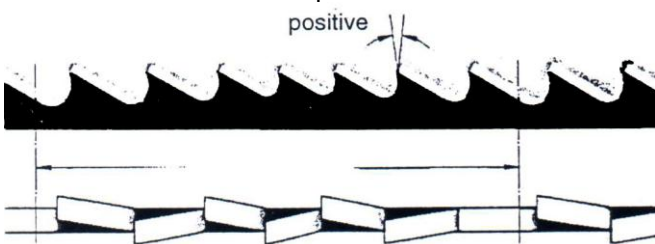

This type of blade is the most suitable for the cutting of section bars and large and thick pipes as well as for

## 9 NOISE TESTS

The test was held under environmental noise levels of 65db. Noise measurements with the machine operating unload was 71db. Noise level during the cutting of mild carbon steel was 73db.

NOTE: with the machine operating, the noise level will vary according to the different materials being processed. The user must therefore assess the intensity and if necessary provide the operators with the necessary personal protection, as required by Law 277/1991.

the cutting of solid bars at maximum machine capacity. Available pitches: 3-4/4-6.

### SETS

Saw teeth bent out of the plane of the saw body, resulting in a wide cut in the workpiece.



**REGULAR OR RAKER SET:** Cutting teeth right and left, alternated by a straight tooth.



Of general use for materials with dimensions superior to 5 mm. Used for the cutting of steel, castings and hard nonferrous materials.

**WAVY SET:** Set in smooth waves.



This set is associated with very fine teeth and it is mainly used for the cutting of pipes and thin section bars (from 1 to 3 mm).

**ALTERNATE SET (IN GROUPS):** Groups of cutting teeth right and left, alternated by a straight tooth.



This set is associated with very fine teeth and it is used for extremely thin materials (less than 1mm).

**ALTERNATE SET (INDIVIDUAL TEETH):** Cutting teeth right and left.



This set is used for the cutting of nonferrous soft materials, plastics and wood.



## **10 WIRING DIAGRAMS**

Model PMS 170/210 MO

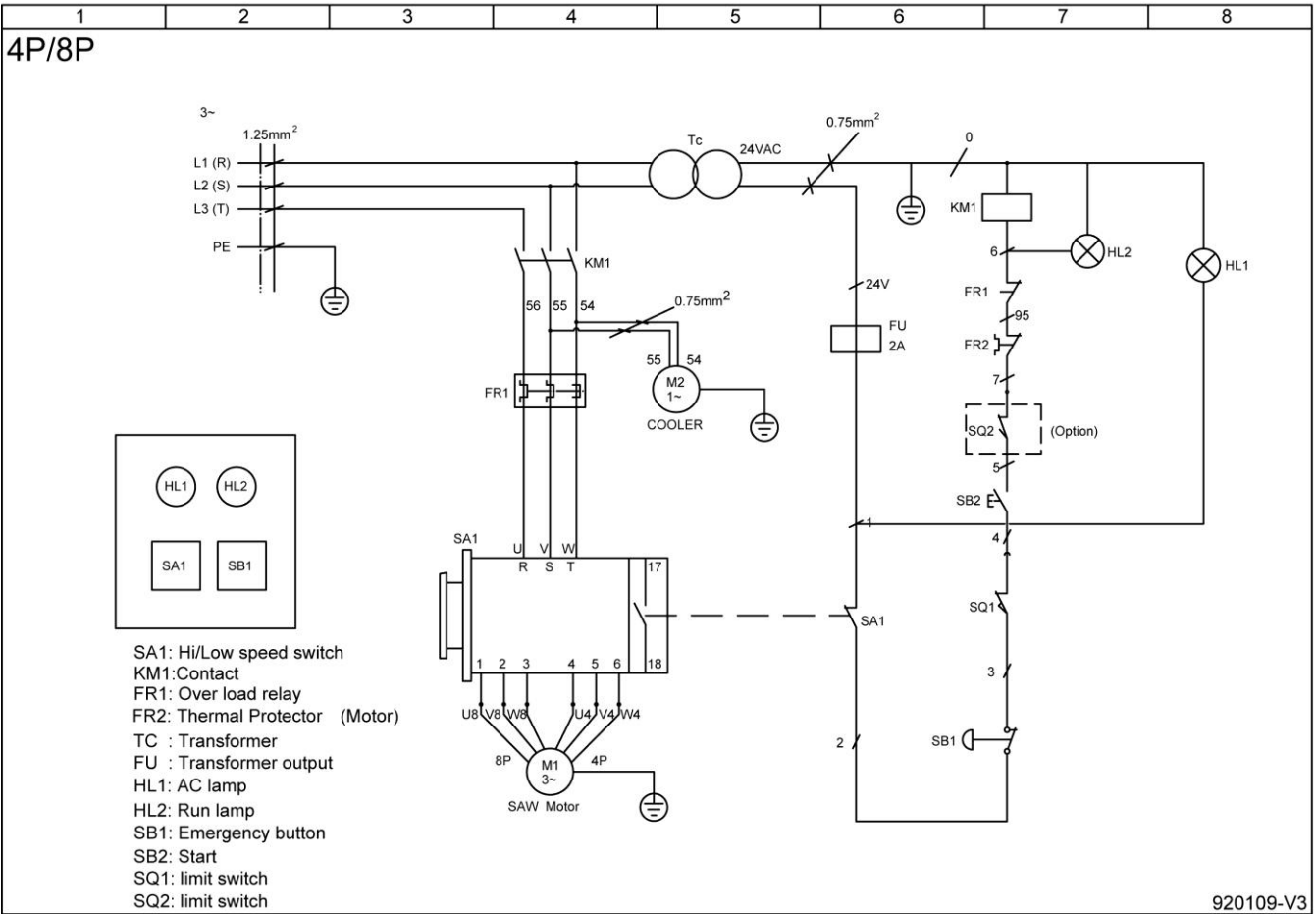
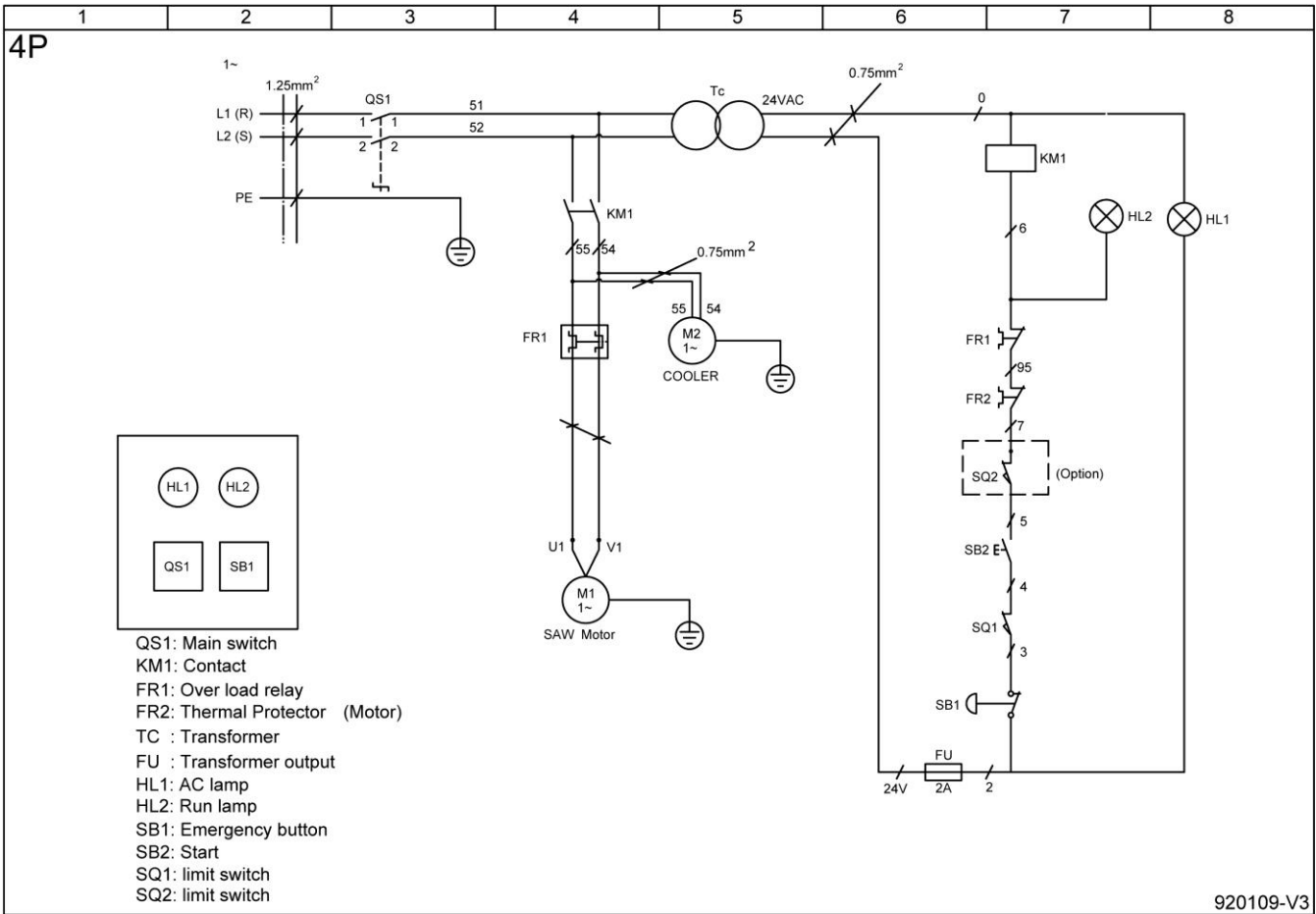

Model PMS 170/210 MO with hydraulic cylinder

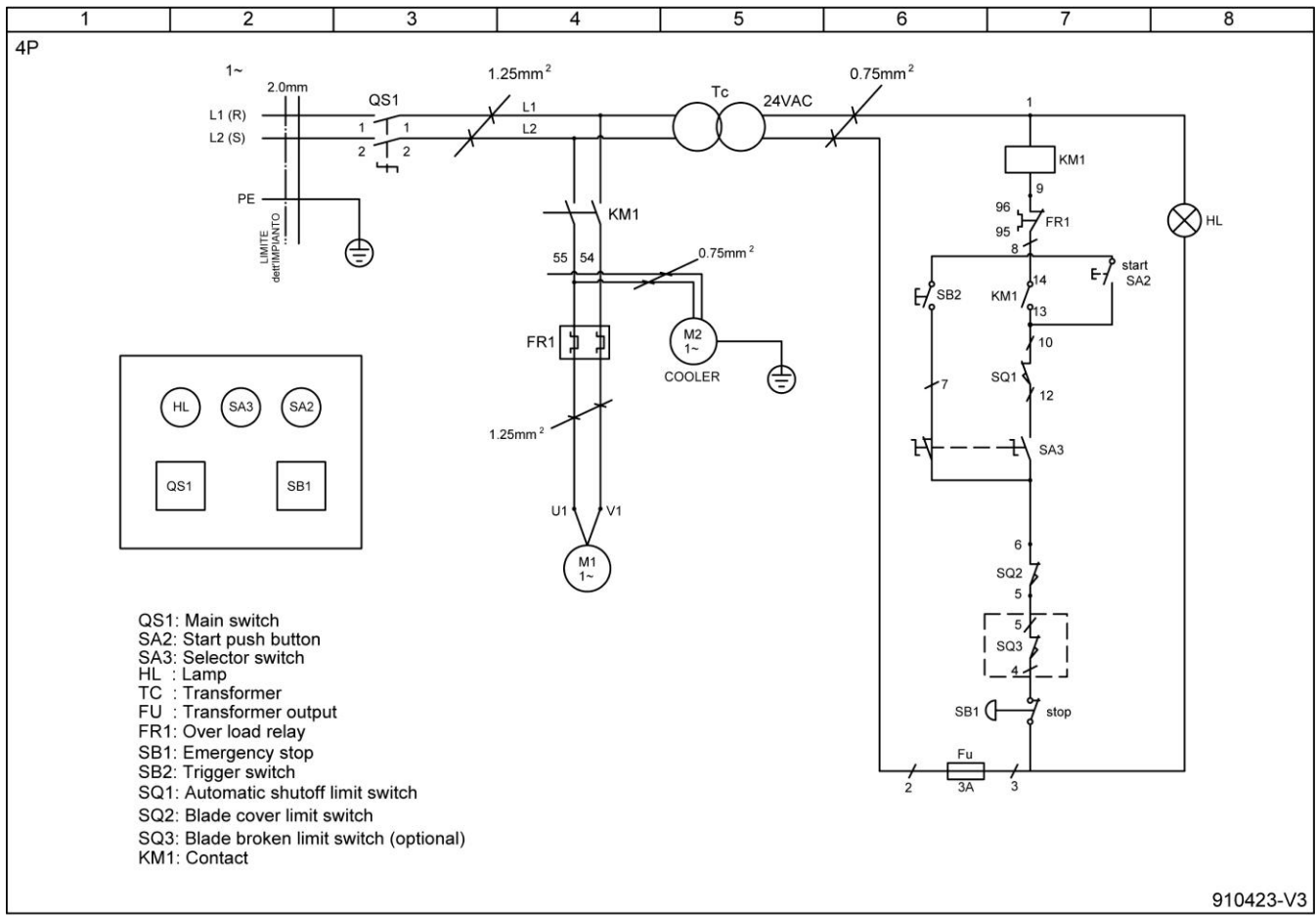

910423-V3

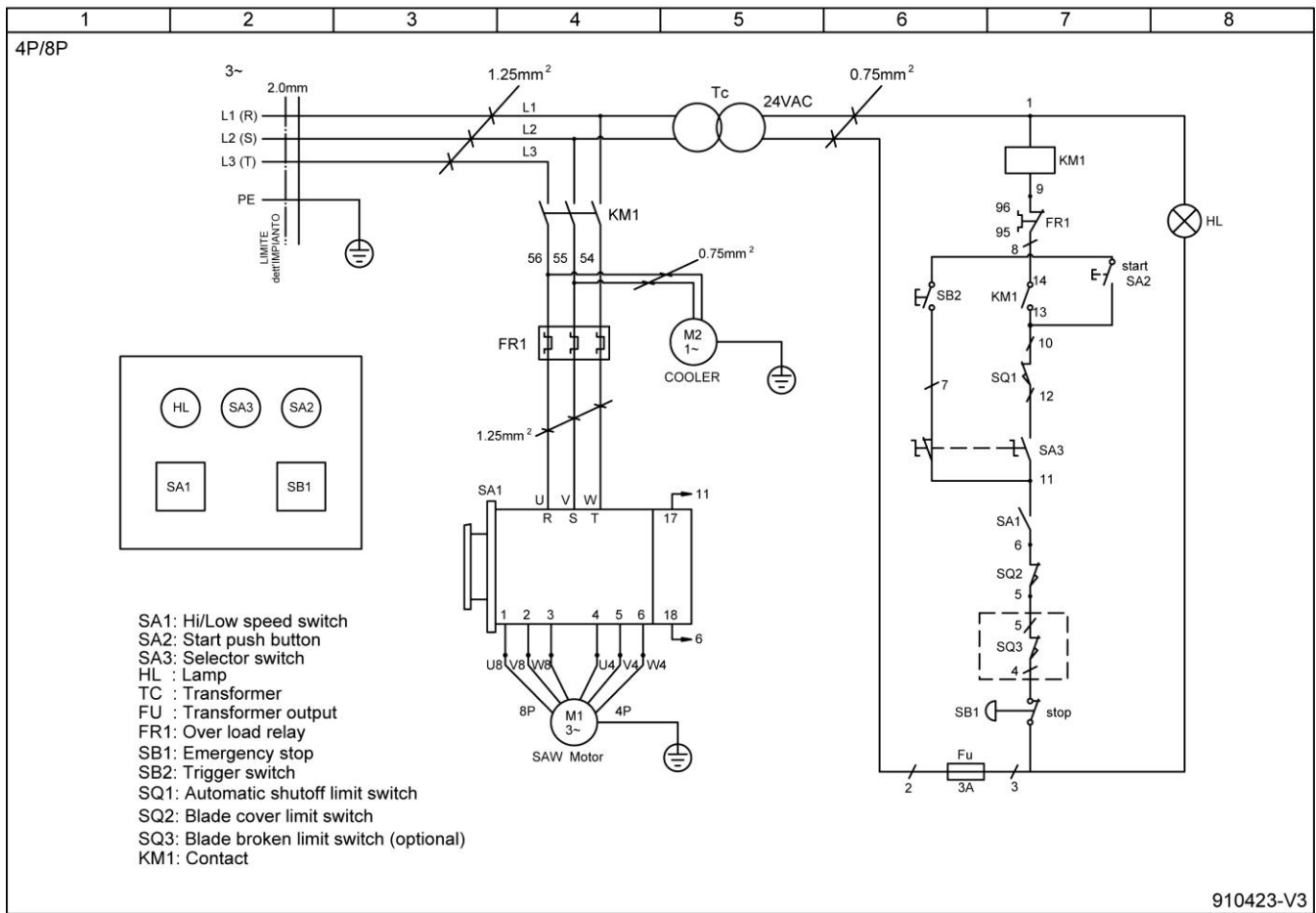

910423-V3

## 11 TROUBLESHOOTING

This chapter lists the probable faults and malfunctions that could occur while the machine is being used and suggests possible remedies for solving them.

The first paragraph provides diagnosis for TOOLS and CUTS the second for ELECTRICAL COMPONENTS.

**11.1 - Electrical components diagnosis**

**Model PMS 170/210 MO  
FAULT**

<b>THE BAND ROTATION MOTOR DOES NOT WORK</b>	<b>PROBABLE CAUSE</b>	<b>REMEDY</b>
	<p>“SA1” speed switch (3 phase only)</p> <p>“FR1” band motor over-load relay</p> <p>“SB1” emergency switch</p> <p>“SB2” start push button</p> <p>Band motor temperature relay</p>	<p>It must be exactly turned towards Rabbit or Turtle sign.</p> <p>Push down FR1 red button. After a motor cooling time of 5 minutes, if there is no current continuity on these two wires, the motor must be replaced.</p> <p>Reset emergency switch (see operation procedure).</p> <p>Check the functioning and/or possible damages. If so, replace it.</p> <p>Check for current continuity on both wires of the probe after a motor cooling time of 10 – 15 minutes. If there is no current continuity on these two wires, the motor must be replaced or rewound.</p>

<b>MACHINE DOES NOT WORK</b>	<p>Fuses “FU”</p> <p>“SQ1” blade cover limit switch</p> <p>“SQ2” blade broken limit switch (optional)</p> <p>Speed switch “SA1” in position “0”</p>	<p>Check electrical efficiency. If not, replace the fuse.</p> <p>Check closing of the fly wheel cover. Check the efficiency of the device; replace it if damaged.</p> <p>Check the efficiency of the device; replace it if damaged.</p> <p>It must be exactly turned to Rabbit or Turtle sign.</p>
	<p>Fuses “FU”</p> <p>“SQ1” Automatic shutoff limit switch</p> <p>“SQ2” blade cover limit switch</p> <p>“SQ3” blade broken limit switch (optional)</p>	<p>Reset the emergency switch by following the steps of Operation Procedure. Check electrical efficiency, if not, replace it.</p> <p>Check the efficiency of the device; replace it if damaged.</p> <p>Check current continuity on the two wires in the prone, if not, replace the motor.</p>

<b>MOTOR STOPPED WITH PILOT LIGHT “HL2” LIT</b>	<p>Speed switch “SA1” in position “0”</p> <p>Emergency button “SB1” on</p>	<p>Check the efficiency of the device; replace it if damaged.</p> <p>Check that it is not burnt and that it turns freely. Replace it if damaged.</p>
---	--	--

**Model PMS 170/210 MO with  
FAULT  
PROBABLE CAUSE**

<p>“SB2” trigger switch</p> <p>Motor “M1”</p>	<p><b>hydraulic cylinder REMEDY</b></p>
---	---



**THE BAND ROTATION  
MOTOR DOES NOT WORK**



Too fast advance

Wrong cutting speed

Wrong tooth pitch

Chips sticking onto teeth and in the  
gullets or material that gums

Defects on the material or material too  
hard

Ineffective gripping of the part in the  
vise

The blade gets stuck in the material

Starting cut on sharp or irregular  
section bars

Poor quality blade

Previously broken tooth left in the cut

Cutting resumed on a groove made  
previously

Vibrations

Wrong tooth pitch or shape

“SB2” trigger switch

Motor “M 1”

Teeth positioned in the direction  
opposite the cutting direction

**MACHINE DOES NOT WORK**

**MOTOR STOPPED WITH  
PILOT LIGHT “HL2” LIT**

**11.2 - Blade and cut diagnosis  
FAULT**

**PROBABLE CAUSE  
FAULT  
PROBABLE CAUSE**

**REMEDY**

**REMEDY**

**PREMATURE BLADE WEAR**



Decrease advance, exerting less cutting pressure. Adjust the braking

Faulty running-in of blade

Teeth positioned in the direction opposite the cutting direction

Poor quality blade

Too fast advance

Wrong cutting speed

Defects on the material or material too hard

Insufficient lubricating refrigerant or wrong emulsion

See "Material classification and blade selection" in the *Blade running-in* section.

Turn teeth in correct direction.

Use a superior quality blade.

Decrease advance, exerting less cutting pressure. Adjust the braking device.

Change speed and/or type of blade. See chapter on "Material classification and blade selection," in the section *Blade selection table according to cutting and feed speed*.

Material surfaces can be oxidized or covered with impurities making them, at the beginning of the cut, harder than the blade itself, or have hardened areas or inclusions inside the section due to productive agents used such as casting sand, welding wastes, etc. Avoid cutting these materials or perform cutting with extreme care, cleaning and remove such impurities as quickly as possible.

Check level of liquid in the tank. Increase the flow of lubricating coolant, checking that the coolant nozzle and pipe are not blocked. Check the emulsion percentage.

Pay more attention when you start

**BLADE BREAKAGE**

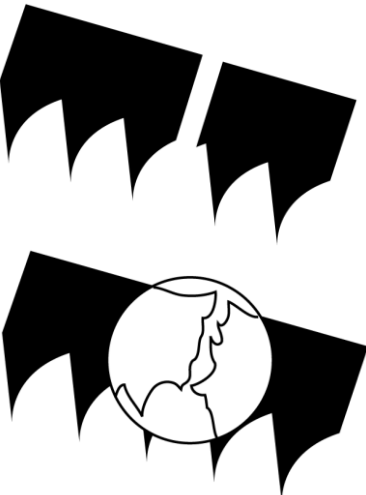

Faulty welding of blade

Too fast advance

Wrong cutting speed

Wrong tooth pitch

Ineffective gripping of the part in the vice

Blade touching material at beginning of cut

Remedy

The welding of the blade is of utmost importance. The meeting surfaces must perfectly match and once they are welded they must have no inclusions or bubbles; the welded part must be perfectly smooth and even. They must be evenly thick and have no bulges that can cause dents or instant breakage when sliding between the blade guide pads.

Decrease advance, exerting less cutting pressure. Adjust the braking device.

Change speed and/or type of blade.

See chapter on "Material classification and blade selection", in the section *Blade selection table according to cutting and feed speed*.

Choose a suitable blade. See Chapter "Material classification and blade selection."

Check the gripping of the part.

At the beginning of the cutting process, never lower the saw bow before starting the blade motor.

**FAULT**

**PROBABLE CAUSE**

**REMEDY**

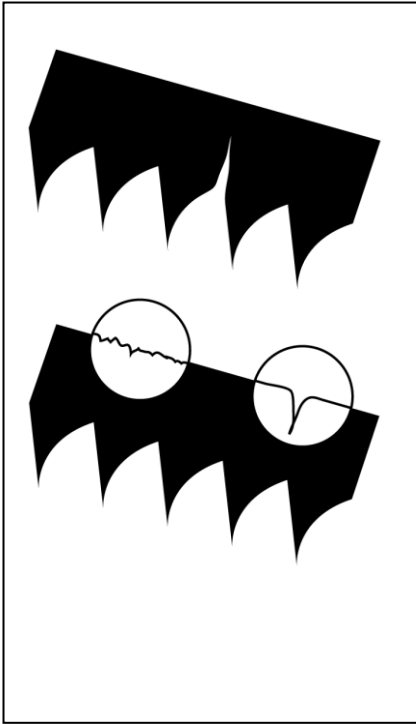

Blade guide pads not regulated or dirty because of lack of maintenance

Blade guide block too far from material to be cut

Improper position of blade on flywheels

Insufficient lubricating coolant or wrong emulsion

Check distance between pads (see "Machine adjustments" in the *Blade Guide Blocks* section): extremely accurate guiding may cause cracks and breakage of the tooth. Use extreme care when cleaning.

Approach head as near as possible to material to be cut so that only the blade section employed in the cut is free, this will prevent deflections that would excessively stress the blade.

The back of blade rubs against the support due to deformed or poorly welded bands (tapered), causing cracks and swelling of the back contour.

Check level of liquid in the tank. Increase the flow of lubricating refrigerant, checking that the hole and the liquid outlet pipe are not blocked. Check the emulsion percentage.

**STEAKED OR ETCHED BANDS**

Damaged or chipped blade guide pads

Tight or slackened blade guide bearings.

Replace them.

Adjust them (see Chapter "Machine adjustments" in *Blade guide* section).

**CUTS OFF THE STRAIGHT**

Blade not parallel as to the counter service

Blade not perpendicular due to the excessive play between the guide pads and maladjustment of the blocks

Too fast advance

Worn out blade

Wrong tooth pitch

Check fastenings of the blade guide blocks as to the counter-vice so that they are not too loose and adjust blocks vertically; bring into line the position of the degrees and if necessary adjust the stop screws of the degree cuts.

Check and vertically re-adjust the blade guide blocks; reset proper side guide play (see Chapter "Machine adjustments" in *Blade guide* section).

Decrease advance, exerting less cutting pressure. Adjust the braking device.

Approach it as near as possible to material to be cut so that only the blade section employed in the cut is free, this will prevent deflections that would excessively stress the blade.

Replace it. Blade with major density of teeth is being used, try using one with less teeth (see Chapter "Material classification and blade selection" in the *Blade Types* section).

**FAULT**

**PROBABLE CAUSE**

**REMEDY**

--

Broken teeth
Insufficient lubricating refrigerant or wrong emulsion

Irregular work of the blade due to the lack of teeth can cause deflection in the cut; check blade and if necessary replace it.
Check level of liquid in the tank. Increase the flow of lubricating coolant, checking that the hole and the liquid outlet pipe are not blocked. Check the emulsion <i>percentage</i> .

<b>FAULTY CUT</b>
-------------------

Worn out flywheels Flywheel housing full of chips
--

The support and guide flange of the band are so worn out that they cannot ensure the alignment of the blade, causing faulty cutting; blade rolling and drawing tracks can have become tapered. Replace them. Clean with compressed air.
---

<b>STREAKED CUTTING SURFACE</b>

Too fast advance
Poor quality blade
Worn out blade or with chipped and/or broken teeth
Wrong tooth pitch
Blade guide block too far from material to be cut
Insufficient lubricating coolant or wrong emulsion

Decrease advance, exerting less cutting pressure. Adjust the braking device.
Use a superior quality blade.
Replace it.
Blade used probably has too large teeth, use one with more teeth (see " <b>Material classification and blade selection</b> " in the <i>Blade Types</i> section).
Approach it as near as possible to material to be cut so that only the blade section employed in the cut is free, this will prevent deflections that would excessively stress the blade.
Check level of liquid in the tank. Increase the flow of lubricating coolant, checking that the hole and the liquid outlet pipe are not blocked. Check the emulsion percentage.

<b>NOISE ON GUIDE BLOCKS</b>
------------------------------

Chipped bearings Worn out or damaged pads
--

Dirt and/or chips between blade and guide bearings. Replace them. Replace them.
---



## PART LIST

Part No.	Description	Size No.	Q'ty	Part No.	Description	Size No.	Q'ty
1	Base (Right Part)		1	56	Nut	M20	1
1-1	Base (Left Part)		1	56-1	Set Screw	M5x5	1
2	Hex. Cap Bolt	M12x40	2	57	Bearing Bushing		1
3	Nut	M12	2	58	Ball Bearing	#51104	1
4	Base Cover Plate		2	59	Lock Handle		1
5	Hex. Cap Bolt	M8x16	8	60	Bushing		1
6	Flat Washer	M8x18x2	16	61	Hex. Socket Cap Screw	M6x100x28	2
7	Nut	M8	8	62	Movable Vise		1
8	Flat Washer	M10x21x2	2	63	Compressed Spring		1
9	Spring Washer	M10	2	64	Lead Screw		1
10	Hex. Socket Cap Screw	M10x20	2	64-1	Key	5x5x15	1
11	Hex. Socket Cap Screw	M6x8	2	64-2	Flat Washer	M8	1
12	Plate		1	64-3	Hex. Socket Cap Screw	M8x16	1
13	Hex. Socket Cap Screw	M8x20	2	66	Vise Table		1
14	Spring Washer	M8	2	67	Set Screw	M8x10	1
15	Hex. Socket Cap Screw	M8x20	2	68	Hex. Socket Cap Screw	M5x8	2
15-1	Spring Washer	M8	2	69	Scale Point		1
16	Flat Washer	M8x18x2	2	70	Set Screw	M8x10	1
17	Supporting Plate		1	71	Pivot		1
18	Nut	M8	2	72	Anti-Bust Cover	Ø30	2
18-1	Flat Washer	M8x18x2	2	73	Ball Bearing	#32006	2
19-1	Support Plate		1	74	Nut	M10	2
19-2	Hex. Cap Bolt	M10x20	2	75	Hex. Cap Bolt	M10x40	1
19-3	Spring Washer	M10	2	75-1	Hex. Cap Bolt	M10x25	1
19-4	Flat Washer	M10x21x2	2	76	Spring Hook		1
28	Block Plate		1	77	Star Washer	Ø30	1
31	Hex. Cap Bolt	M12x40	2	78	Nut	M30	1
32	Nut	M12	2	79	Swing Arm		1
33	Filter Net		1	80	Scale		1
34	Round Head Screw	M5x10	4	81	Rivet	2.3x4	2
35	Hex. Socket Cap Screw	M6x25	2	82	Bar-Stop-Rod		1
36	Flat Washer	M6	2	83	Rod		1
37	Hose	5/16"x125cm	1	84	Butterfly Screw	5/16x3/4	1
38	Hose Clamp		1	85	Cover		1
39	Pump		1	86	Hex. Socket Cap Screw	M5x8	4
40	Plug	M3/8"	1	88	Round Head Screw	M5x8	2
41	Coolant and Chip Tray		1	89	Control Box Bottom Plate		1
42	Locking Lever		1	90-1	Transformer		1
43	Set Screw	M10x16	1	90-2	Magnetic Connector		1
44	Spring Washer	M10	1	90-3	Fuse Seat		1
45	Hex. Socket Cap Screw	M10x35	1	90-4	Overload Rely		1
46	Nut		1	90-5	Terminal Connector		1
47	Shaft		1	91	Round Head Screw	M5x8	4
48	Oil Seal	4m/m(51.7-52cm)	1	92-1	Main Connect Switch	3PH	1
50	Disk		1	92-1A	0-1 Power Switch (not shown)	1PH	1
51	Spring Washer	M8	4	92-2	Power Indicator Light		1
52	Hex. Socket Cap Screw	M8x30	4	92-3	Emergency Switch		1
53	Set Screw	M8x10	1	92-4	Operating Indicator Light		1
54	Hand Wheel	5-1/2"	1	93	Control Box Panel		1
55	Set Screw	M8x10	1	93-H	Control Box Panel		1

951021

## PART LIST

Part No.	Description	Size No.	Q'ty	Part No.	Description	Size No.	Q'ty
93-H1	Manual/ Auto Selector		1	145A	Saw Arm		1
93-H2	Start Button		1	145-1	Set Shaft		1
94	Control Box Bottom Part		1	146	Hose	5/16"x75cm	1
94-1	Plug (for WE-210S)	HP-16	1	147	Pipe Fitting	1/4Px5/16	2
95	Support		1	148A	Pipe Fitting Seat		1
96	Setting Bracket		1	150	Coolant Switch	1/4Px5/16	1
97	Spring Washer	M8	2	150-1	Brace		1
98	Hex. Socket Cap Screw	M8x20	2	150-2	Hex. Socket Cap Screw	M6x12	2
99	Spring Washer	M8	4	151	Hose Clamp		1
100	Hex. Socket Cap Screw	M8x20	4	152	Hose	5/16"x35cm	1
101	Hex. Socket Cap Screw	M5x8	4	153	Limit Switch		1
103	Front Ball Bearing Bracket		1	153-1	Switch Pin		1
104	Setting Bracket		1	154	Hex. Socket Cap Screw	M4x35	2
105	Handle	M10x45	1	155	Spring Shaft		1
106	Hex. Socket Cap Screw	M6x8	1	155-H1	Spring Shaft		1
107	Plastic Handle	M6	1	155-H2	Setting Plate		1
108	Spring Washer	M8	3	155-H3	Handle		1
109	Hex. Socket Cap Screw	M8x25	3	155-H4	Nut	M16x2.0x8t	2
110	Set Screw	M8x30	2	155-H5	Bushing		1
114	Rod		1	155-H6	Adjustable Shaft		1
115	Nut	M16x2	1	155-H7	Spring		1
116	Trigger Switch		1	155-H8	Set Screw	M8x10	3
117	Cover Plate		1	156	Spring		1
118	Hex. Socket Cap Screw	M6x8	2	157	Key	7x7x25	1
119	Set Screw	M10x25	1	158	Gear Box		1
120	Hex. Socket Cap Screw	M10x40	3	159	Key	5x5x25	1
121	Spring Washer	M10	3	160	Motor		1
122A	Slide		1	161	Spring Washer	M8	4
123	Nut	M16x2	1	162	Hex. Cap Bolt	M8x25	4
124	Handle		2	163	Set Screw	M6x12	4
125	Handle Wheel		1	170	Set Screw	M6x12	4
126	Thrust Spring Washer		8	172	Hex. Socket Cap Screw	M8x25	2
127	Tension Shaft		1	173	Centric Shaft		2
128A	Shaft		1	174	Ball Bearing	#608ZZ	8
129	Ball Bearing	#6006ZZ	2	175	E Ring	E7	4
130	Idle Flywheel		1	176	Eccentric Shaft		2
131	Washer		1	177	Front Ball Bearing Seat		1
132	Spring Washer	M10	1	178	Front Blade Guard		1
133	Hex. Cap Bolt	M10x25	1	179	Hex. Socket Cap Screw	M6x8	1
134A	Blade		1	180	Hex. Socket Cap Screw	M8x20	2
135	Knob Bolt	M6x10	4	181	Ball Bearing	#608ZZ	2
136A	Blade Cover		1	182	Flat Washer	M8x18x2	2
137	Round Head Screw	M4x8	2	183	Pipe Fitting	1/4Px5/16	2
138-1	Nut	M4	2	184	Nut	M8	4
139	Hex. Cap Bolt	M10x25	1	185	Spring Washer	M8	4
140	Spring Washer	M10	1	186	Rear Ball Bearing Seat		1
141	Washer		1	188	Hex. Socket Cap Screw	M8x25	2
142	Drive Flywheel		1	189	Rear Blade Guard		1
143	Hex. Socket Cap Screw	M8x35	4	190	Round Head Screw	M6x8	2
144	Spring Washer	M8	4				

951021

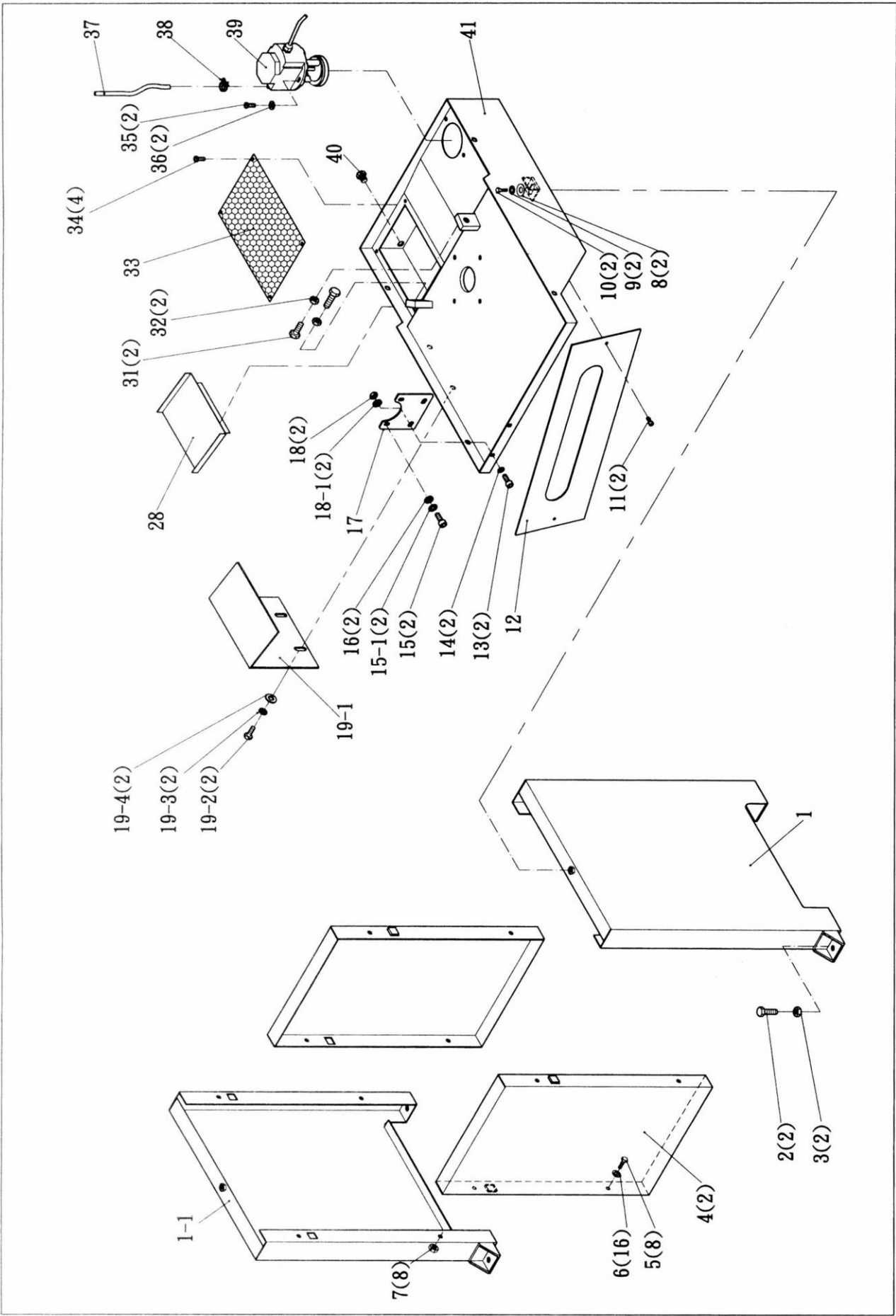

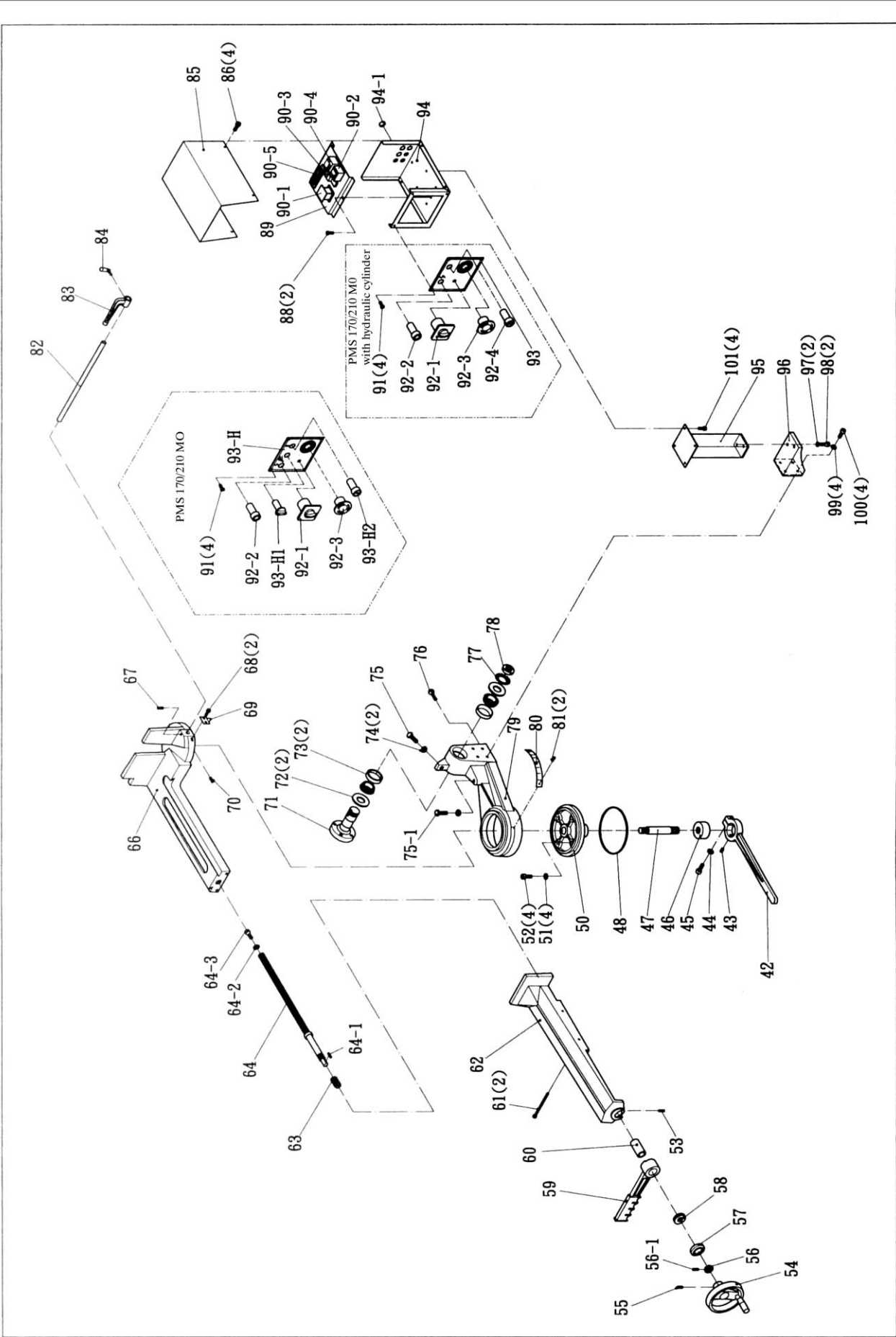



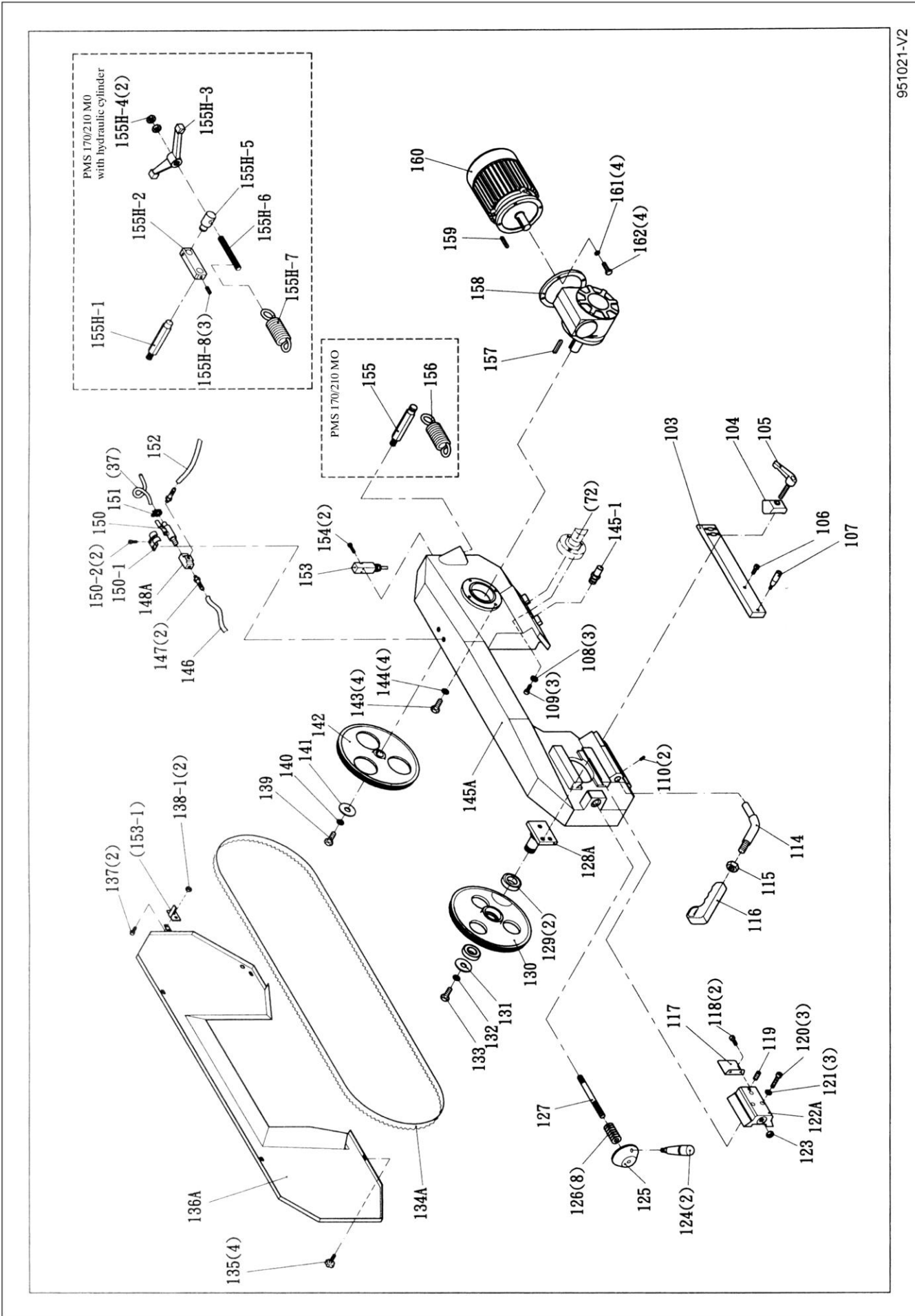

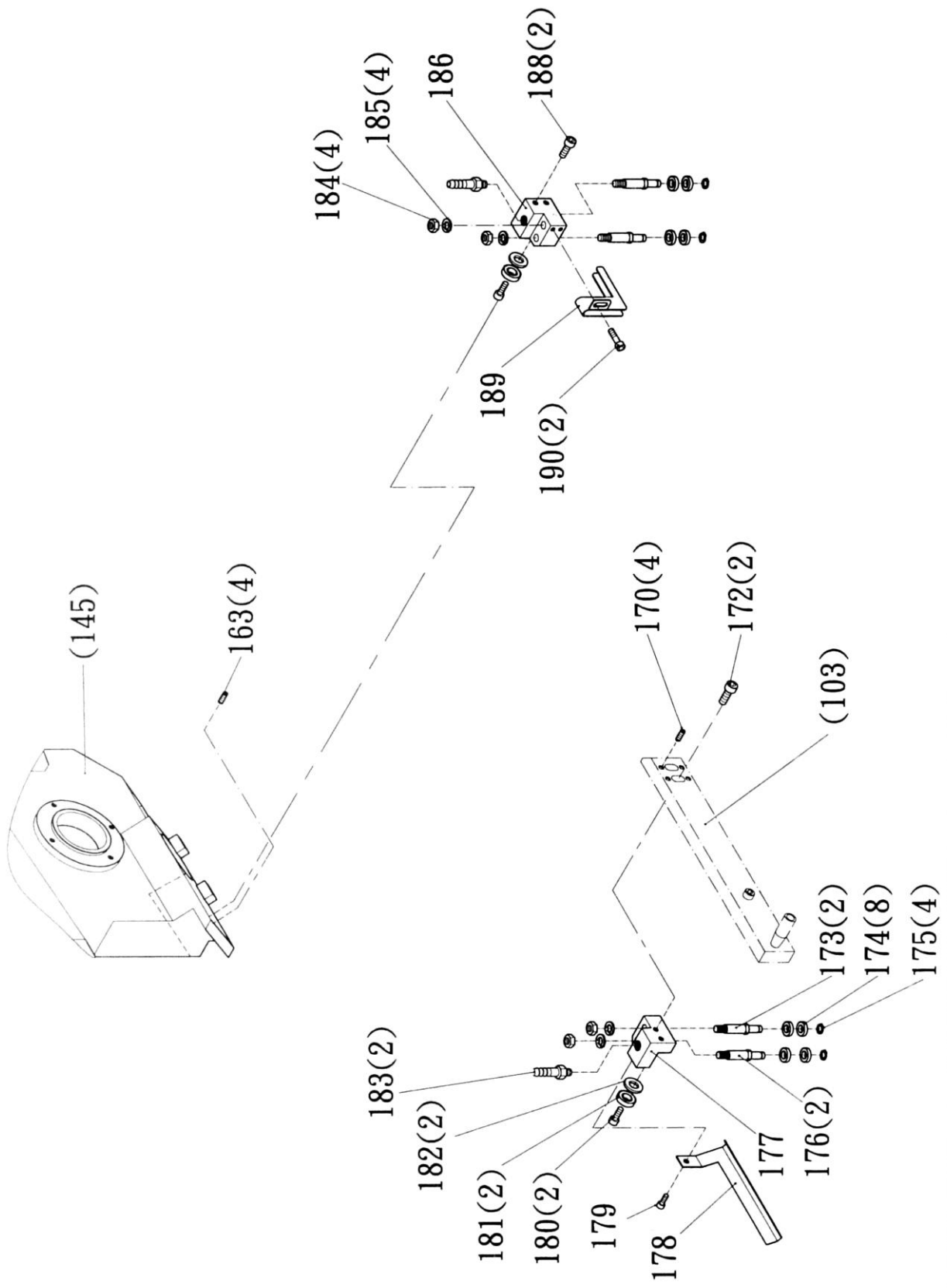

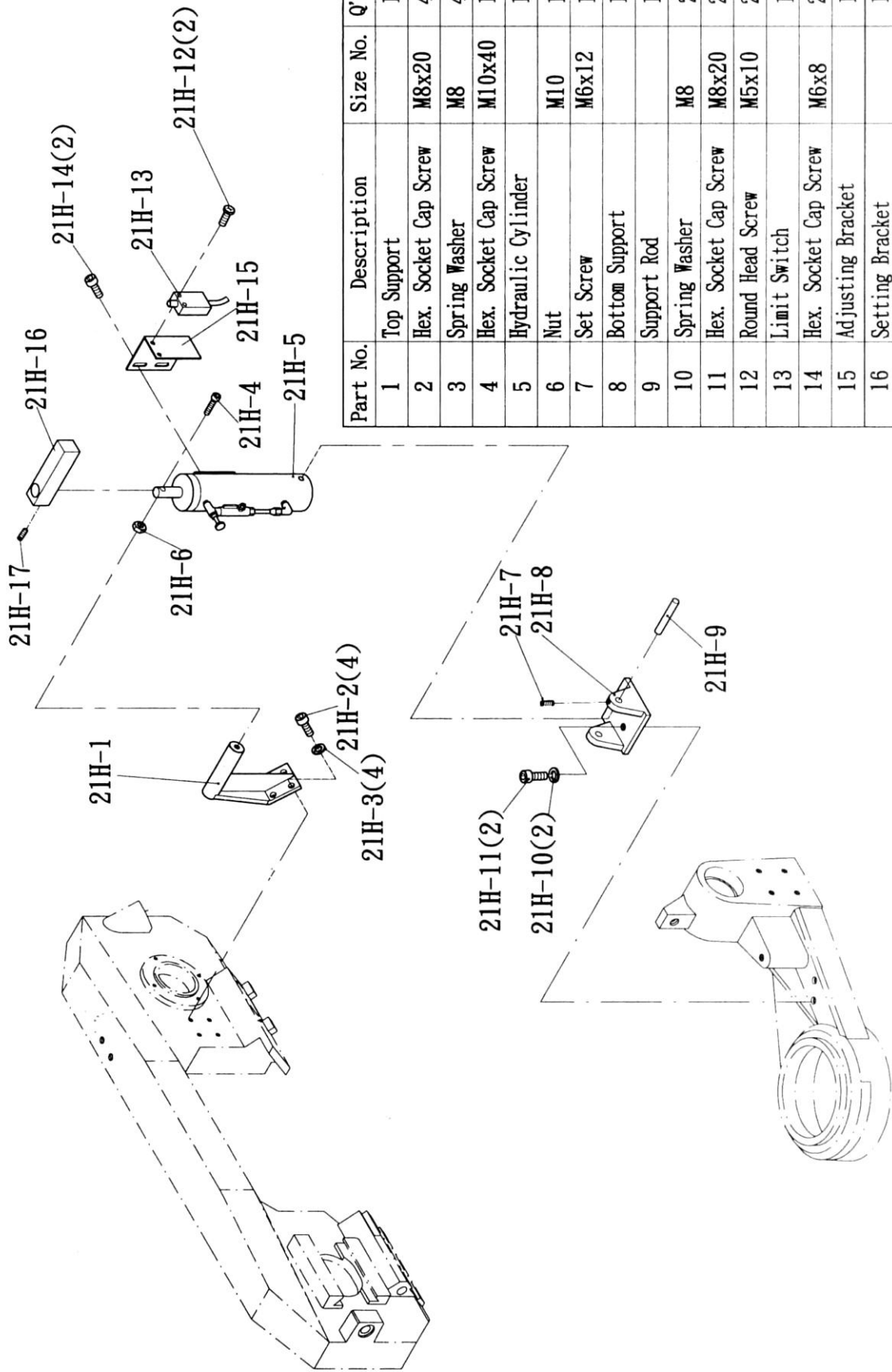

Part No.	Description	Size No.	Q'ty
1	Top Support		1
2	Hex. Socket Cap Screw	M8x20	4
3	Spring Washer	M8	4
4	Hex. Socket Cap Screw	M10x40	1
5	Hydraulic Cylinder		1
6	Nut	M10	1
7	Set Screw	M6x12	1
8	Bottom Support		1
9	Support Rod		1
10	Spring Washer	M8	2
11	Hex. Socket Cap Screw	M8x20	2
12	Round Head Screw	M5x10	2
13	Limit Switch		1
14	Hex. Socket Cap Screw	M6x8	2
15	Adjusting Bracket		1
16	Setting Bracket		1
17	Set Screw	M6x12	1