

651



neu

MODEL NO	F1 (N)	F2 (N)	F3 (N)	F4 (N)	Fi (N)	Vn (dm ³)	AÇI (ANGLE) (± 5°)	AĞIRLIK (WEIGHT) (gr)	BAR
651-2	1200	700	1400	925	300	0.25	90°	570	6
651-3	2000	1400	2500	1560	500	0.51	90°	910	6
651-4	3000	2000	3300	2200	750	1.04	90°	1945	6
651-5	4500	2500	5000	3000	1100	2	90°	3678	6

F1 - F2 : BASKI KUVVETİ (EXERTING FORCE) , F3 - F4 : TUTMA KAPASİTESİ (HOLDING CAPACITY) , Fi : UYGULAMA KUVVETİ (APPLIED FORCE)

Vn , 6 BAR BASINÇTA ÇİFT HAREKET İÇİN HAVA TÜKETİM MİKTARIDIR (Vn , AIR CONSUMPTION PER DOUBLE STROKE IN dm³ AT 6 BAR)

Ayak Tipi: Dik Tabanlı
Body Mounting Base: Vertical

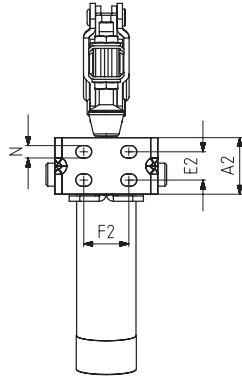
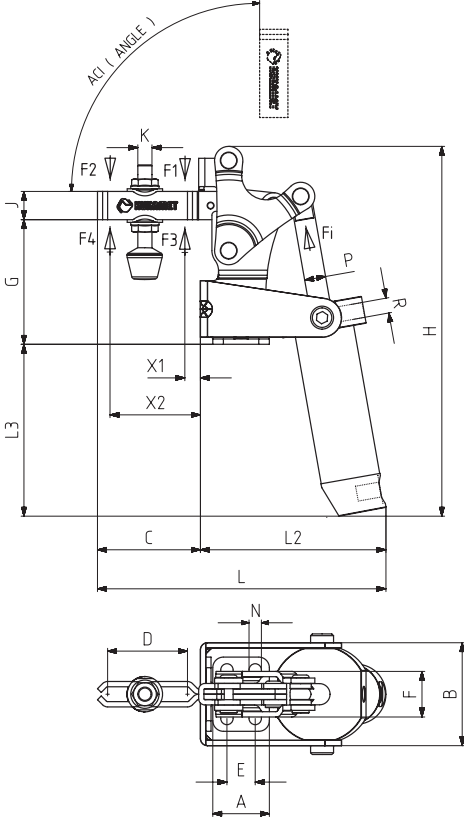
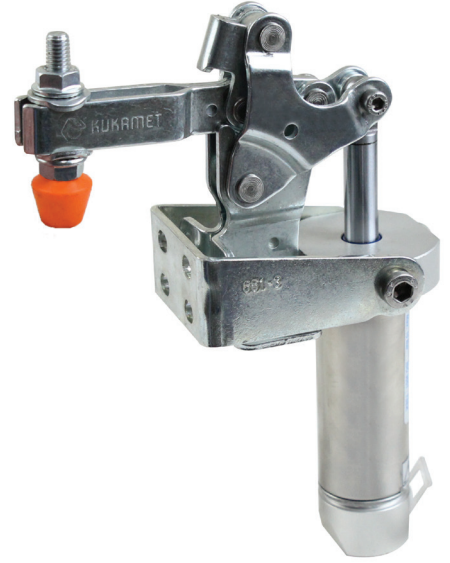

MODEL NO : 651-2

MODEL NO : 651-3

MODEL NO : 651-4

MODEL NO : 651-5

Pistonlar çift etkili, manyetik ve yastıklıdır.
Pneumatic cylinders are double acting, magnetic and cushioning.



MODEL NO	A	A2	B	C	D	E	E2	F	F2	G	H	J	K	L	L2	L3	N	X1	X2	P	R	PİSTON Ø
651-2	26	26	51	54	42	12,5	12,5	25 - 29	25 - 29	65	180	13	M6	146	92	82	6x8	12	42	Ø 10	G1/8	25
651-3	32	32	60	57	42	16	16	23,5 - 27,5	23,5 - 27,5	70,5	210	16	M8	164	106	98	7x9	15	42	Ø 12	G1/8	32
651-4	50	50	79	89	67	32	32	45	45	100	255	20	M10	230	141	101	9	22	70	Ø 16	G1/8	40
651-5	65	65	91	113	94	41,5	41,5	57	57	130	311	25	M12	286	172	114	11	25	91	Ø 20	G1/8	50