

FORCELLE

forks

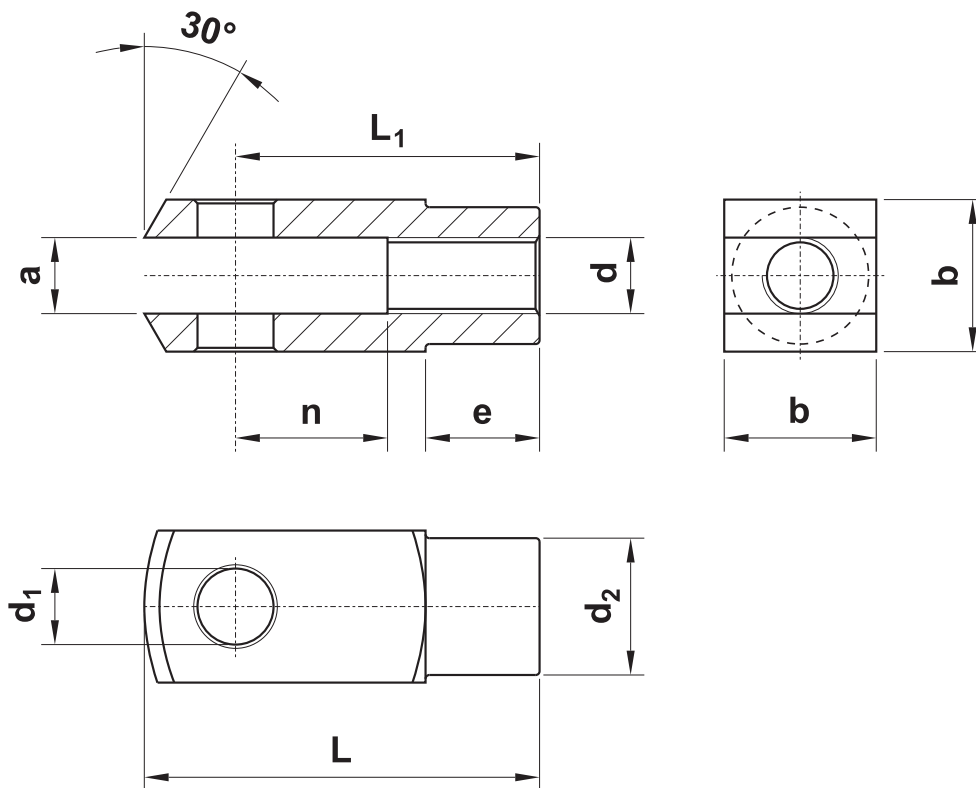

sigla part number	per alesaggi for bores	d	a	b	d ₁	d ₂	e	L	L ₁	n	fornita con it is supplied with
FR8C10	8-10	M4x0.7	4	8	ø4	ø8	6	21	16	8	clip
FR12C16	12-16	M6x1	6	12	ø6	ø10	9	31	24	12	clip
FRC20	20	M8x1.25	8	16	ø8	ø14	12	42	32	16	clip
FR25C32	25-32	M10x1.25	10	20	ø10	ø18	15	52	40	20	clip
FRC40	40	M12x1.25	12	24	ø12	ø20	18	62	48	24	clip
FR50C63	50-63	M16x1.5	16	32	ø16	ø26	24	83	64	32	clip
FR80C100	80-100	M20x1.5	20	40	ø20	ø34	30	105	80	40	clip
FRC125	125	M27x2	30	55	ø30	ø48	38	148	110	54	perno (pin)
FR160C200	160-200	M36x2	35	70	ø35	ø60	40	188	144	72	perno (pin)
FRC250	250	M42x2	40	85	ø40	ø70	63.5	232	168	84	perno (pin)

CLIPS PER FORCELLE

clips for forks

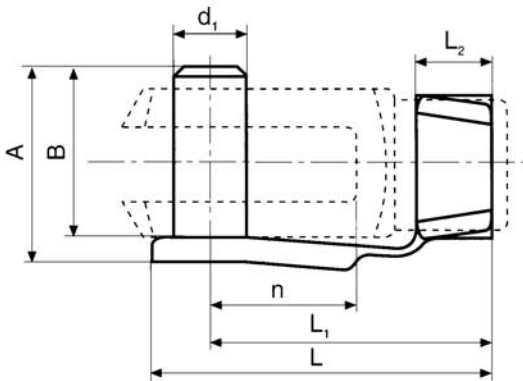

codice code	usata per forcella it is used for fork	d ₁	n	A	B	L	L ₁	L ₂
26.119.0	M4x0.7	4	8	11	9	19	15	5
26.120.0	M6x1	6	12	16	14	28	23	6
26.121.0	M8x1.25	8	16	22	19	37	31	8
26.122.0	M10x1.25	10	20	26	23	46	39	10
26.123.0	M12x1.25	12	24	32	28	55	47	12
26.124.0	M16x1.5	16	32	40	36	72	62	14
26.125.0	M20x1.5	20	40	48	44	88	72	16

PERNI PER FORCELLE

pins for forks

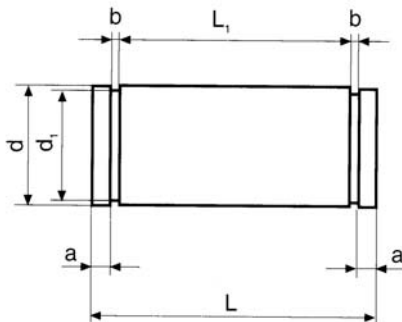

usato per forcella it is used for fork	d	L	d ₁	L ₁	a	b
M27x2	30	65	28.6	55	3.4	1.6
M36x2	35	84	33.4	70	5.4	1.6

DADI PER STELO

nuts for piston-rod



sigla part number	STANDARD	codice code	sigla part number	INOX	codice code	per alesaggio for bore	filetto thread	chiave key
DSMC8-10		26.196.2				8-10	M4x0.7	7
DSMC12-16		26.197.2				12-16	M6x1	10
DSMC20		26.198.2				20	M8x1.25	13
DSIS032		21.750.0	DSIS032X		21.757.0	25-32	M10x1.25	17
DSIS040		21.751.0	DSIS040X		21.758.0	40	M12x1.25	19
DSIS05063		21.752.0	DSIS05063X		21.759.0	50-63	M16x1.5	24
DSIS080100		21.753.0	DSIS080100X		21.760.0	80-100	M20x1.5	30
DSIS125		21.754.0	DSIS125X		21.761.0	125	M27x2	41
DSIS160200		21.755.0	DSIS160200X		21.762.0	160-200	M36x2	55

TESTE A SNODO

jointing balls

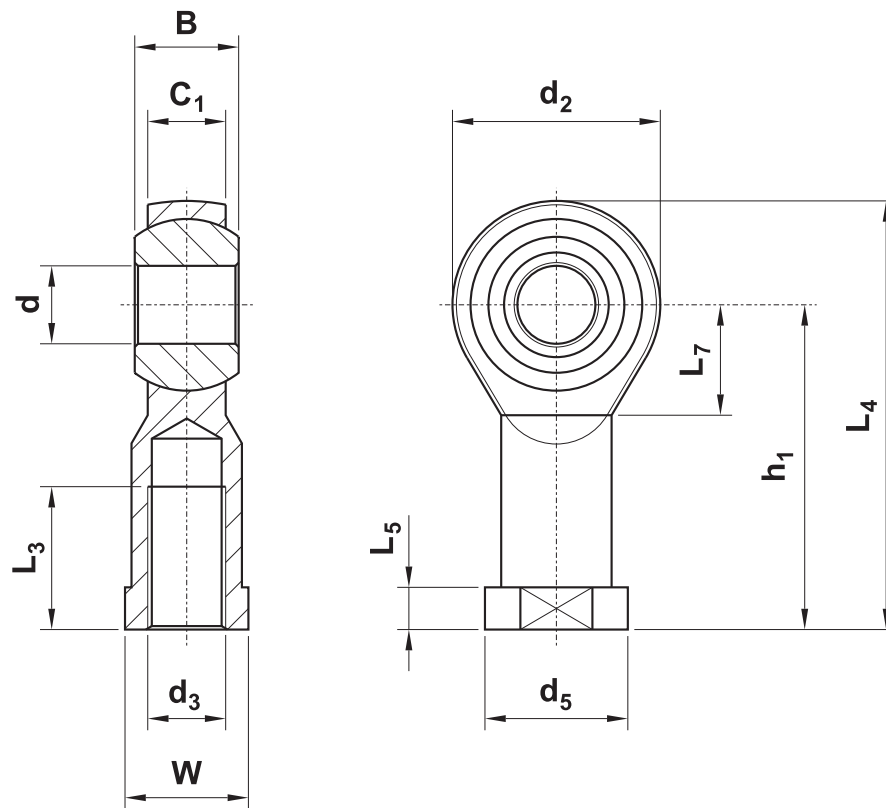

sigla part nr.	STANDARD	sigla part nr.	INOX	per alesaggi for bores	d ₃	d	B	C ₁	d ₂	d ₅	h ₁	L ₃	L ₄	L ₅	L ₇	W
TS8T10		TS8T10X		8-10	M4x0.7	ø5	8	6	18	ø11	27	10	36	4	10	9
TS12T16		TS12T16X		12-16	M6x1	ø6	9	6.75	20	ø13	30	12	40	5	11	11
TST20		TST20X		20	M8x1.25	ø8	12	9	24	ø16	36	16	48	5	13	14
TS25T32		TS25T32X		25-32	M10x1.25	ø10	14	10.5	28	ø19	43	20	57	6.5	15	17
TST40		TST40X		40	M12x1.25	ø12	16	12	32	ø22	50	22	66	6.5	17	19
TS50T63		TS50T63X		50-63	M16x1.5	ø16	21	15	42	ø27	64	28	85	8	23	22
TS80T100		TS80T100X		80-100	M20x1.5	ø20	25	18	50	ø34	77	33	102	10	27	30
TST125		TST125X		125	M27x2	ø30	37	25	70	ø50	110	51	145	15	36	41
TS160T200		TS160T200X		160-200	M36x2	ø35	43	28	80	ø58	125	56	165	17	41	50

SNODI AUTOALLINEANTI

self-aligning joints

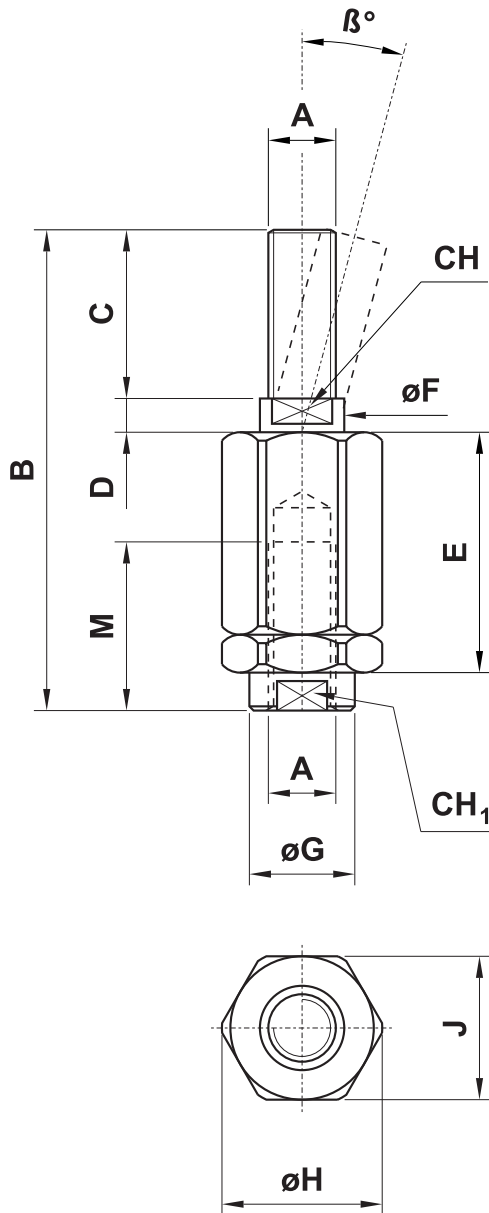

6

sigla part number	per alesaggi for bores	A	B	C	D	E	F	G	H	J	M	CH	β°	CH ₁
SN12D16	12-16	M6x1	35	10	3.5	17.5	6	8.5	14.5	13	10	5	10	7
SND20	20	M8x1.25	57	20	4	28.5	8	12.5	19	17	20	7	10	11
SN25D32	25-32	M10x1.25	71	20	5	35	14	22	32	30	20	12	10	19
SND40	40	M12x1.25	75	24	5	35	14	22	32	30	20	12	10	19
SN50D63	50-63	M16x1.5	103	32	8	54	22	32	45	41	32	20	10	30
SN80D100	80-100	M20x1.5	119	40	8	54	22	32	45	41	40	20	10	30
SND125	125	M27x2	147	54	10	60	32	57	70	65	48	24	8	54

SOFFIETTI DI PROTEZIONE PER STELO

piston rod protection covers

Soffietto di protezione per stelo cilindri ISO 15552, realizzato in stoffa cucita a doppio strato, resistente a polvere, acqua e olio. Colore: blu.

Il soffietto deve essere fissato al cilindro mediante due fascette (non fornite insieme al soffietto).

Piston rod protection cover for ISO 15552 cylinders, in double-sided hyped-up cloth (fabric). Water, oil and dust resistant. Colour: blue.

The protection cover must be fixed on the piston rod by two clamps, not provided with the protection cover.

SO	A	1	0
----	---	---	---

identificazione taglia
size identification

numero spire
number of windings

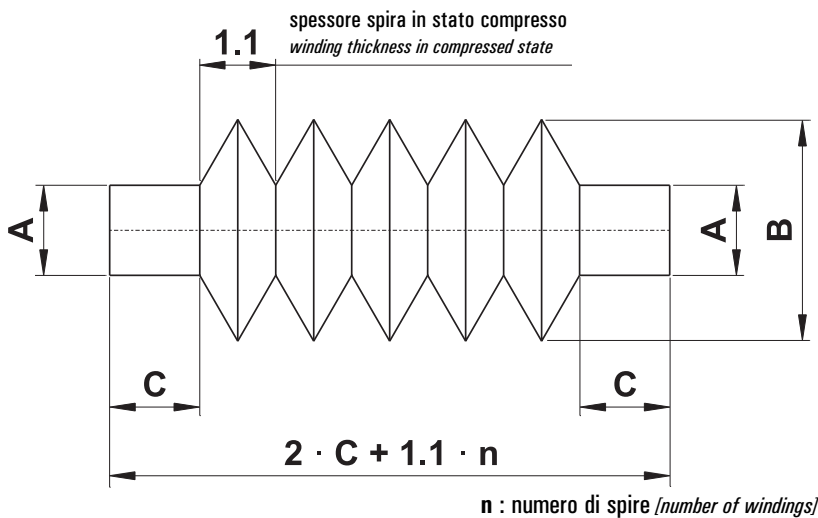

per cilindro ϕ <i>for cylinder ϕ</i>	A	B	C	spire per 100 mm di corsa <i>number of windings for 100 mm stroke</i>	identif. taglia <i>size identification</i>
32; 40	30	60	36	10	A
50; 63; 80	40	80	46	8	B
100; 125	55	130	40	4	C
160; 200	70	155	55	3	D
250; 320	110	180	60	3	E

alesaggio <i>bore</i>	corsa massima (mm) <i>maximum stroke (mm)</i>	nr. corrispondente di spire <i>corresponding number of windings</i>
32	90	9
40	90	9
50	130	11
63	130	11
80	140	12
100	330	14
125	550	22
160	870	27
200	1170	36

Corsa massima del cilindro oltre la quale si consiglia di aumentare la quota D della sporgenza stelo (vedi pag. 523-525) di 1.1 mm per ogni spira del soffietto.

Esempio: per un cilindro alesaggio 80 corsa 300 sono necessarie 24 spire. Occorre dunque prolungare lo stelo di $(24-12) \times 1.1 \text{ mm} = 13.2 \text{ mm}$. Il cilindro con stelo prolungato deve essere ordinato come speciale all'ufficio commerciale.

If the cylinder stroke is longer than the value in this table, we advise to increase the dimension D of the piston rod length (refer to pages 523-525) by 1.1 mm for each winding.

Example: a cylinder bore 80 and stroke 300 needs 24 windings. It is necessary to increase the piston rod length by $(24-12) \times 1.1 \text{ mm} = 13.2 \text{ mm}$. The cylinder with longer piston rod must be ordered as special (please contact the commercial office).