

Shift Chain

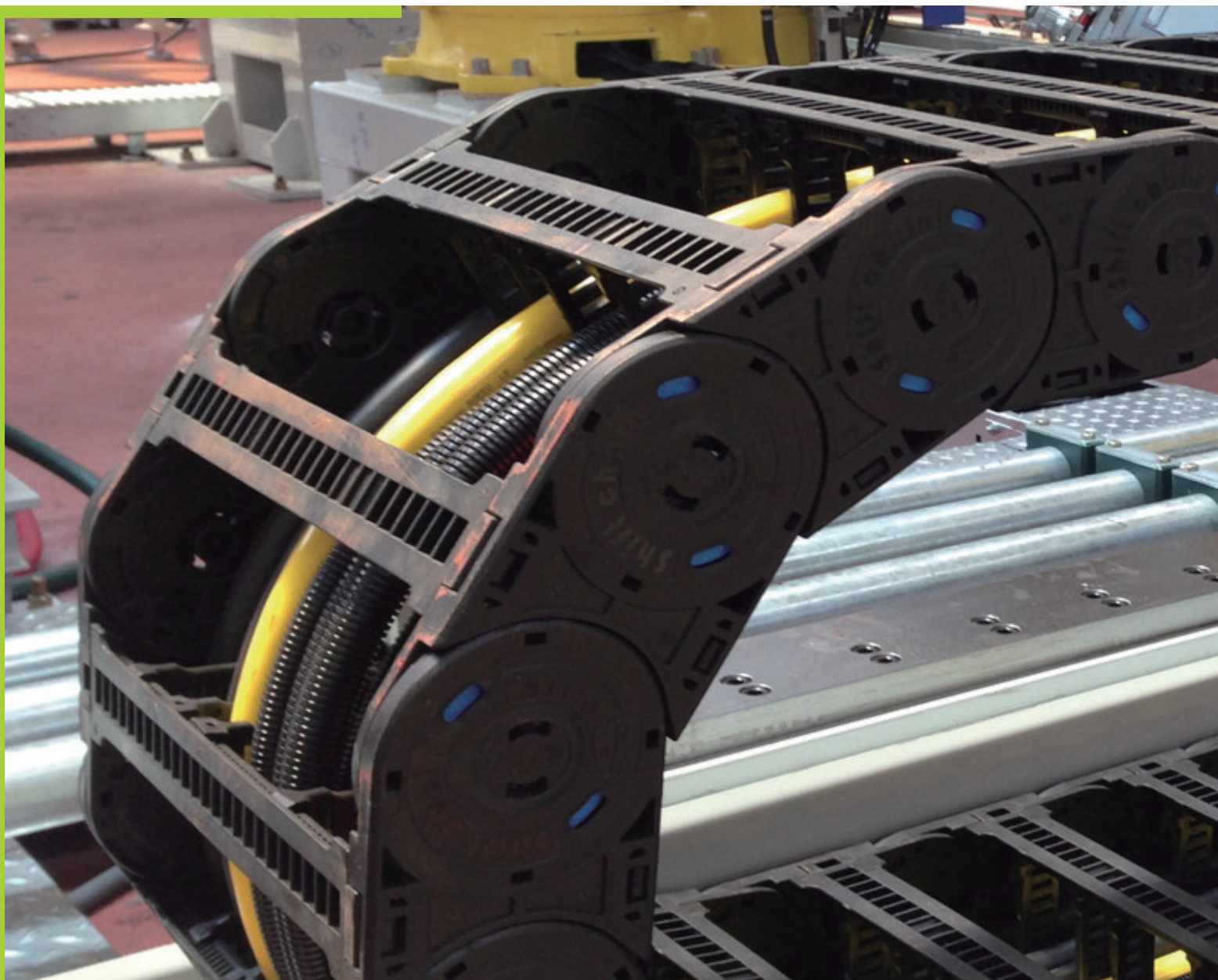

Shift chain®

ST - N : Normal type

▶ST044N	C-9
▶ST055N	C-11
▶ST072N	C-13
▶ST095N	C-15
▶ST120N	C-17
▶ST150N	C-19

ST - E : Enclosed type

▶ST044E	C-27
▶ST055E	C-29
▶ST072E	C-31
▶ST095E	C-33
▶ST120E	C-35
▶ST150E	C-37

ST - S : Skid type

▶ST044S	C-43
---------	------



ST - ES :
Enclosed Skid type

- | | |
|----------|------|
| ▶ST044ES | C-51 |
| ▶ST072ES | C-53 |
| ▶ST095ES | C-55 |
| ▶ST120ES | C-57 |

ST - RS :
Roller Skid type

- | | |
|----------|------|
| ▶ST044RS | C-65 |
| ▶ST072RS | C-67 |
| ▶ST095RS | C-69 |
| ▶ST120RS | C-71 |
| ▶ST150RS | C-73 |

ST - ERS :
Enclosed Roller Skid type

- | | |
|-----------|------|
| ▶ST044ERS | C-81 |
| ▶ST072ERS | C-83 |
| ▶ST095ERS | C-85 |
| ▶ST120ERS | C-87 |

Shift Chain - Normal type

» General information

Item	Value
Material	CPS-Amid(PA6+GF), RoHs
Speed	3m/s
Acceleration	10m/s ²
Temperature	-30°C ~+130°C
Special production	ESD, UV
Certificate	CE, ATEX(Ex)

» Calculation table

Item	Value
Length of Cable Chain	$L = \frac{1}{2} \times LS + LP$
Bending Radius	
The biggest Cable inserted	Multiply 8~10 and the biggest cable
The biggest Hydraulic Hose inserted	Multiply 15~20 and the biggest hose

» Dimension table

Shift Chain N Type	Pitch	Bending Radius (R)	Weight kg/m	Speed m/s	Temperature °C	Size				Frame type	Section-composition
						A	B	C	D		
ST 044N	44	50, 70, 90, 120, 150	0.93	3	-30 ~ +130	56	35	38	26		
			0.97			71	50				
			1.00			76	55				
			1.06			96	75				
			1.17			121	100				
			1.30			146	125				
			1.43			171	150				
			1.78			196	175				
			1.94			221	200				
			ST 055N			55	65, 75, 100, 125, 150, 200		1.12		
1.15	71	50									
1.18	76	55									
1.23	96	75									
1.31	121	100									
1.41	146	125									
1.51	171	150									
1.78	196	175									
1.92	221	200									
ST 072N	72	72, 100, 120, 145, 200, 250, 300		2.10	3			-30 ~ +130	82	50	66
			2.20	107		75					
			2.30	132		100					
			2.43	157		125					
			2.51	172		140					
			2.56	182		150					
			2.62	197		165					
			2.66	207		175					
			2.93	222		190					
			3.11	232		200					
3.21	272	240									
3.24	282	250									
3.60	332	300									
ST 095N	95	135, 150, 200, 230, 280, 400	3.11	3	-30 ~ +130	113	75	82	56		
			3.17			138	100				
			3.37			163	125				
			3.49			188	150				
			3.60			213	175				
			3.71			228	190				
			3.79			238	200				
			4.00			278	240				
			4.05			288	250				
			4.31			338	300				
4.69	388	350									
5.05	438	400									
ST 120N	120	180, 200, 250, 300, 350, 400, 500	4.41	3	-30 ~ +130	117	75	108	78		
			4.53			142	100				
			4.61			157	115				
			4.67			167	125				
			4.78			192	150				
			4.93			217	175				
			5.17			242	200				
			5.41			282	240				
			5.47			292	250				
			5.80			332	290				
5.88	342	300									
6.30	392	350									
6.73	442	400									
7.07	492	450									
7.30	542	500									
8.13	592	550									
8.30	642	600									
ST 150N	150	205, 305, 405, 505, 605	5.85	3	-30 ~ +130	121	75	140	110		
			5.96			146	100				
			6.03			161	115				
			6.08			171	125				
			6.18			196	150				
			6.30			221	175				
			6.51			246	200				
			6.72			286	240				
			6.78			296	250				
			7.06			336	290				
7.14	346	300									
7.51	396	350									
7.88	446	400									
8.18	496	450									
8.37	546	500									
9.11	596	550									
9.26	646	600									

(Dimensions in mm)

» Ordering

ST 044N, 100, R120 / F - 1500L : 10ST

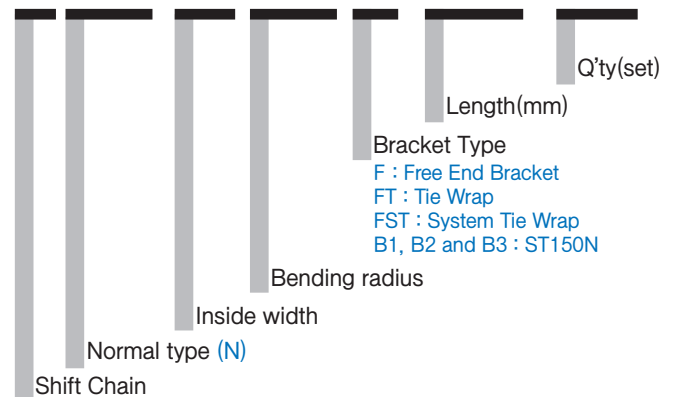

» Bracket type

- ST044, ST055, ST072, ST095, ST120

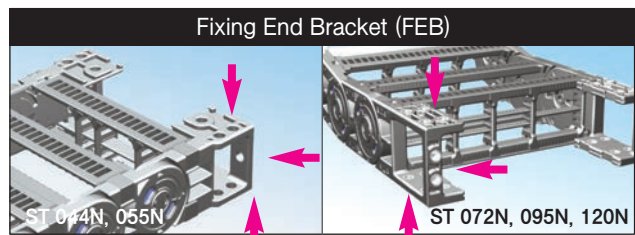

- ST150

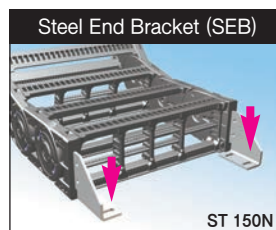

For ST150N, its end parts of cable chain being fixed are used with steel bracket, and it is possible to be installed B1, B2, B3 types of brackets.

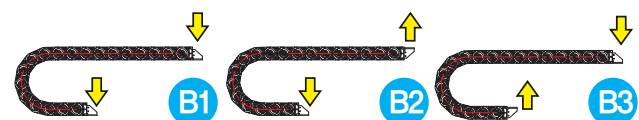

» Application of Shift Chain

- Shift Chain can be applied to all kinds of machine tools and factory lines.

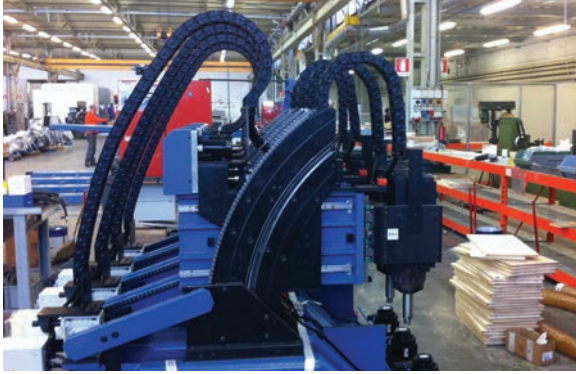

▶ **ST 044N** **Application:**
Machine tool
Location:
Italy
Remark:
Verious stroke and direction



▶ **ST 120N** **Application:**
Robot Carriage line
Location:
China
Remark:
Stroke 3 meters

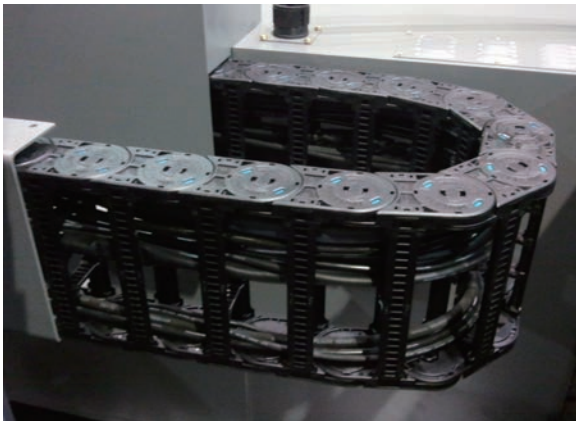

▶ **ST 055N** **Application:**
Machine tool
Location:
Japan
Remark:
Side mounting



▶ **ST 095N**
Application:
Steel manufacturing line
Location:
Korea
Remark:
Verious stroke and direction



▶ **ST 072N**
Application:
Nylon Cloth cutting machine
Location:
Italy
Remark:
Stroke 2,5 meters

» Customized Shift Chain

Shift Chain is designed to be able to move in upper, lower and diagonal directions according to machine's movement. Changing a different Bending Radius value at the point that the chain movement turn other sides can create the bending radius or the reverse bending radius for the direction that you need, so the machine can move in zigzag direction. Shift Chain can be used for special usage such as a zigzag chain, and has an excellent installation scalability in any hazard environment for cable protection with the general chain. If you need special chain installation, please contact our R&D center.

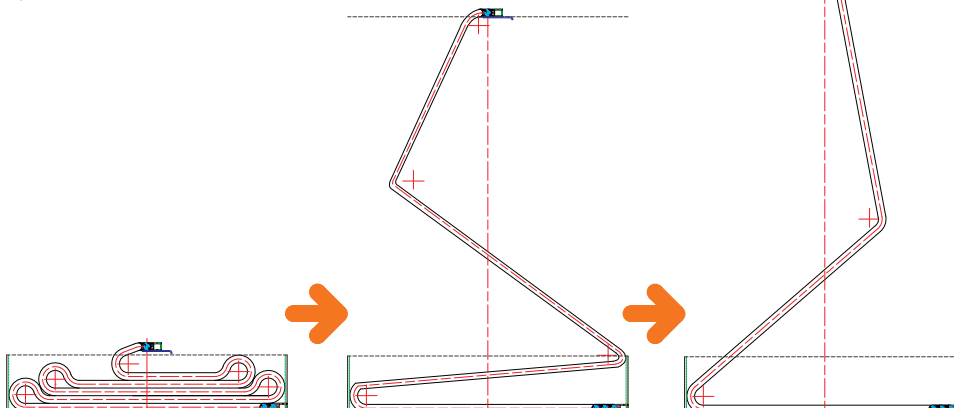

Shift Chain - Normal type

» Part of Shift Chain Normal type

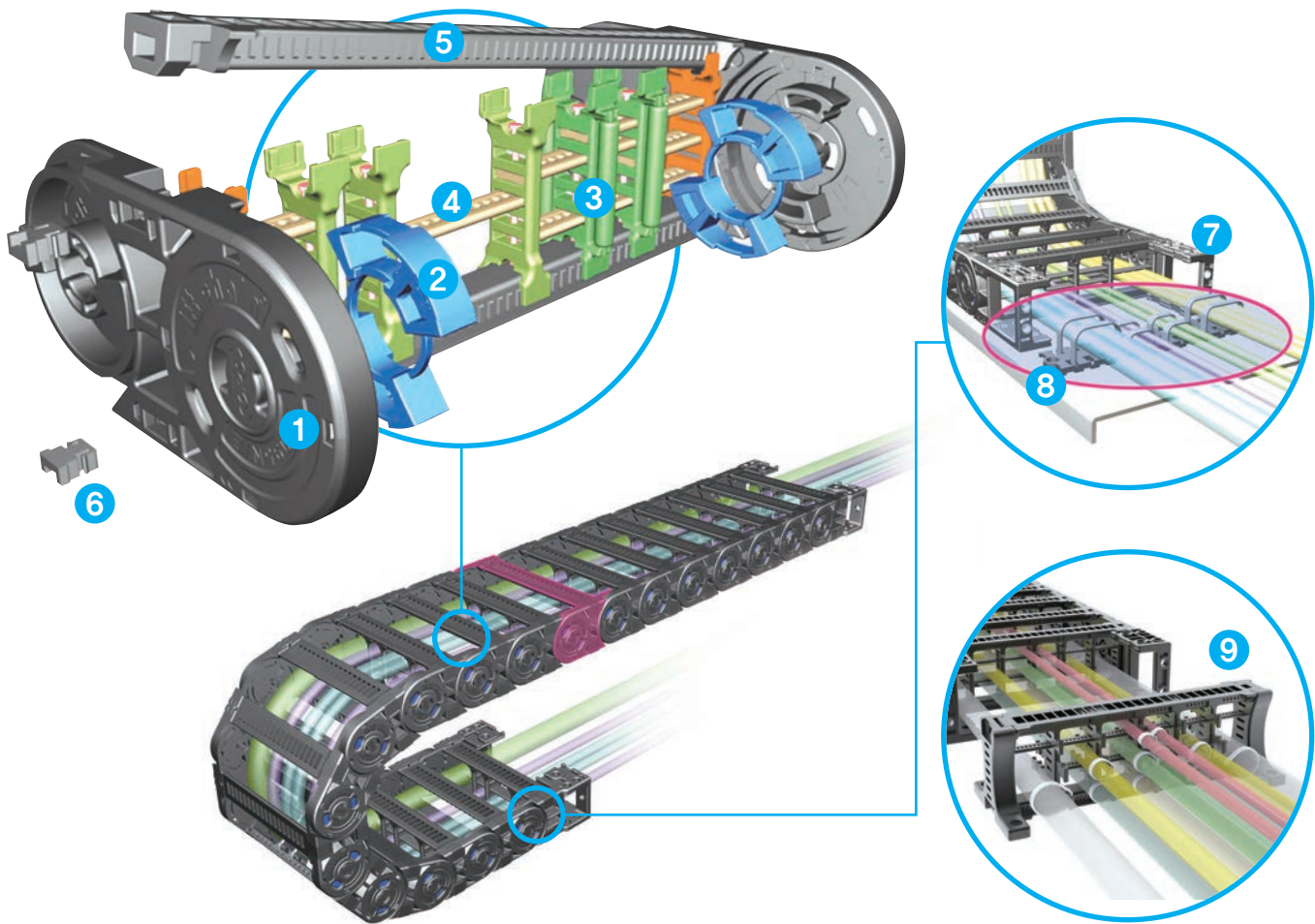

1 Side Band (SB)

A unit that connects each side band and between them BR is inserted to strengthen clamping force.

2 Bending Radius Unit (BR)

A unit that inserted between each side band. There are 6 supporting points to create durability.

3 Divider (DV-S, M, R, T)

A unit that divides inserted cables horizontally.

4 Separator (SP)

A unit that divides inserted cables vertically to prevent twisting and breaking problem.

5 Frame (Hinged Type) (FR)

Hinged-type frame, open one side, supports connection of both side of side band and have tongue and groove system plate to secure the position of the divider on the frame.

6 Frame Pin (FP)

The connecting pin for preventing the breakaway of Frame connected at Side Band, combining and fixing the Frame and Side Band. For Shift chain(ST)072N, 092N, 120N, 150N type, one side of the frame is fixed by inserting a fixing pin to prevent frame open, which caused by any external impact. Also, in case of ST044N, ST055N type, an open side of the frame is fixed by Hook-type frame.

7 Free End Bracket (FEB)

A unit that connects at last side band (left&right). It can be fixed stronger using steel washers.

8 Tie Wrap (TW)

A unit that ties cables to maintain straightness of them. It can be assembled to bracket directly or installed separately from bracket.

9 System Tie Wrap (STW)

System-Tie Wrap has to be assembled on fixing and moving point of bracket and can be assembled without any tie wrap plate. This tie wrap is used to stay the cables on several floors prevent the cables from being twisted and it can also be assemble without any tools or bolt. This tie wrap has two types, one is to assemble inside bracket the other one is outside.

» Assembly procedure of Shift Chain Normal type

The assembling process of Shift Chain N-Type is like below and users must use rubber hammer with careful combination of Divider and Separator. Be careful of different assembling process depending on product specification such as ST044N, 055N Type, ST072N, 095N, 120N Type, ST150N Type etc.

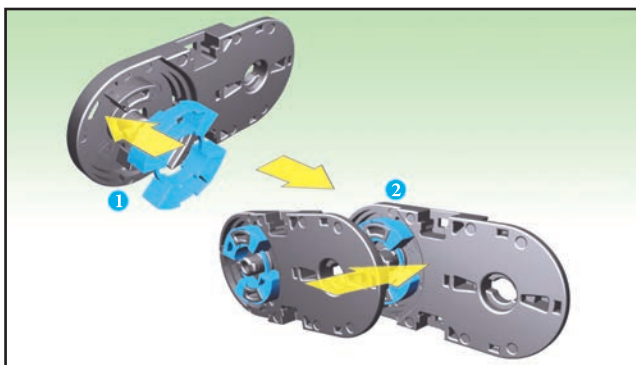

1 Insert BR unit to each side band, connect the side bands as many as you need, then do the same process to the other side of side band.

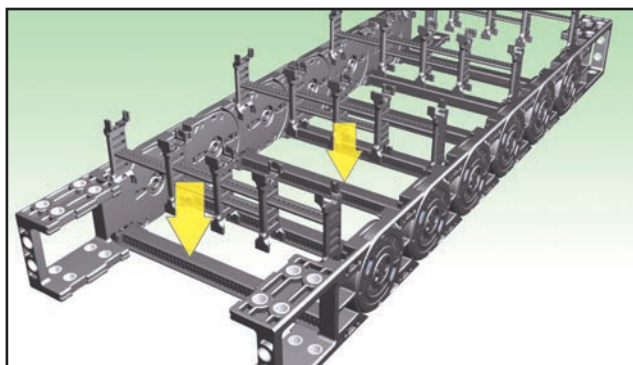

5 Fix the separator and divider patterns to the bottom-side frames as needed.

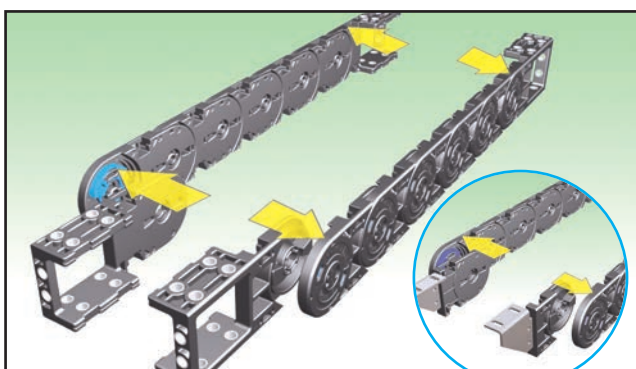

2 Assemble the end brackets on both ends using the same method.

For ST150N, assemble steel brackets on both ends.

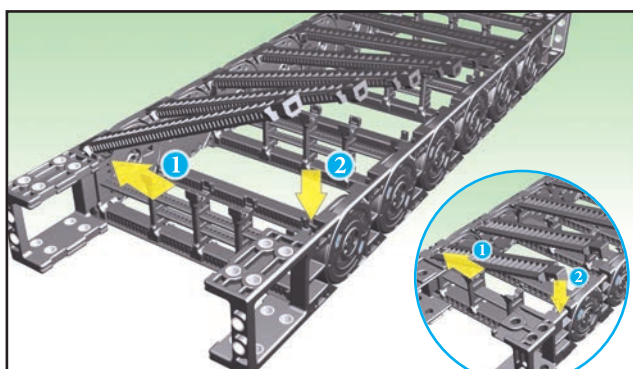

6 Attach frames to one side groove on the side band, and then the other side.

ST044N, 055N frame type.

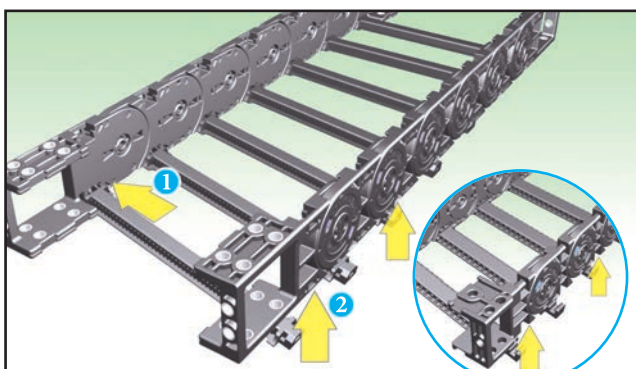

3 Attach frames to one side groove on the side band, and then the other side.

ST 044N, 055N are Hinge Type or Hook Type without frame pin.

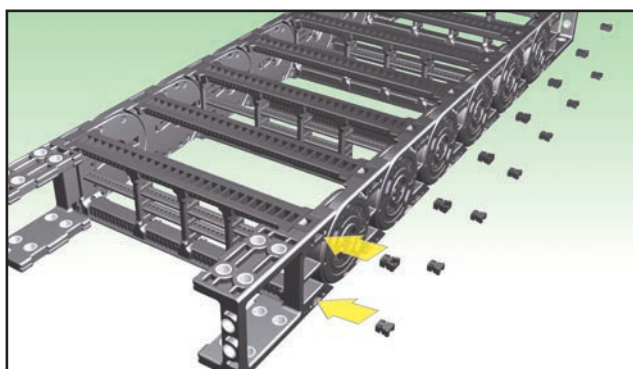

7 Insert frame pins to secure the frames and complete carrier. (ST072N, 095N, 120N, 150N are applied with frame pin, and ST044N, 055N are Hinge Type or Hook Type without frame pin.)

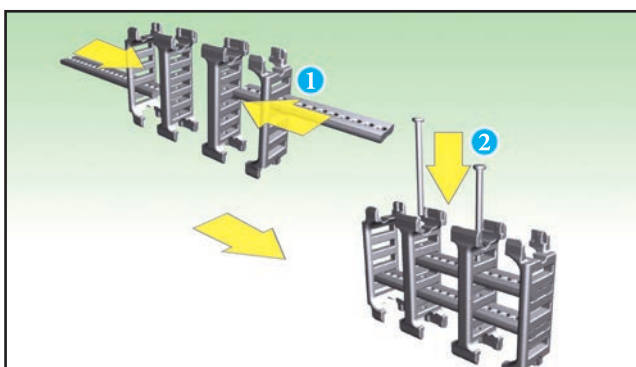

4 For ST072N, 095N, 120N, and 150N, connect the pin of separator in hole of divider after inserting separator in hole of divider. For ST044N and ST055N, separator fixing pins are not used.

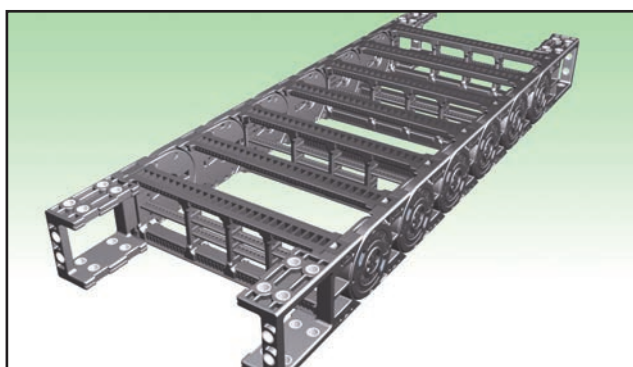

8 Assembled Shift Chain N-Type is assembled.

Shift Chain - Normal type

» Part list of Shift Chain Normal type

- Composition of Cable chain(Standard)
= Side band(RH) + Frame + Side band(LH) + Bending radius Unit + Free end bracket
- M divider(normal divider) should be applied every second frames to make a section composition.
- ※ Please refer to below part list and description to understand composition of cable chain.

Model	Classification	Part number	Description
ST044N	SIDE BAND	ST-SB044N/E(LH) ST-SB044N/E(RH)	Left side band of ST044N Right side band of ST044N
	BENDING RADIUS	ST-BR044.R50,70,90,120,150	Bending radius unit for side band
	FRAME	sb-FR/M,35 sb-FR/M,50 sb-FR/M,55 sb-FR/M,75 sb-FR/M,100 sb-FR/M,125 sb-FR/M,150 sb-FR/M,175 sb-FR/M,200	Frame, 35mm Frame, 50mm Frame, 55mm Frame, 75mm Frame, 100mm Frame, 125mm Frame, 150mm Frame, 175mm Frame, 200mm
	FREE END BRACKET	ST-FEB044N/S	End bracket of ST044N
	DIVIDER	sb-DV028/M sb-DV028/S	Normal divider To fix separstors at the both side section
	SEPARATOR	S-SP/M,35 S-SP/M,50 S-SP/M,75 S-SP/M,100 S-SP/M,125 S-SP/M,150 S-SP/M,175 S-SP/M,200	Separator, 35mm Separator, 50mm Separator, 75mm Separator, 100mm Separator, 125mm Separator, 150mm Separator, 175mm Separator, 200mm
	TIE WRAP	S-TW036/025CR,35 S-TW036/025CR,55 S-TW036/025CR,75 S-TW036/025CR,100 S-TW036/025CR,125	Tie wrap for end bracket to fix cables, 35mm Tie wrap for end bracket to fix cables, 55mm Tie wrap for end bracket to fix cables, 75mm Tie wrap for end bracket to fix cables, 100mm Tie wrap for end bracket to fix cables, 125mm
	SYSTEM TIE WRAP	sb-DV028/W S-TW,EB028	Divider for fixing cables at end bracket System tie wrap to arrange for cables right after moving bracket or fixing bracket

Model	Classification	Part number	Description
ST055N	SIDE BAND	ST-SB055N/E(LH) ST-SB055N/E(RH)	Left side band of ST055N Right side band of ST055N
	BENDING RADIUS	ST-BR055.R65,75,100,125,150,200	Bending radius unit for side band
	FRAME	sb-FR/M,35 sb-FR/M,50 sb-FR/M,55 sb-FR/M,75 sb-FR/M,100 sb-FR/M,125 sb-FR/M,150 sb-FR/M,175 sb-FR/M,200	Frame, 35mm Frame, 50mm Frame, 55mm Frame, 75mm Frame, 100mm Frame, 125mm Frame, 150mm Frame, 175mm Frame, 200mm
	FREE END BRACKET	ST-FEB055N/S	End bracket of ST055N
	DIVIDER	sb-DV035/M sb-DV035/S	Normal divider To fix separstors at the both side section
	SEPARATOR	S-SP/M,35 S-SP/M,50 S-SP/M,55 S-SP/M,75 S-SP/M,100 S-SP/M,125 S-SP/M,150 S-SP/M,175 S-SP/M,200	Separator, 35mm Separator, 50mm Separator, 55mm Separator, 75mm Separator, 100mm Separator, 125mm Separator, 150mm Separator, 175mm Separator, 200mm
	TIE WRAP	S-TW050/035N,50 S-TW050/035N,75 S-TW050/035N,100 S-TW050/035N,125 S-TW050/035N,150 S-TW050/035N,175 S-TW050/035N,200	Tie wrap for end bracket to fix cables, 50mm Tie wrap for end bracket to fix cables, 75mm Tie wrap for end bracket to fix cables, 100mm Tie wrap for end bracket to fix cables, 125mm Tie wrap for end bracket to fix cables, 150mm Tie wrap for end bracket to fix cables, 175mm Tie wrap for end bracket to fix cables, 200mm
	SYSTEM TIE WRAP	sb-DV035/W S-TW,EB035	Divider for fixing cables at end bracket System tie wrap to arrange for cables right after moving bracket or fixing bracket

Model	Classification	Part number	Description
ST072N	SIDE BAND	ST-SB072N/E(LH) ST-SB072N/E(RH)	Left side band of ST072N Right side band of ST072N
	BENDING RADIUS	ST-BR055.R65,75,100,125,150,200	Bending radius unit for side band
	FRAME PIN	S-FP/S1	Frame pin
	FRAME	sb-FR045,50 sb-FR045,75 sb-FR045,100 sb-FR045,125 sb-FR045,140 sb-FR045,150 sb-FR045,165 sb-FR045,175 sb-FR045,190 sb-FR045,200 sb-FR045,240 sb-FR045,250 sb-FR045,300	Frame, 50mm Frame, 75mm Frame, 100mm Frame, 125mm Frame, 140mm Frame, 150mm Frame, 165mm Frame, 175mm Frame, 190mm Frame, 200mm Frame, 240mm Frame, 250mm Frame, 300mm
	FREE END BRACKET	ST-FEB072N/S sb-FEB/WH045	End bracket of ST072N Steel washer for end bracket
	DIVIDER	sb-DV045/M sb-DV045/S sb-DV045/T sb-DV045/TP	Normal divider To fix separstors at the both side section T divider T divider pin
	SEPARATOR	sb-SP/400,400 SP-PIN045	Separator, 400mm Separator pin to fix
	TIE WRAP	S-TW50 S-TW75 S-TW100 S-TW125 S-TW150	Tie wrap for end bracket to fix cables, 50mm Tie wrap for end bracket to fix cables, 75mm Tie wrap for end bracket to fix cables, 100mm Tie wrap for end bracket to fix cables, 125mm Tie wrap for end bracket to fix cables, 150mm
	SYSTEM TIE WRAP	sb-DV045/W S-TW,EB045	Divider for fixing cables at end bracket System tie wrap to arrange for cables right after moving bracket or fixing bracket

Model	Classification	Part number	Description
ST095N	SIDE BAND	ST-SB095N/E(LH) ST-SB095N/E(RH)	Left side band of ST095N Right side band of ST095N
	BENDING RADIUS	ST-BR055,R65,75,100,125,150,200	Bending radius unit for side band
	FRAME PIN	S-FP/S1	Frame Pin
	FRAME	sb-FR060,75	Frame, 75mm
		sb-FR060,100	Frame, 100mm
		sb-FR060,125	Frame, 125mm
		sb-FR060,150	Frame, 150mm
		sb-FR060,175	Frame, 175mm
		sb-FR060,190	Frame, 190mm
		sb-FR060,200	Frame, 200mm
sb-FR060,230		Frame, 230mm	
sb-FR060,250		Frame, 250mm	
sb-FR060,300		Frame, 300mm	
sb-FR060,350	Frame, 350mm		
sb-FR060,400	Frame, 400mm		
FREE END BRACKET	ST-FEB095N/S sb-FEB/WH060	End bracket of ST095N Steel washer for end bracket	
DIVIDER	sb-DV060/M	Normal divider	
	sb-DV060/S	To fix separstors at the both side section	
	sb-DV060/T	T divider	
	sb-DV060/TP	T divider pin	
SEPARATOR	sb-SP/400,400	Separator, 400mm	
	SP-PIN060	Separator pin to fix	
TIE WRAP	S-TW50	Tie wrap for end bracket to fix cables, 50mm	
	S-TW75	Tie wrap for end bracket to fix cables, 75mm	
	S-TW100	Tie wrap for end bracket to fix cables, 100mm	
	S-TW125	Tie wrap for end bracket to fix cables, 125mm	
S-TW150	Tie wrap for end bracket to fix cables, 150mm		
SYSTEM TIE WRAP	sb-DV060/W S-TWEB060	Divider for fixing cables at end bracket System tie wrap to arrange for cables right after moving bracket or fixing bracket	

Model	Classification	Part number	Description
ST120N	SIDE BAND	ST-SB120N/E(LH) ST-SB120N/E(RH)	Left side band of ST120N Right side band of ST120N
	BENDING RADIUS	ST-BR120,R180, 200, 250, 300, 350, 400, 500	Bending radius unit for side band
	FRAME PIN	S-FP/S2	Frame Pin
	FRAME	sb-FR075/100,75	Frame, 75mm
		sb-FR075/100,100	Frame, 100mm
		sb-FR075/100,115	Frame, 115mm
		sb-FR075/100,125	Frame, 125mm
		sb-FR075/100,150	Frame, 150mm
		sb-FR075/100,175	Frame, 175mm
		sb-FR075/100,200	Frame, 200mm
sb-FR075/100,240		Frame, 240mm	
sb-FR075/100,250		Frame, 250mm	
sb-FR075/100,290		Frame, 290mm	
sb-FR075/100,300		Frame, 300mm	
sb-FR075/100,350		Frame, 350mm	
sb-FR075/100,400		Frame, 400mm	
sb-FR075/100,450		Frame, 450mm	
sb-FR075/100,500		Frame, 500mm	
sb-FR075/100,550		Frame, 550mm	
sb-FR075/100,600	Frame, 600mm		
FREE END BRACKET	ST-FEB120N/S sb-FEB/WH075	End bracket of ST120N Steel washer for end bracket	
DIVIDER	sb-DV075/M	Normal divider	
	sb-DV075/S	To fix separstors at the both side section	
	sb-DV075/T	T divider	
	sb-DV075/TP	T divider pin	
SEPARATOR	sb-SP/400,400	Separator, 400mm	
	SP-PIN075	Separator pin to fix	
TIE WRAP	S-TW50	Tie wrap for end bracket to fix cables, 50mm	
	S-TW75	Tie wrap for end bracket to fix cables, 75mm	
	S-TW100	Tie wrap for end bracket to fix cables, 100mm	
	S-TW125	Tie wrap for end bracket to fix cables, 125mm	
S-TW150	Tie wrap for end bracket to fix cables, 150mm		
SYSTEM TIE WRAP	sb-DV075/W S-TWEB075	Divider for fixing cables at end bracket System tie wrap to arrange for cables right after moving bracket or fixing bracket	

Model	Classification	Part number	Description
ST150N	SIDE BAND	ST-SB150N/E(LH) ST-SB150N/E(RH)	Left side band of ST150N Right side band of ST150N
	BENDING RADIUS	ST-BR150,R205,305,405,505,605	Bending radius unit for side band
	FRAME PIN	S-FP/S2	Frame Pin
	FRAME	sb-FR075/100,75	Frame, 75mm
		sb-FR075/100,100	Frame, 100mm
		sb-FR075/100,115	Frame, 115mm
		sb-FR075/100,125	Frame, 125mm
		sb-FR075/100,150	Frame, 150mm
		sb-FR075/100,175	Frame, 175mm
		sb-FR075/100,200	Frame, 200mm
sb-FR075/100,240		Frame, 240mm	
sb-FR075/100,250		Frame, 250mm	
sb-FR075/100,290		Frame, 290mm	
sb-FR075/100,300		Frame, 300mm	
sb-FR075/100,350		Frame, 350mm	
sb-FR075/100,400		Frame, 400mm	
sb-FR075/100,450		Frame, 450mm	
sb-FR075/100,500		Frame, 500mm	
sb-FR075/100,550		Frame, 550mm	
sb-FR075/100,600	Frame, 600mm		
STEEL END BRACKET	ST-SEB150N/B1-B2-B3	Steel end bracket of ST150N	
DIVIDER	sb-DV075/M	Normal divider	
	sb-DV075/S	To fix separstors at the both side section	
	sb-DV075/T	T divider	
	sb-DV075/TP	T divider pin	
SEPARATOR	sb-SP/600,600	Separator, 600mm	
	SP-PIN100	Separator pin to fix	
TIE WRAP	S-TW50	Tie wrap for end bracket to fix cables, 50mm	
	S-TW75	Tie wrap for end bracket to fix cables, 75mm	
	S-TW100	Tie wrap for end bracket to fix cables, 100mm	
	S-TW125	Tie wrap for end bracket to fix cables, 125mm	
S-TW150	Tie wrap for end bracket to fix cables, 150mm		

ST 044N

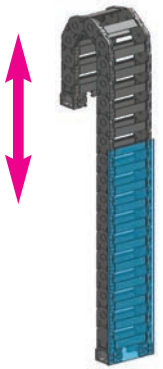
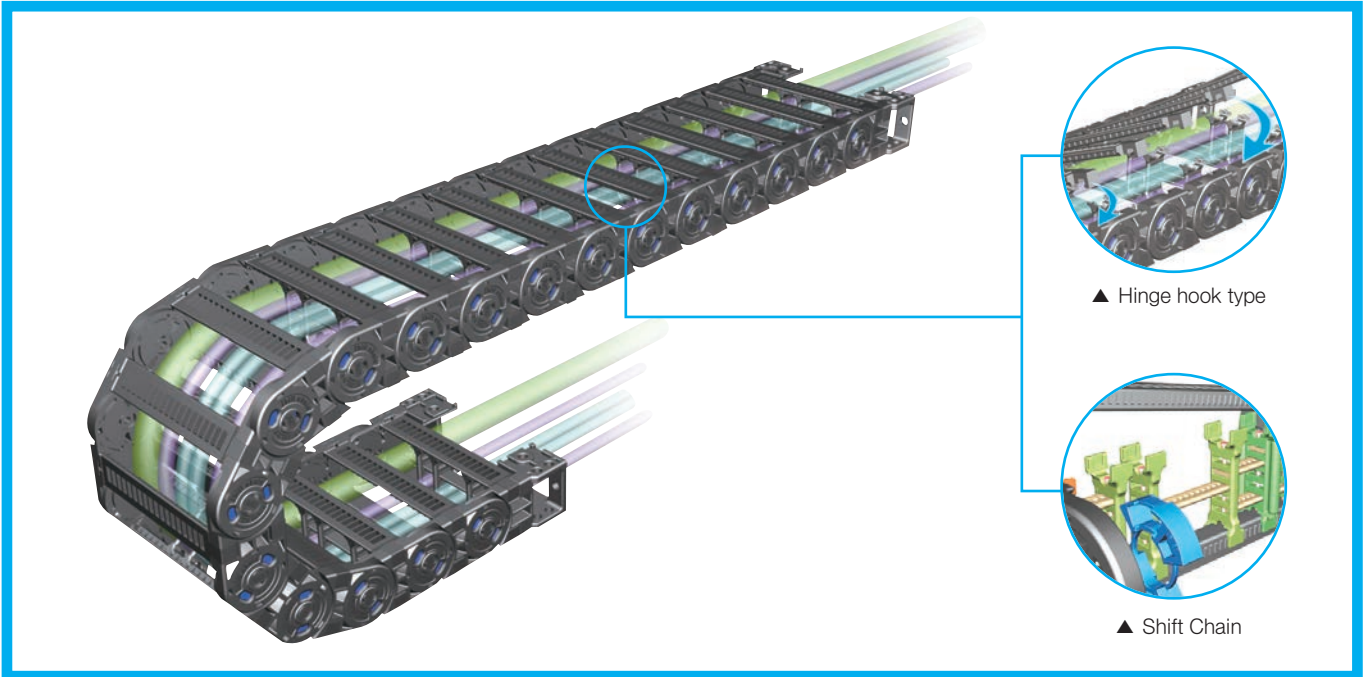

Vertical with curve above

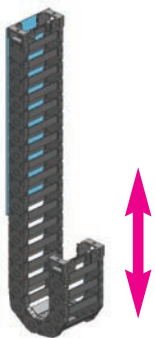

Vertical with curve below

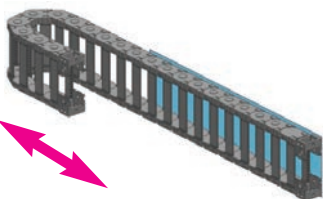

Horizontal application mounted on its side

» Calculation of the chain length

$$\left[L = \frac{L_s}{2} + L_p \right]$$

» Other installation length

Vertical curve above = max 2.0m

Vertical curve below = max 40m

Side Mounted, Unsupported = max 1.0m

» Load diagrams self-supporting length

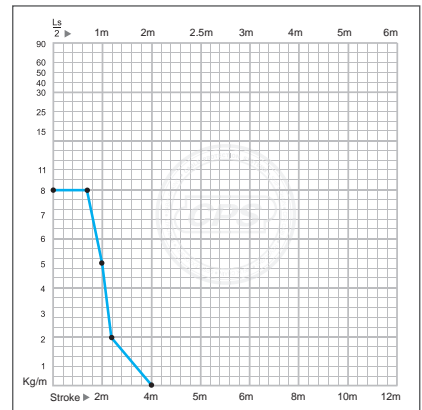

» Layout of the chain

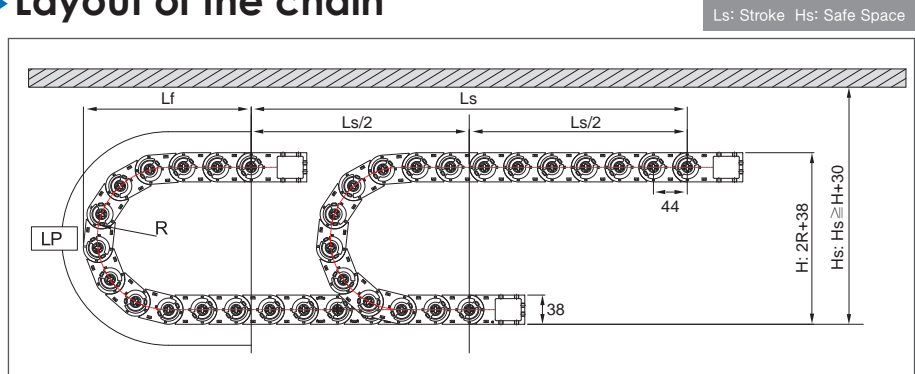

Bending Radius (R)	Lp Loop Length	Lf Loof Projection	H Moving Height
50	333	157	138
70	396	177	178
90	459	197	218
120	553	227	278
150	648	257	338

(Dimensions in mm)

» Chain cross section

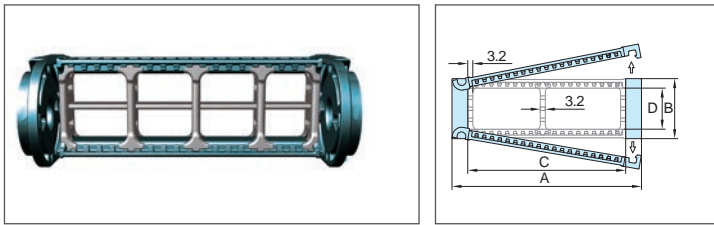

Chain Type	A Width (Outer)	B Height (Outer)	C Frame	D Height (Inner)	Weight kg/m
ST 044N	56	38	35	26	0.93
	71		50		0.97
	76		55		1.00
	96		75		1.06
	121		100		1.17
	146		125		1.30
	171		150		1.43
	196		175		1.78
221	200	1.94			

(Dimensions in mm)

» Free end bracket

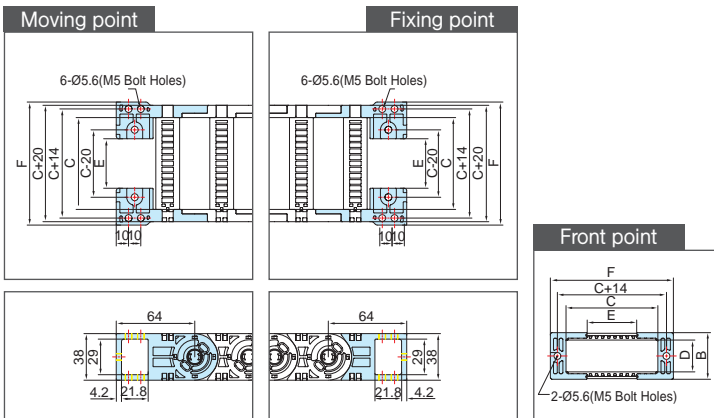

Chain Type	F Width(Outer)	B Height(Outer)	C Frame	D Height(Inner)	E M,EB Bolt hole width	Hole Type
ST 044N	60.4	38	35	26	0.4	M5 Bolt Holes
	75.4		50		15.4	
	80.4		55		20.4	
	100.4		75		40.4	
	125.4		100		65.4	
	150.4		125		90.4	
	175.4		150		115.4	
	200.4		175		140.4	
225.4	200	165.4				

(Dimensions in mm)

» System tie wrap (STW)

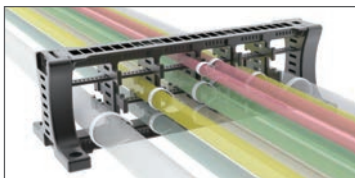

It is a unit to classify each cable for preventing entanglement of cables. It can either be installed to free end bracket or installed separately according its application environment.

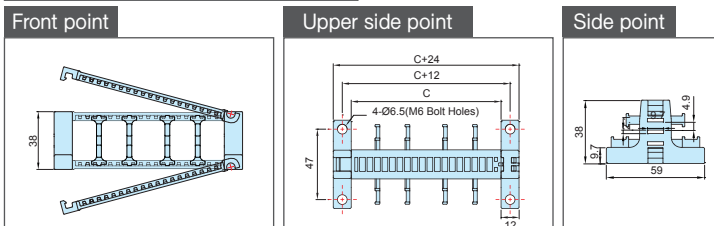

Chain Type	Ordering No.	C Frame	Hole Type
ST 044N	S-TW,EB028,35	35	M6 Bolt Holes
	S-TW,EB028,50	50	
	S-TW,EB028,55	55	
	S-TW,EB028,75	75	
	S-TW,EB028,100	100	
	S-TW,EB028,125	125	
	S-TW,EB028,150	150	
	S-TW,EB028,175	175	
	S-TW,EB028,200	200	

(Dimensions in mm)

» Dividers(DV)

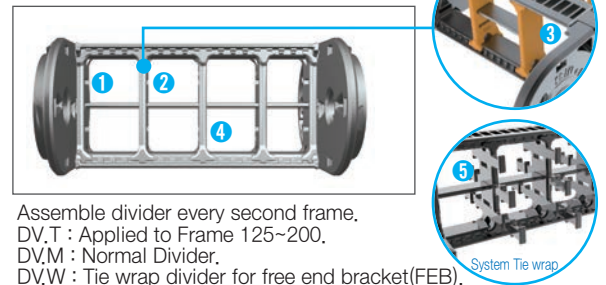

Assemble divider every second frame.
DV.T : Applied to Frame 125~200.
DV.M : Normal Divider.
DV.W : Tie wrap divider for free end bracket(FEB).

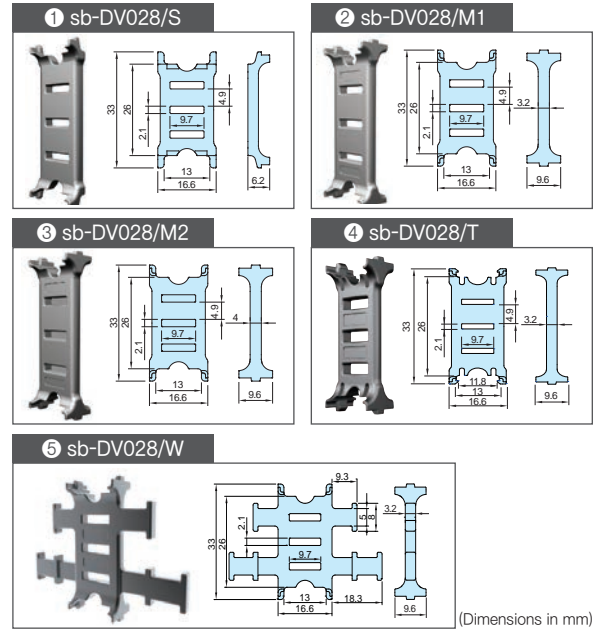

(Dimensions in mm)

» Separators(SP)

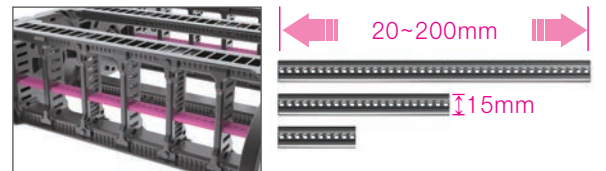

Chain Type	Ordering NO.	Frame
ST 044N	S-SP/M,35	35
	S-SP/M,50	50
	S-SP/M,55	55
	S-SP/M,75	75
	S-SP/M,100	100
	S-SP/M,125	125
	S-SP/M,150	150
	S-SP/M,175	175
	S-SP/M,200	200

» Tie wrap (TW)

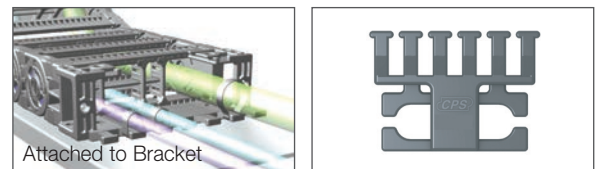

Chain Type	Ordering No.	A	B	C
ST 044N	S-TW036/025CR,35	46	35.4	-
	S-TW036/025CR,50	69	48.9	15
	S-TW036/025CR,55	70	48.9	20
	S-TW036/025CR,75	94	48.9	40
	S-TW036/025CR,100	118	48.9	65
	S-TW036/025CR,125	142	48.9	90

(Dimensions in mm)

ST 055N

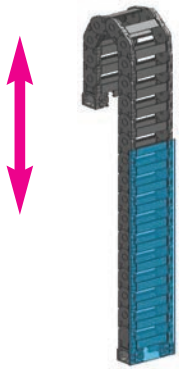
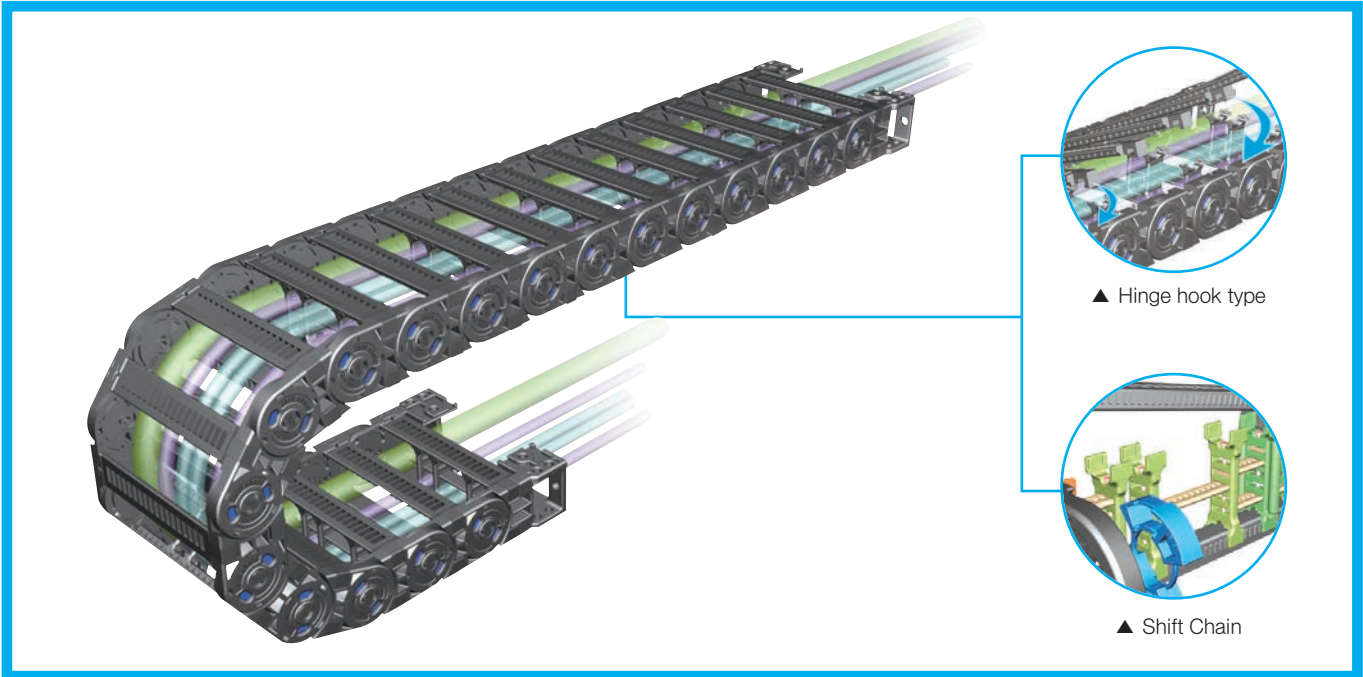

Vertical with curve above

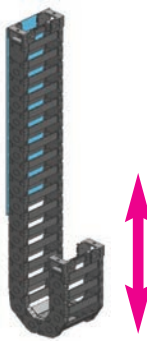

Vertical with curve below

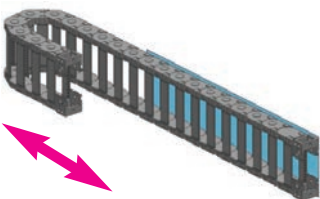

Horizontal application mounted on its side

» Calculation of the chain length

$$\left[L = \frac{L_s}{2} + L_p \right]$$

» Other installation length

Vertical curve above = max 3.0m

Vertical curve below = max 50m

Side Mounted, Unsupported = max 1.0m

» Load diagrams self-supporting length

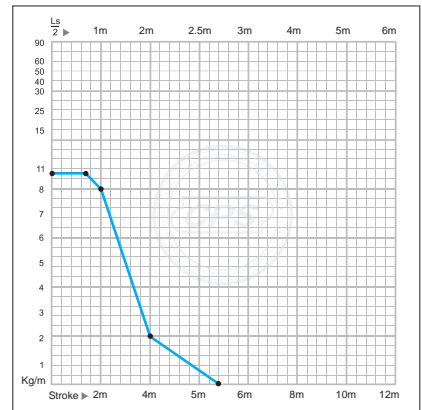

» Layout of the chain

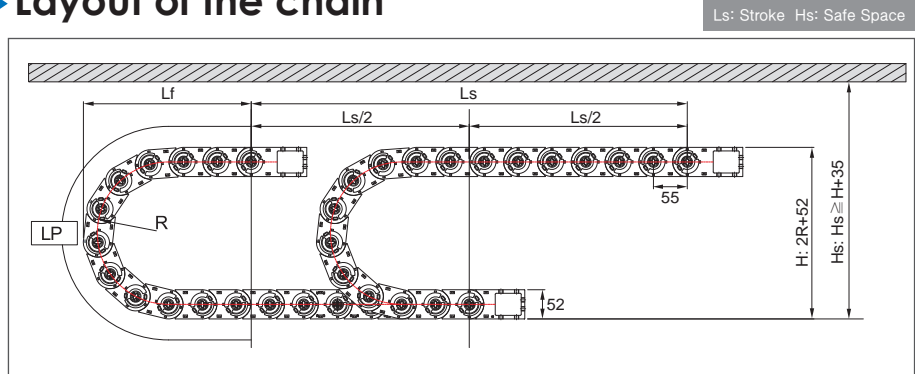

Bending Radius (R)	Lp Loop Length	Lf Loof Projection	H Moving Height
65	424	201	182
75	456	211	202
100	535	236	252
125	613	261	302
150	692	286	352
200	849	336	452

(Dimensions in mm)

» Chain cross section

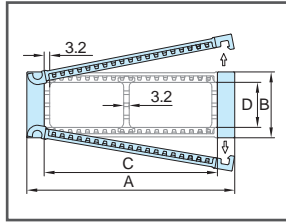
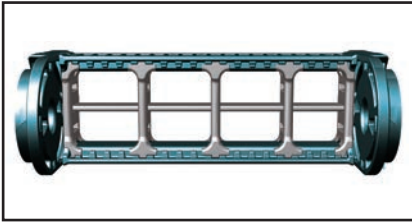

Chain Type	A Width (Outer)	B Height (Outer)	C Frame	D Height (Inner)	Weight kg/m
ST 055N	56	52	35	40	1.12
	71		50		1.15
	76		55		1.18
	96		75		1.23
	121		100		1.31
	146		125		1.41
	171		150		1.51
	196		175		1.78
221	200	1.92			

(Dimensions in mm)

» Free end bracket

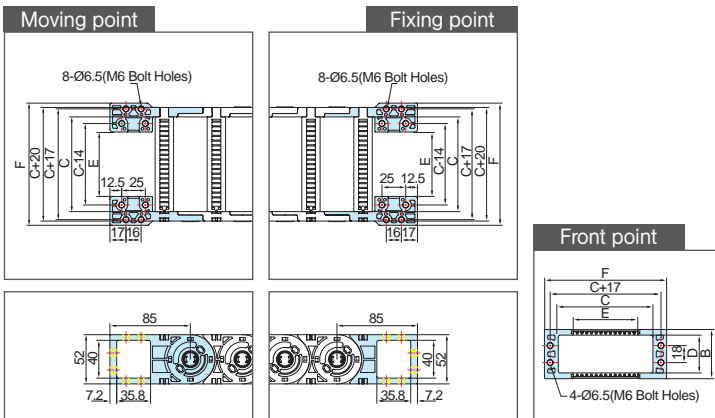

Chain Type	F Width(Outer)	B Height(Outer)	C Frame	D Height(Inner)	E M,EB Bolt hole width	Hole Type
ST 055N	64	52	35	40	3	M6 Holes
	79		50		18	
	84		55		23	
	104		75		43	
	129		100		68	
	154		125		93	
	179		150		118	
	204		175		143	
229	200	168				

(Dimensions in mm)

» System tie wrap (STW)

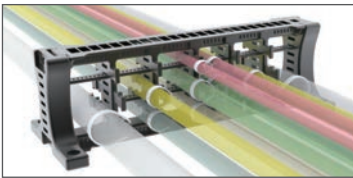

It is a unit to classify each cable for preventing entanglement of cables. It can either be installed to free end bracket or installed separately according its application environment.

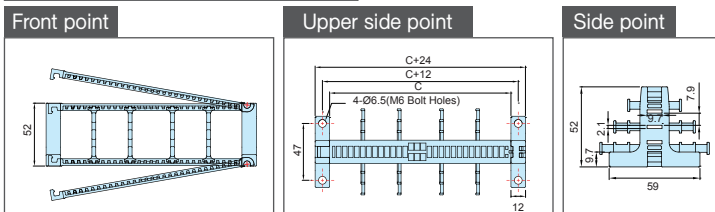

Chain Type	Ordering No.	C Frame	Hole Type
ST 055N	S-TWEB035,35	35	M6 Bolt Holes
	S-TWEB035,50	50	
	S-TWEB035,55	55	
	S-TWEB035,75	75	
	S-TWEB035,100	100	
	S-TWEB035,125	125	
	S-TWEB035,150	150	
	S-TWEB035,175	175	
	S-TWEB035,200	200	

(Dimensions in mm)

» Dividers(DV)

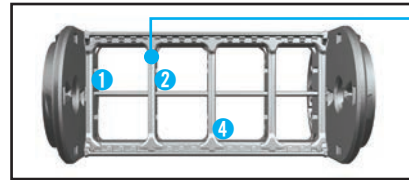

Assemble divider every second frame.
 DV.T : Applied to Frame 125~200.
 DV.M : Normal Divider.
 DV.W : Tie wrap divider for free end bracket(FEB), System Tiewrap

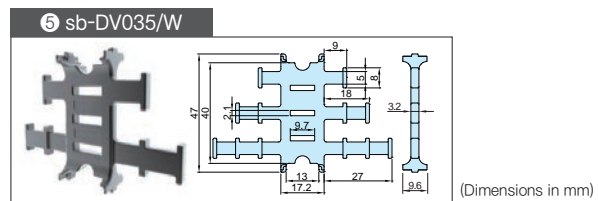
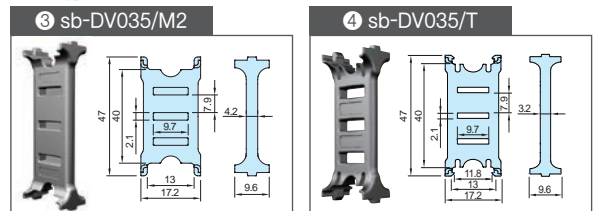
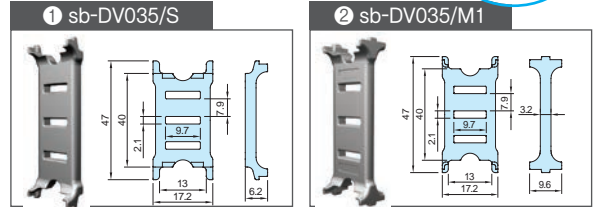
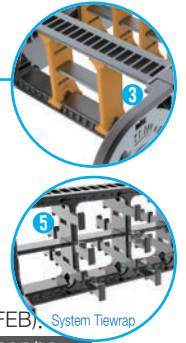

(Dimensions in mm)

» Separators(SP)

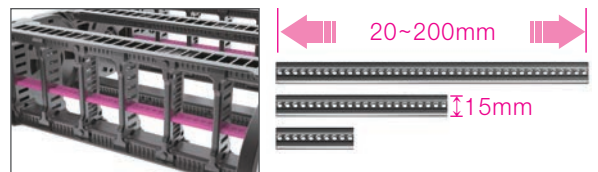

Chain Type	Ordering NO.	Frame
ST 055N	S-SP/M,35	35
	S-SP/M,50	50
	S-SP/M,55	55
	S-SP/M,75	75
	S-SP/M,100	100
	S-SP/M,125	125
	S-SP/M,150	150
	S-SP/M,175	175
	S-SP/M,200	200

» Tie wrap (TW)

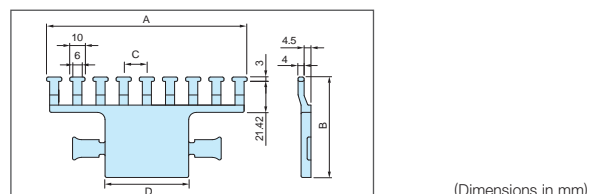

(Dimensions in mm)

Chain Type	Ordering No.	A	B	C	D
ST 055N	S-TW050/035N,50	82	64.5	12.00	5
	S-TW050/035N,55	82		12.00	10
	S-TW050/035N,75	107		12.13	30
	S-TW050/035N,100	132		15.25	55
	S-TW050/035N,125	157		14.70	80
	S-TW050/035N,150	182		14.35	105
	S-TW050/035N,175	203		12.31	130
	S-TW050/035N,200	232		13.88	155

ST 072N

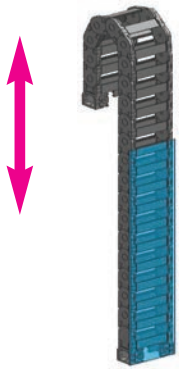
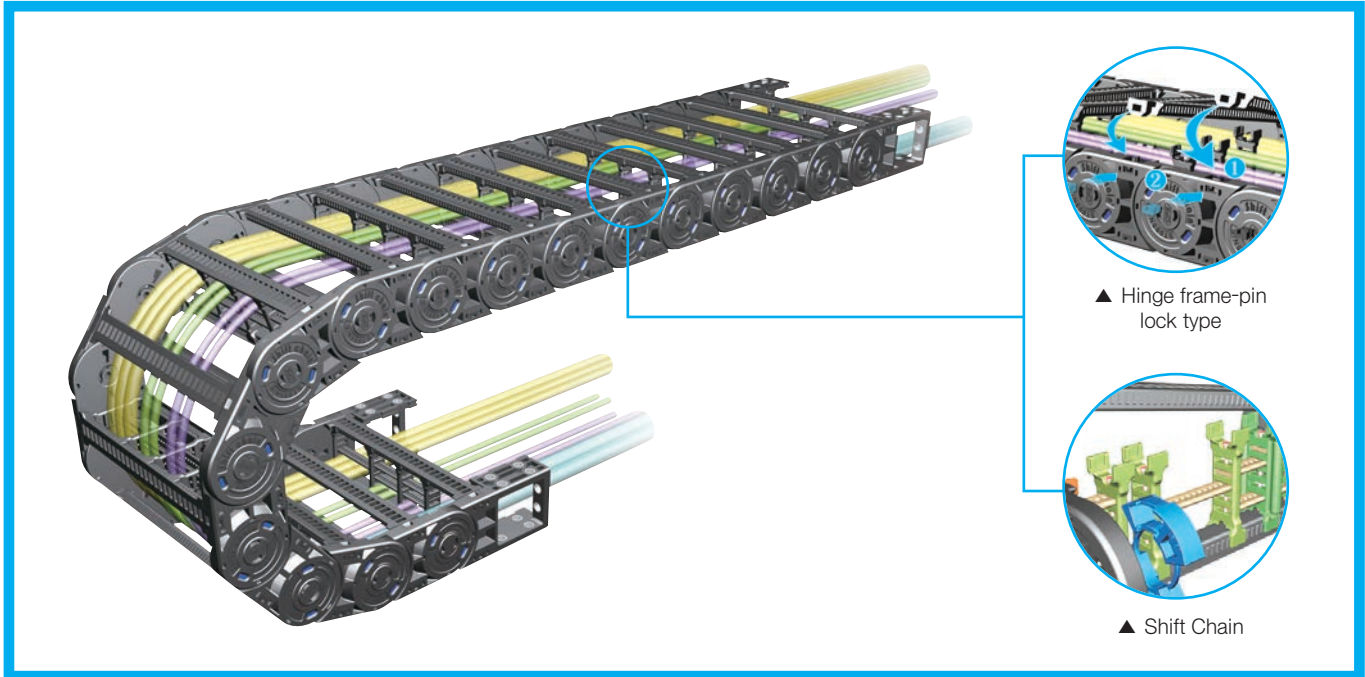

Vertical with curve above

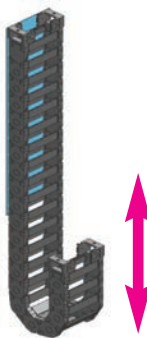

Vertical with curve below

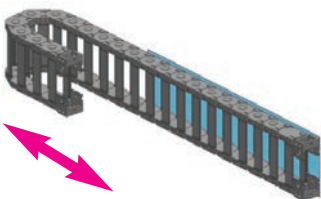

Horizontal application mounted on its side

» Calculation of the chain length

$$\left[L = \frac{L_s}{2} + L_p \right]$$

» Other installation length

Vertical curve above = max 6.0m

Vertical curve below = max 100m

Side Mounted, Unsupported = max 2.5m

» Load diagrams self-supporting length

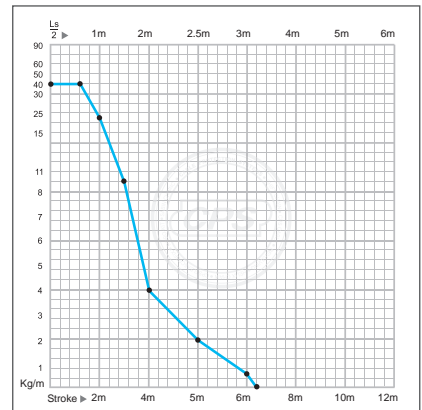

» Layout of the chain

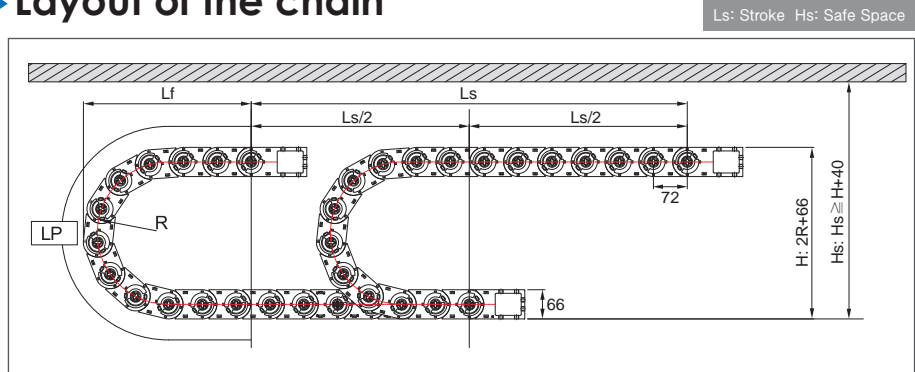

Bending Radius (R)	L _p Loop Length	L _f Loof Projection	H Moving Height
72	514	249	210
100	603	277	266
120	665	297	306
145	743	322	356
200	916	377	466
250	1,074	427	566
300	1,230	477	666

(Dimensions in mm)

» Chain cross section

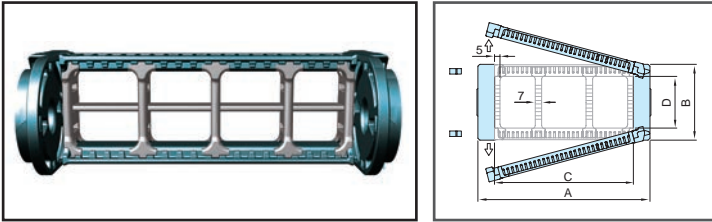

Chain Type	A Width (Outer)	B Height (Outer)	C Frame	D Height (Inner)	Weight kg/m
ST 072N	82	66	50	45	2.10
	107		75		2.20
	132		100		2.30
	157		125		2.43
	172		140		2.51
	182		150		2.56
	197		165		2.62
	207		175		2.66
	222		190		2.93
	232		200		3.11
	272		240		3.21
	282		250		3.24
	332		300		3.60

(Dimensions in mm)

» Free end bracket

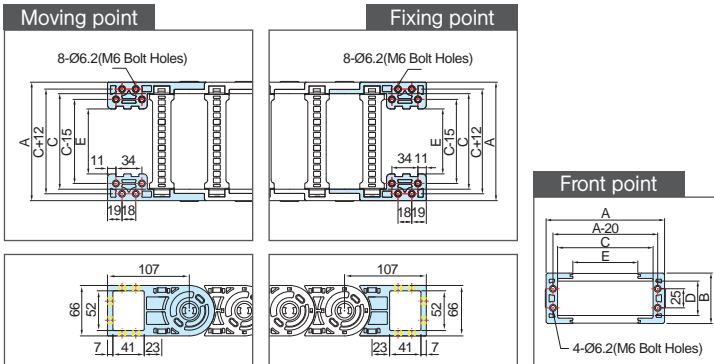

Chain Type	A Width(Outer)	B Height(Outer)	C Frame	D Height(Inner)	E M,EB Bolt hole width	Hole Type
ST 072N	82	66	50	45	10	M6 Bolt Holes
	107		35			
	132		60			
	157		85			
	172		100			
	182		110			
	197		125			
	207		135			
	222		150			
	232		160			
	272		200			
	282		210			
	332		260			

(Dimensions in mm)

» System tie wrap (STW)



It is a unit to classify each cable for preventing entanglement of cables. It can either be installed to free end bracket or installed separately according its application environment.

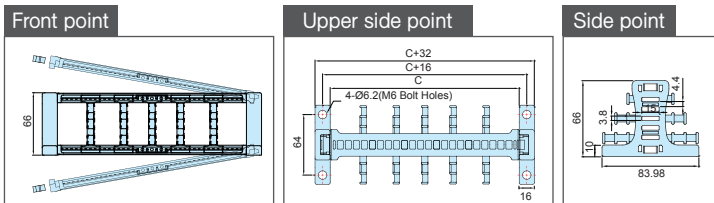

Chain Type	Ordering No.	C Frame	Hole Type
ST 072N	S-TWEB045.50	50	M6 Bolt Holes
	S-TWEB045.75	75	
	S-TWEB045.100	100	
	S-TWEB045.125	125	
	S-TWEB045.140	140	
	S-TWEB045.150	150	
	S-TWEB045.165	165	
	S-TWEB045.175	175	
	S-TWEB045.190	190	
	S-TWEB045.200	200	
	S-TWEB045.240	240	
	S-TWEB045.250	250	
	S-TWEB045.300	300	

(Dimensions in mm)

» Dividers(DV)

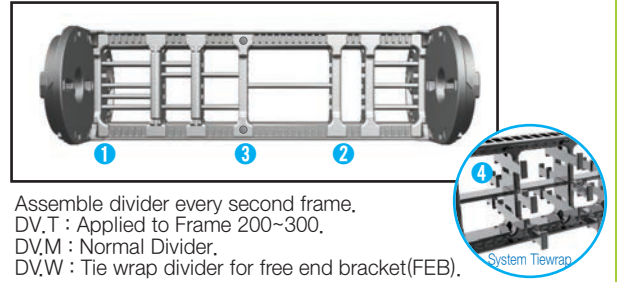

Assemble divider every second frame.
DV.T : Applied to Frame 200~300.
DV.M : Normal Divider.
DV.W : Tie wrap divider for free end bracket(FEB).

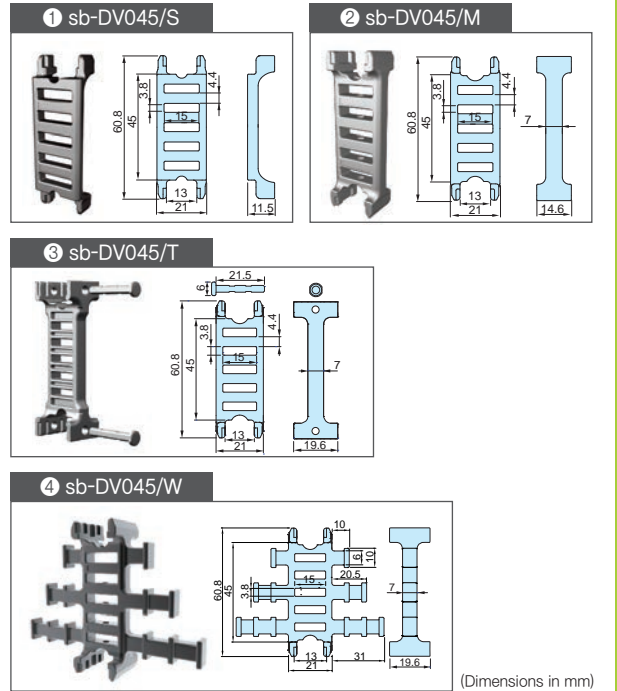

(Dimensions in mm)

» Separators(SP)

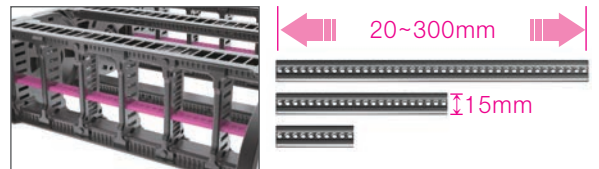

Chain Type	Ordering NO.
ST 072N	sb-SP/400,400

» Tie wrap (TW)

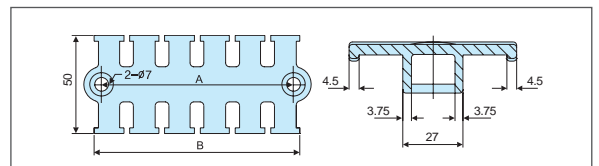
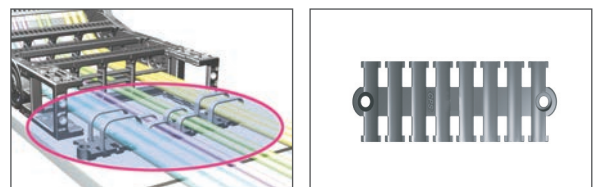

Chain Type	Ordering No.	A	B
ST 072N	S-TW50	58	65
	S-TW75	75	82
	S-TW100	98	105
	S-TW125	122	129
	S-TW150	141	148

(Dimensions in mm)

ST 095N

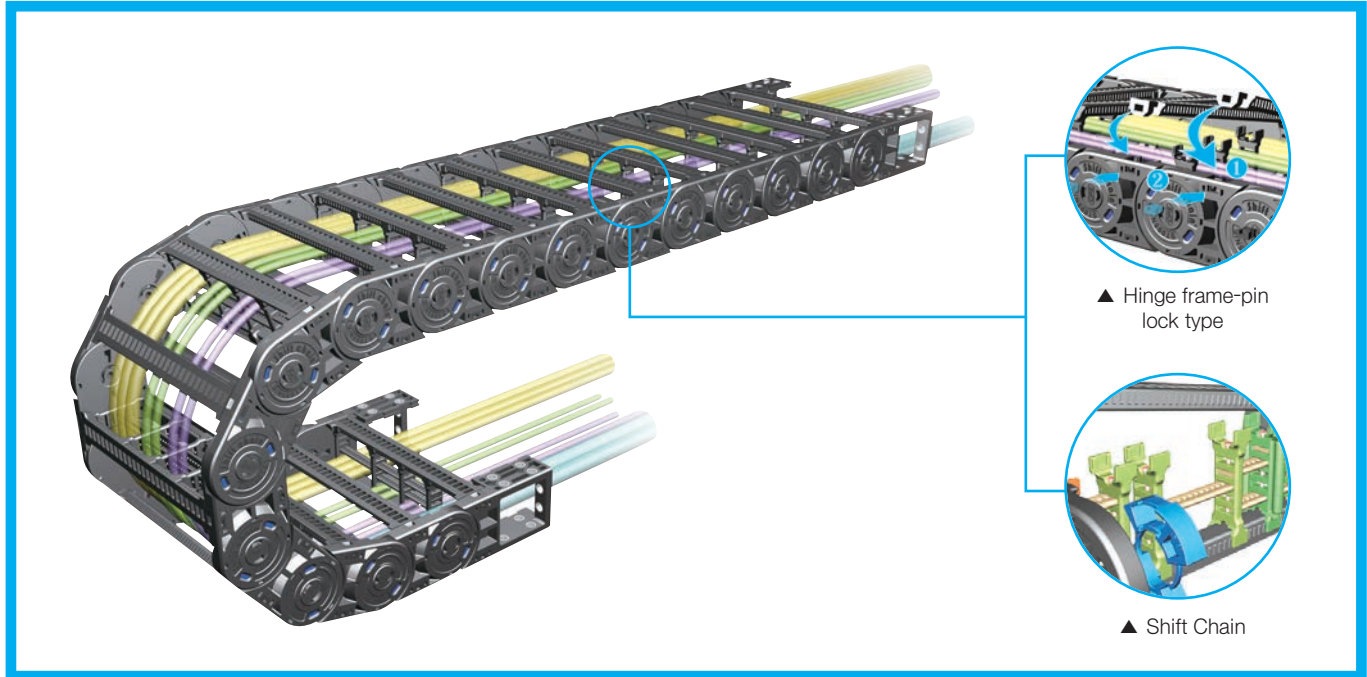

▲ Hinge frame-pin lock type

▲ Shift Chain

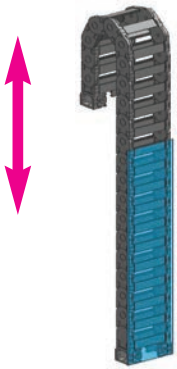

Vertical with curve above

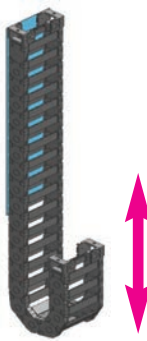

Vertical with curve below

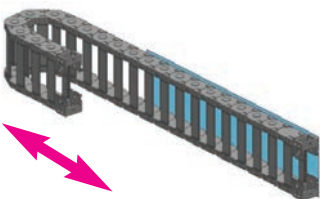

Horizontal application mounted on its side

» Calculation of the chain length

$$\left[L = \frac{L_s}{2} + L_p \right]$$

» Other installation length

Vertical curve above = max 6.0m

Vertical curve below = max 100m

Side Mounted, Unsupported = max 3.0m

» Load diagrams self-supporting length

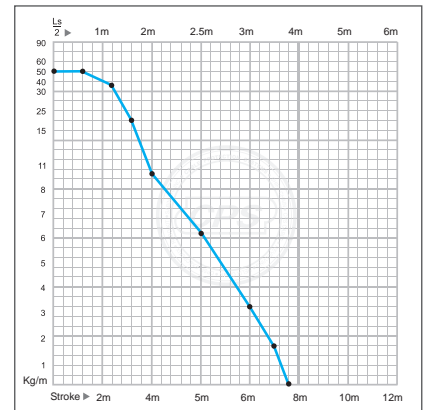

» Layout of the chain

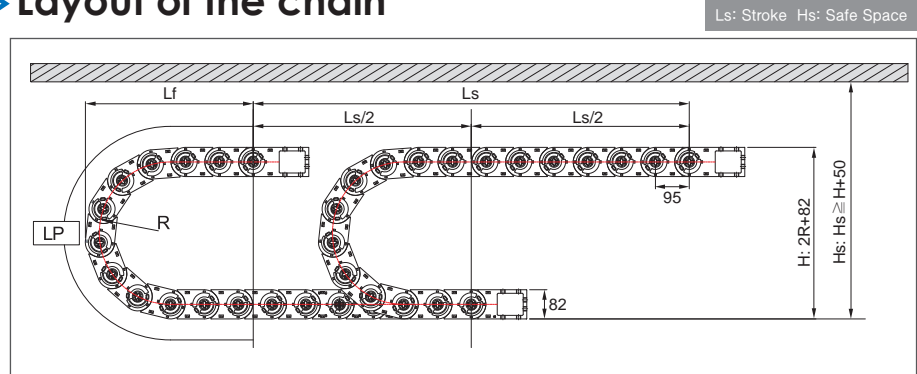

Bending Radius (R)	Lp Loop Length	Lf Loof Projection	H Moving Height
135	805	364	352
150	855	374	382
200	1,010	428	482
230	1,110	459	542
280	1,260	505	642
400	1,640	629	882

(Dimensions in mm)

» Chain cross section

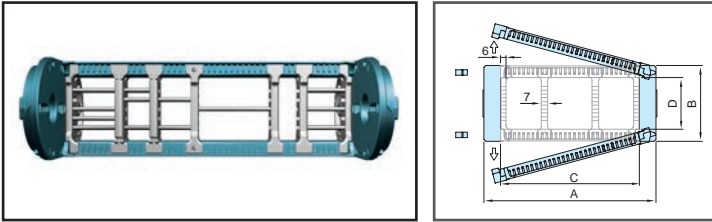

Chain Type	A Width (Outer)	B Height (Outer)	C Frame	D Height (Inner)	Weight kg/m
ST 095N	113	82	75	56	3.11
	138		100		3.17
	163		125		3.37
	188		150		3.49
	213		175		3.60
	228		190		3.71
	238		200		3.79
	268		230		3.95
	278		240		4.00
	288		250		4.05
	338		300		4.31
	388		350		4.69
	438		400		5.05

(Dimensions in mm)

» Free end bracket

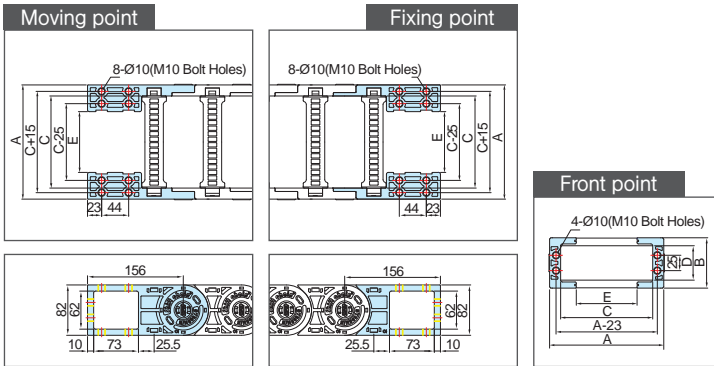

Chain Type	A Width(Outer)	B Height(Outer)	C Frame	D Height(Inner)	E M,EB Bolt hole width	Hole Type
ST 095N	113	82	75	56	24	M10 Bolt Holes
	138		100		49	
	163		125		74	
	188		150		99	
	213		175		124	
	228		190		139	
	238		200		149	
	268		230		179	
	278		240		189	
	288		250		199	
	338		300		249	
	388		350		299	
	438		400		349	

(Dimensions in mm)

» System tie wrap (STW)

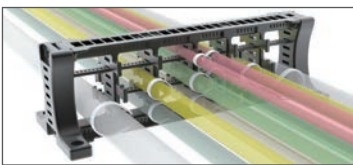

It is a unit to classify each cable for preventing entanglement of cables. It can either be installed to free end bracket or installed separately according its application environment.

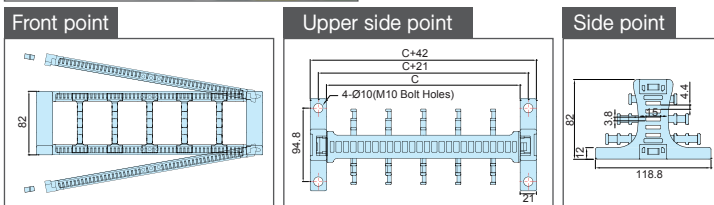

Chain Type	Ordering No.	C Frame	Hole Type
ST 095N	S-TW,EB060.75	75	M10 Bolt Holes
	S-TW,EB060.100	100	
	S-TW,EB060.125	125	
	S-TW,EB060.150	150	
	S-TW,EB060.175	175	
	S-TW,EB060.190	190	
	S-TW,EB060.200	200	
	S-TW,EB060.230	230	
	S-TW,EB060.240	240	
	S-TW,EB060.250	250	
	S-TW,EB060.300	300	
	S-TW,EB060.350	350	
	S-TW,EB060.400	400	

(Dimensions in mm)

» Dividers(DV)

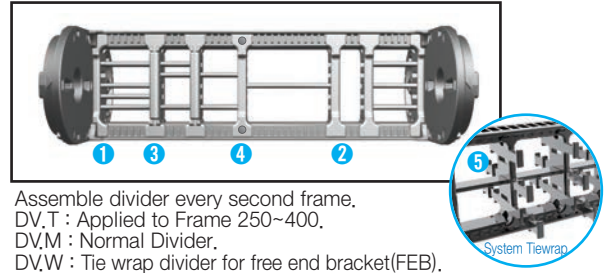

Assemble divider every second frame.
 DV.T : Applied to Frame 250~400.
 DV.M : Normal Divider.
 DV.W : Tie wrap divider for free end bracket(FEB).

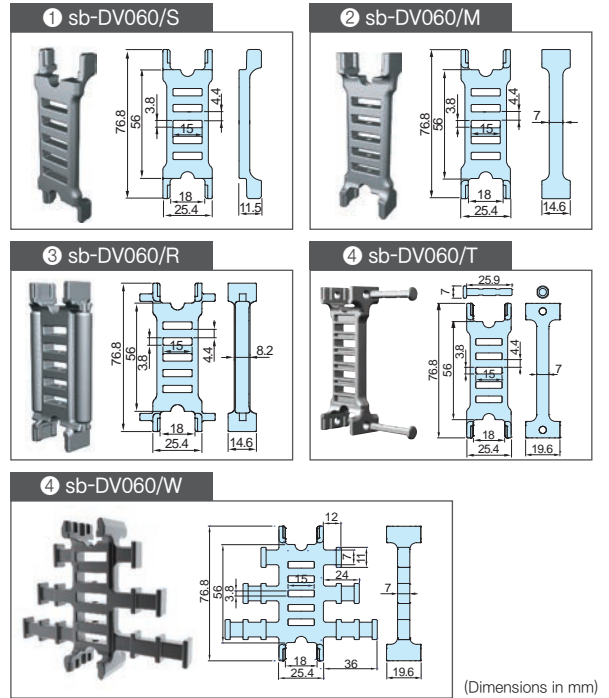
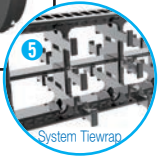

(Dimensions in mm)

» Separators(SP)

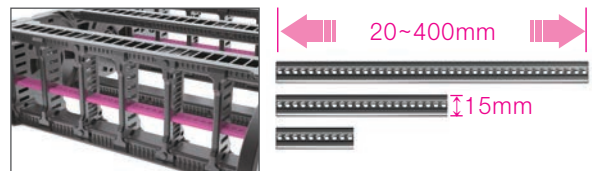

Chain Type	Ordering NO.
ST 095N	sb-SP/400,400

» Tie wrap (TW)

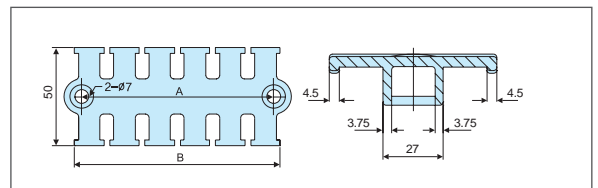
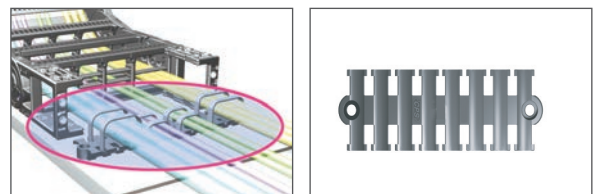

Chain Type	Ordering No.	A	B
ST 095N	S-TW50	58	65
	S-TW75	75	82
	S-TW100	98	105
	S-TW125	122	129
	S-TW150	141	148

(Dimensions in mm)

ST 120N

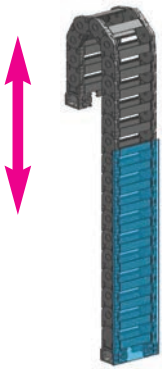
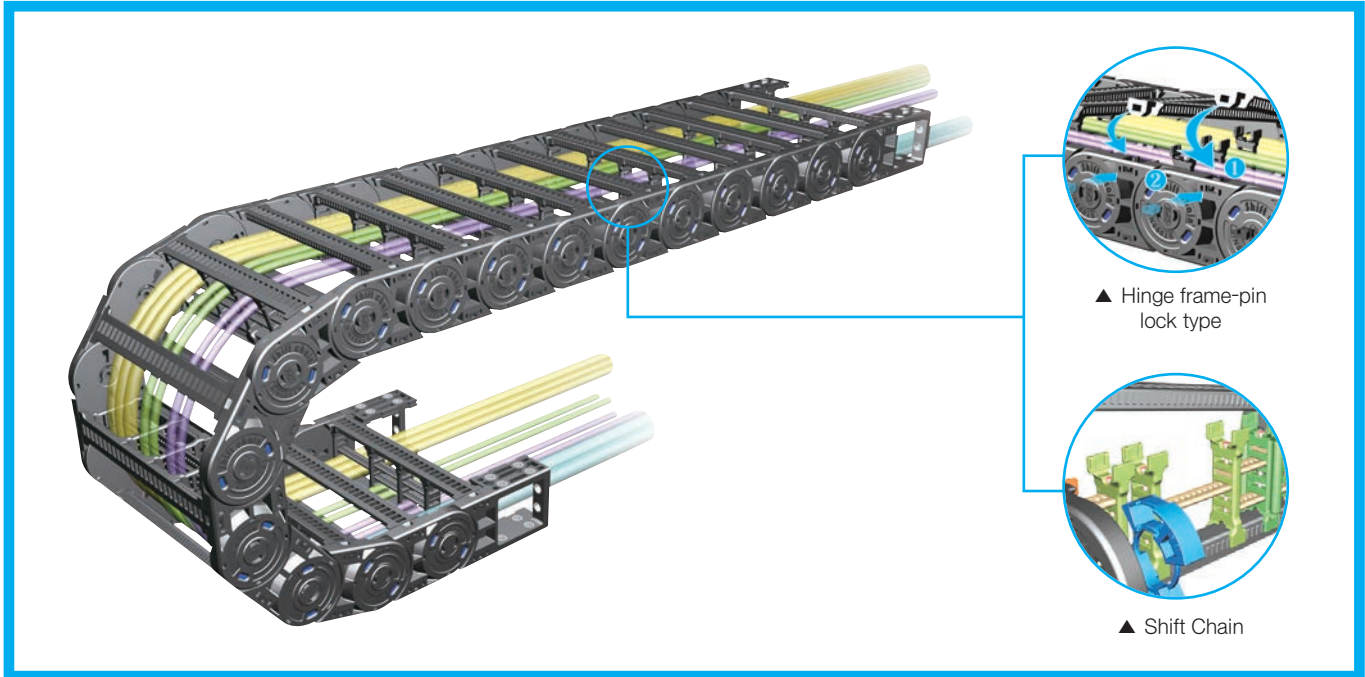

Vertical with curve above

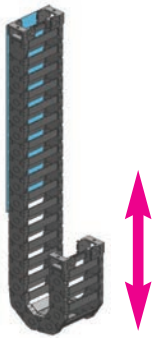

Vertical with curve below

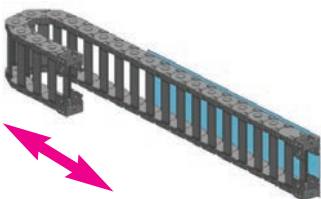

Horizontal application mounted on its side

» Calculation of the chain length

$$\left[L = \frac{L_s}{2} + L_p \right]$$

» Other installation length

Vertical curve above = max 6.0m

Vertical curve below = max 120m

Side Mounted, Unsupported = max 3.0m

» Load diagrams self-supporting length

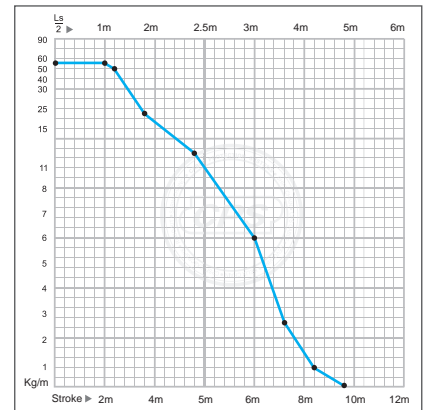

» Layout of the chain

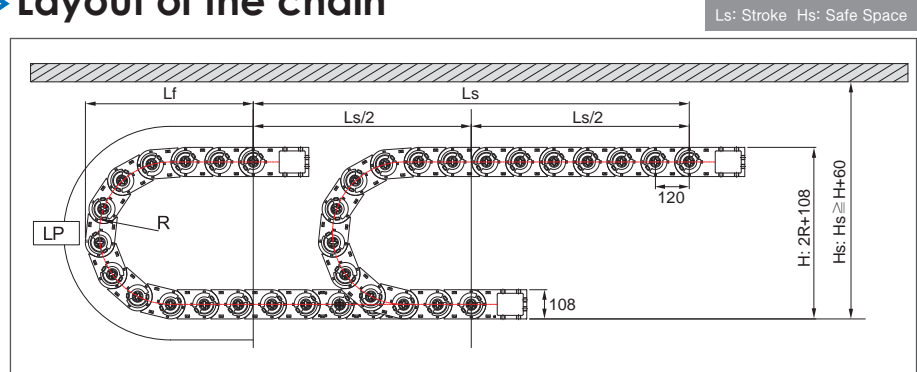

Bending Radius (R)	Lp Loop Length	Lf Loof Projection	H Moving Height
180	1,046	474	468
200	1,109	494	508
250	1,266	544	608
300	1,423	594	708
350	1,580	644	808
400	1,737	694	908
500	2,051	794	1,108

(Dimensions in mm)

» Chain cross section

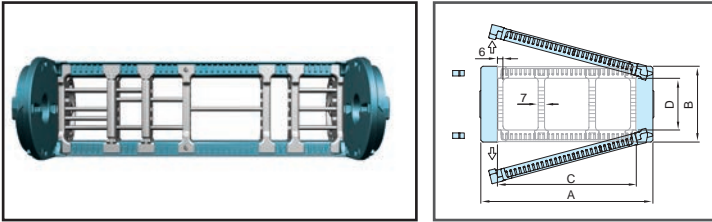

Chain Type	A Width (Outer)	B Height (Outer)	C Frame	D Height (Inner)	Weight kg/m
ST 120N	117	108	75	78	4.41
	142		100		4.53
	157		115		4.61
	167		125		4.67
	192		150		4.78
	217		175		4.93
	242		200		5.17
	282		240		5.41
	292		250		5.47
	332		290		5.80
	342		300		5.88
	392		350		6.30
	442		400		6.73
	492		450		7.07
	542		500		7.30
	592		550		8.13
642	600	8.30			

(Dimensions in mm)

» Free end bracket

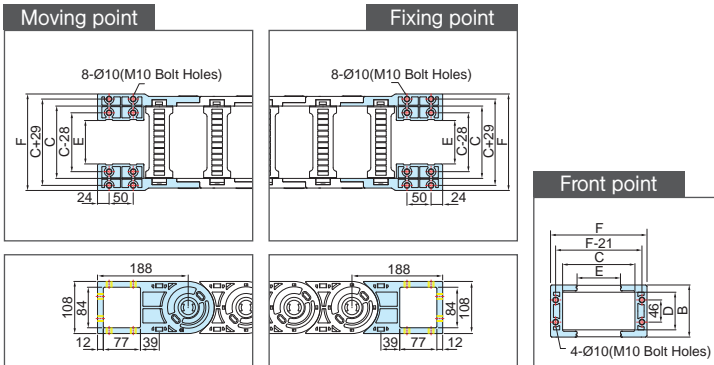

Chain Type	A Width(Outer)	B Height(Outer)	C Frame	D Height(Inner)	E M,EB Bolt hole width	Hole Type
ST 120N	125	108	75	78	15	M10 Bolt Holes
	150		100		40	
	165		115		55	
	175		125		65	
	200		150		90	
	225		175		115	
	250		200		140	
	290		240		180	
	300		250		190	
	340		290		230	
	350		300		240	
	400		350		290	
	450		400		340	
	500		450		390	
	550		500		440	
	600		550		490	
650	600	540				

(Dimensions in mm)

» System tie wrap (STW)

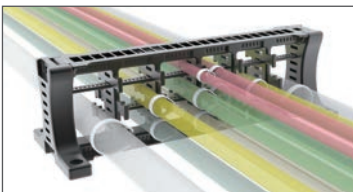

It is a unit to classify each cable for preventing entanglement of cables. It can either be installed to free end bracket or installed separately according its application environment.

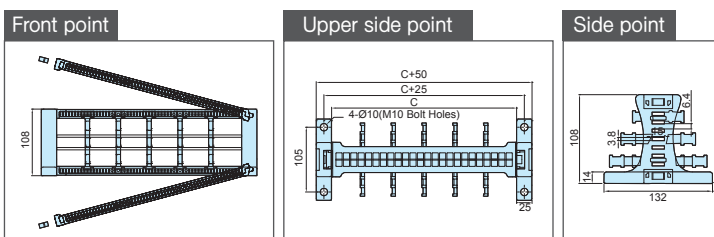

» Dividers(DV)

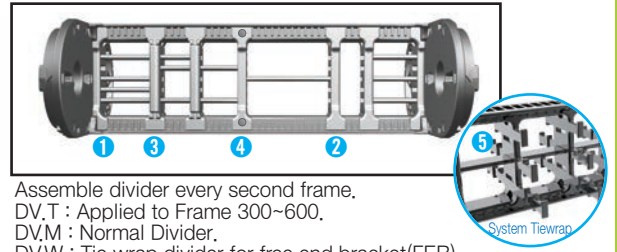

Assemble divider every second frame.
 DV.T : Applied to Frame 300~600.
 DV.M : Normal Divider.
 DV.W : Tie wrap divider for free end bracket(FEB).

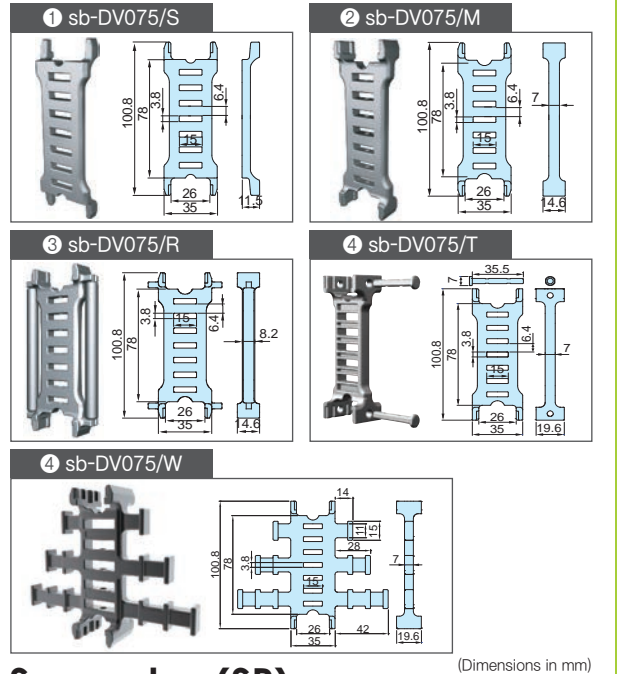

(Dimensions in mm)

» Separators(SP)

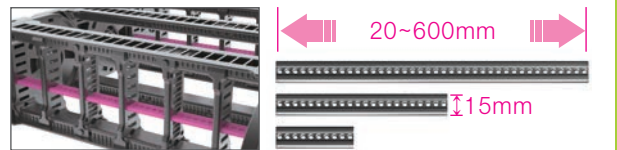

Chain Type	Ordering NO.
ST 120N	sb-SP/600,600

» Tie wrap (TW)

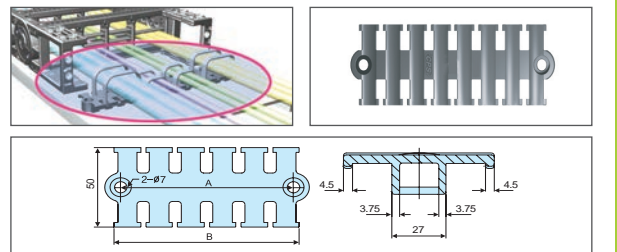

Chain Type	Ordering No.	A	B
ST 120N	S-TW50	58	65
	S-TW75	75	82
	S-TW100	98	105
	S-TW125	122	129
	S-TW150	141	148

Chain Type	Ordering No.	C Frame	Hole Type
ST 120N	S-TWEB075.75	75	M10 Bolt Holes
	S-TWEB075.100	100	
	S-TWEB075.115	115	
	S-TWEB075.125	125	
	S-TWEB075.150	150	
	S-TWEB075.175	175	
	S-TWEB075.200	200	
	S-TWEB075.240	240	
	S-TWEB075.250	250	
	S-TWEB075.290	290	
	S-TWEB075.300	300	
	S-TWEB075.350	350	
	S-TWEB075.400	400	
	S-TWEB075.450	450	
	S-TWEB075.500	500	
	S-TWEB075.550	550	
S-TWEB075.600	600		

ST 150N

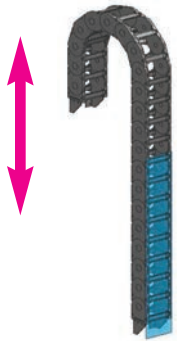
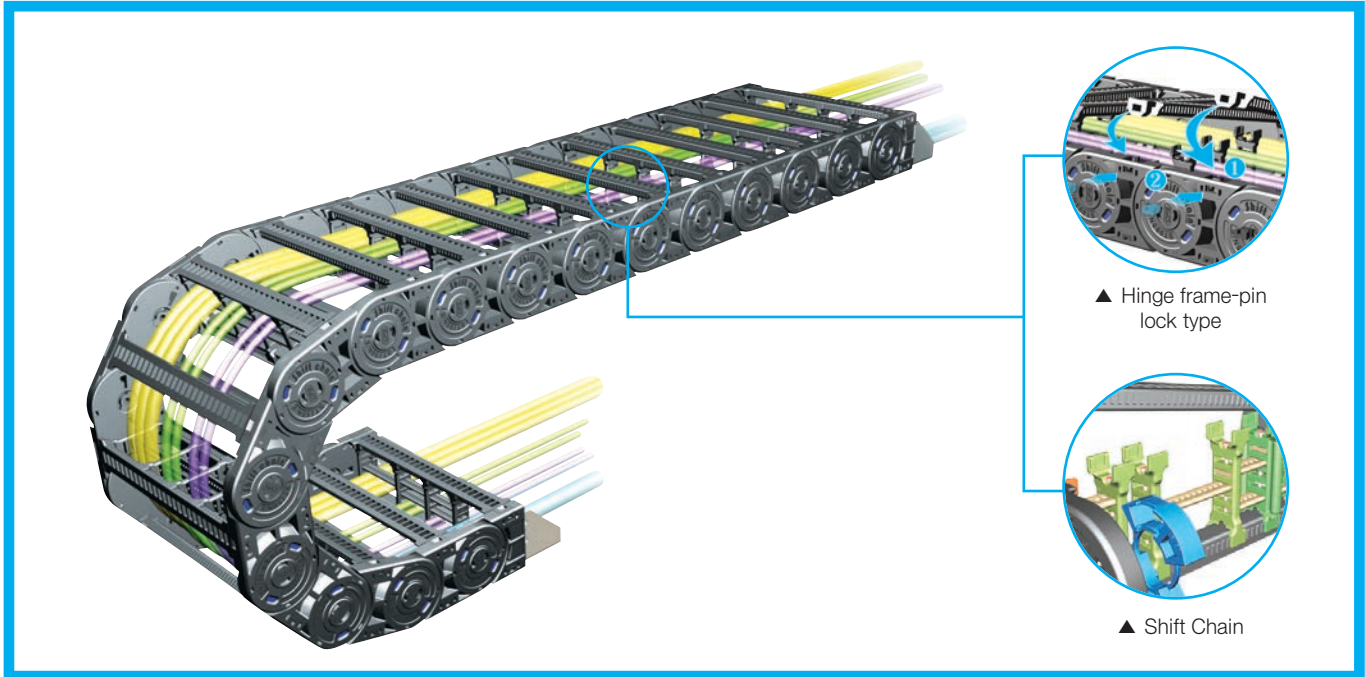

Vertical with curve above

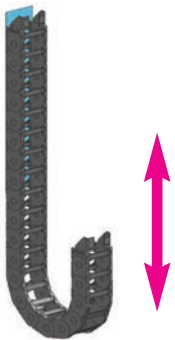

Vertical with curve below

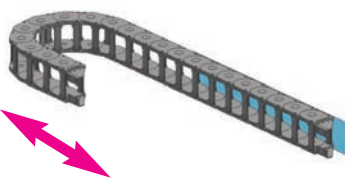

Horizontal application mounted on its side

» Calculation of the chain length

$$\left[L = \frac{L_s}{2} + L_p \right]$$

» Other installation length

Vertical curve above = max 7.0m

Vertical curve below = max 150m

Side Mounted, Unsupported = max 4.0m

» Load diagrams self-supporting length

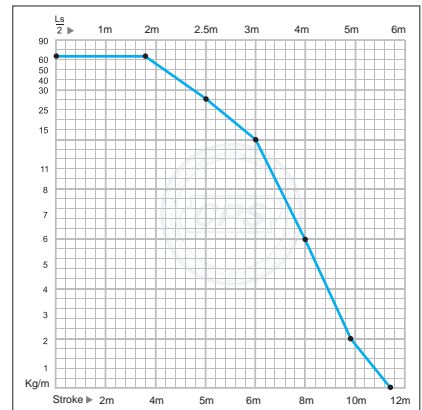

» Layout of the chain

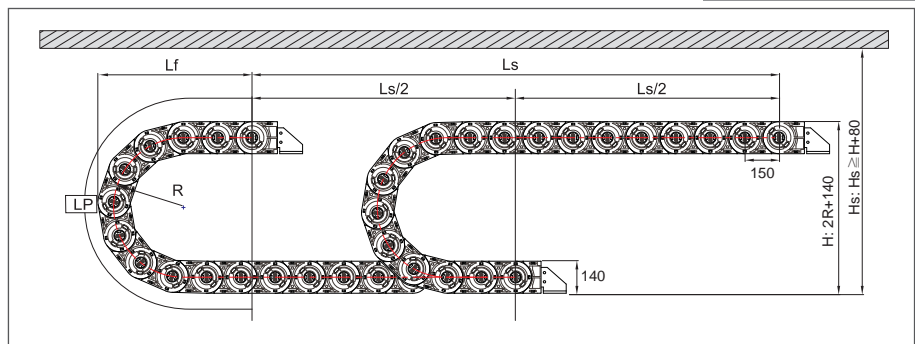

Ls: Stroke Hs: Safe Space

Bending Radius (R)	Lp Loop Length	Lf Loof Projection	H Moving Height
205	1,215	561	550
305	1,510	651	750
405	1,807	743	950
505	2,106	835	1,150
605	2,405	928	1,350

(Dimensions in mm)

» Chain cross section

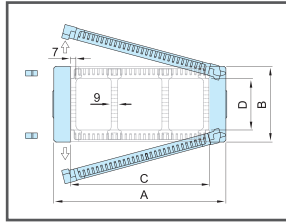
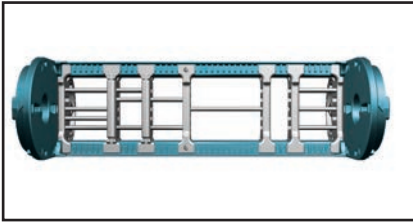

Chain Type	A Width (Outer)	B Height (Outer)	C Frame	D Height (Inner)	Weight kg/m
ST 150N	121	140	75	110	5.85
	146		100		5.96
	161		115		6.03
	171		125		6.08
	196		150		6.18
	221		175		6.30
	246		200		6.51
	286		240		6.72
	296		250		6.78
	336		290		7.06
	346		300		7.14
	396		350		7.51
	446		400		7.88
	496		450		8.18
	546		500		8.37
	596		550		9.11
646	600	9.26			

(Dimensions in mm)

» Free end bracket

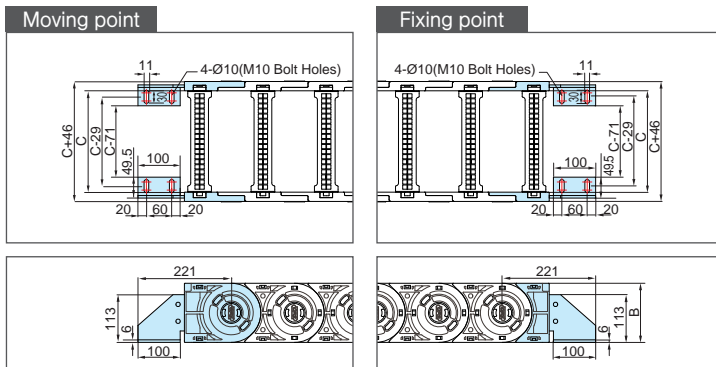

Chain Type	B Height(Outer)	C Frame	D Height(Inner)	Hole Type
ST 150N	140	75	110	M10 Bolt Holes
		100		
		115		
		125		
		150		
		175		
		200		
		240		
		250		
		290		
		300		
		350		
		400		
		450		
		500		
		550		
600				

(Dimensions in mm)

» Dividers(DV)

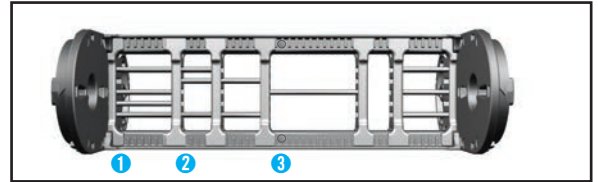

Assemble divider every second frame.

DV.M : Normal Divider.

DV.T : Applied to Frame 300~600.

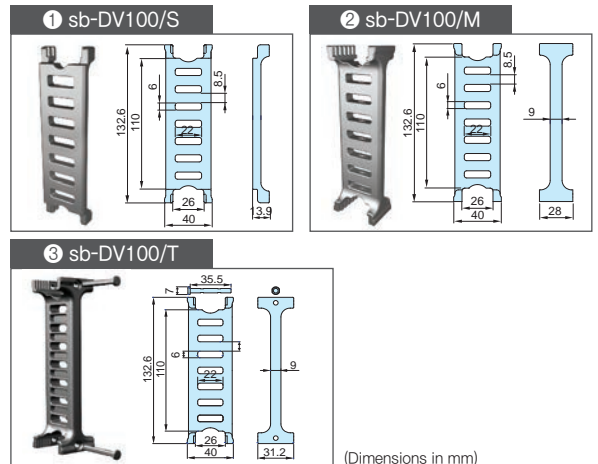

(Dimensions in mm)

» Separators(SP)

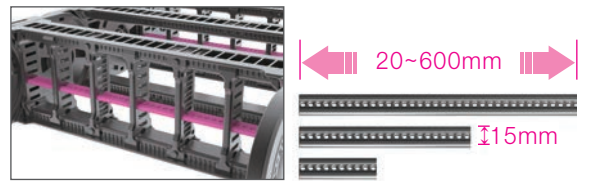

Chain Type	Ordering NO.
ST 150N	sb-SP/600,600

» Tie wrap (TW)

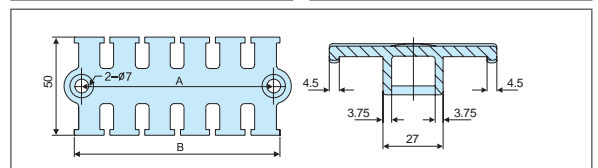
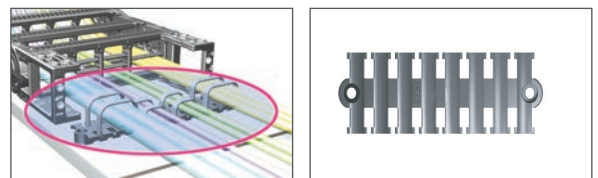

Chain Type	Ordering No.	A	B
ST 150N	S-TW50	58	65
	S-TW75	75	82
	S-TW100	98	105
	S-TW125	122	129
	S-TW150	141	148

(Dimensions in mm)