



NCS-TT106H-V2.0 Intelligent HART Temperature Transmitter

User Manual

Warning

1. It is forbidden for users to disassemble the temperature module by themselves.
2. Please check if the supply voltage of temperature transmitter meets the power supply voltage requirements in the manual.

Company Introduction

Microcyber Corporation, established as a high-tech enterprise by the Shenyang Institute of Automation Chinese Academy of Sciences, mainly engages in advanced industrial control systems, equipments, instruments and chips for industrial process automation control solutions in the research, development, production and application. Microcyber undertakes a number of national scientific and technical key task and “863” project, and has Liaoning

Province networked control systems engineering research center. The company successfully developed the FF H1 fieldbus protocol stack which is number one to be approved

internationally in China, and the Industrial Ethernet Protocol(HSE) which is number one to be approved in China, and the domestic first fieldbus instrument which has a function of national-level intrinsically safe explosion--proof and safety barrier. Also Microcyber participated in the drafting of the domestic first Ethernet-based industrial automation protocol standards (Ethernet for Plant Automation, EPA). As a result, serial products are composed of configuration, control software, embedded software, control system, instrument chip to the

OEM board, and make Microcyber be an industrial automation products provider in full range, and also further Microcyber’s leading position in the field of fieldbus technology.

Microcyber is the FF member, the HART member and the Profibus National Organization (PNO) member.

Microcyber passes the Authentication of ISO 9001 Quality System, and has an outstanding innovative R&D team, plentiful practical experiences of design of the Automatic engineering, a leading product series, a huge market network, a strict quality management system and an excellent enterprise culture. All these further a solid foundation of entrepreneurship and sustainable development for Microcyber.

Carrying the ideals of employees, creating customer value and promoting enterprise development.

Microcyber is making progress with China.

Catalogue

1. BRIEF INTRODUCTION	1
2. INSTALLATION	2
2.1 DIMENSION	2
2.2 INSTALLATION	2
2.3 WIRING	3
3. HART TEMPERATURE TRANSMITTER CONFIGURATION	4
3.1 TOPOLOGY CONNECTION	4
3.2 FUNCTIONAL CONFIGURATION	5
4 MAINTENANCE	16
5 TECHNICAL SPECIFICATION	17
1.1 BASIC PARAMETER	17
1.2 RTD PARAMETER	18
1.3 THERMOCOUPLE	18
1.4 PHYSICAL PARAMETER	19

1. BRIEF INTRODUCTION

NCS-TT106H-V2.0 fieldbus temperature transmitter, using the fieldbus technology, is a new generation of smart fieldbus temperature transmitter and it is an indispensable field device for process control. NCS-TT106H-V2.0 integrates abundant function blocks and realizes not only general measurement function but also complicated control strategy.

NCS-TT106H-V2.0 uses digital technology, so it can connect with many types of thermocouple and thermo resistive sensors. It has wide range and simple interface between field and control room, which reduces the expense of installation, operation and maintenance.

NCS-TT106H-V2.0 fieldbus temperature transmitter supports HART, FF, and PA protocols. It can be widely used in the petroleum, chemicals, electricity, and metallurgical industries, etc.

2. INSTALLATION

2.1 Dimension

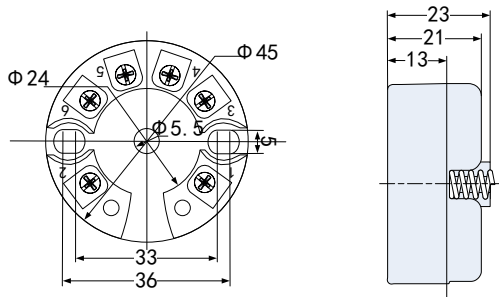

Figure 2.1 Dimension of Temperature Transmitter (Unit: mm)

2.2 Installation

Via positioning hole, use two screws to install the temperature module to temperature housing or rail.

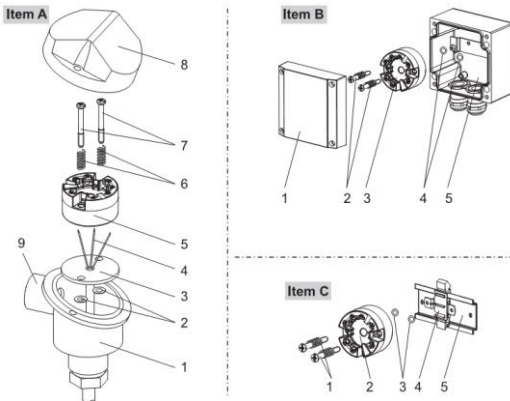

Figure 2.2 Installation

2.3 Wiring

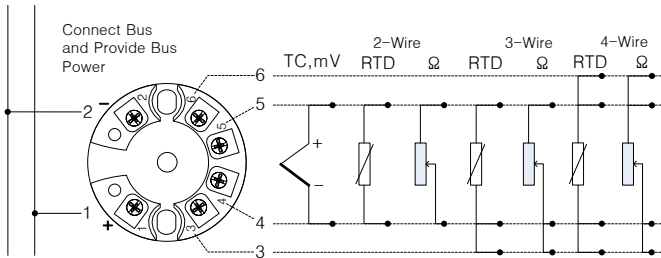

Figure 2.3 Wiring

Fieldbus temperature transmitter power and bus signal share a pair of cable, and it is called bus cable. It is suggested the user use fieldbus special cable recommended by IEC61158-2.

The signal cable and bus cable cannot share wires or wire slot with other device power wire, and they shall be away from device with high power.

The shielded wires of bus ends shall be connected to the ground.

3. HART TEMPERATURE TRANSMITTER CONFIGURATION

3.1 Topology Connection

The connection mode of HART smart transmitter can be divided into 4~20mA compatible mode and networking mode.

4~20mA compatibility mode (as shown in Figure 3.1)



Figure 3.1 4~20mA compatible mode

Features:

- 1) Access to the upper level control system through the AI module and HART communication device;
- 2) Mixed use of analog and digital communication methods;
- 3) The device address is 0.

Networking mode (as shown in Figure 3.2)



Figure 3.2 HART Networking mode

Features:

- 1) Access to the upper level control system through the HART communication device;
- 2) Using only the digital function of the HART system, the current on the line is fixed at 4 mA;
- 3) Supports up to 64 device networking in short address format.

3.2 Functional configuration

The intelligent temperature transmitter supports Microcyber Corporation's HartMPT configuration software, HART FCG's SDC625 and other general HART configuration software for configuration debugging. The following is an example of Microcyber's HartMPT configuration software to introduce the configuration method of the intelligent temperature transmitter. It mainly includes the following functions:

- 1) Basic information configuration: configure the basic information of the online device, including the label, address, date, assembly number and other information;

2) Configuration information configuration: configure the configuration information of the online device, including the main variable range, damping and other information;

3) Sensor information configuration: configure sensor information of the online device, including type, line system and other information;

4) Current calibration: It can calibrate the 4~20mA current of the online device, and can also set the fixed current output;

5) Variable monitoring: It can periodically refresh all dynamic variables of the selected online device and display the trend curve of the current device host variable.

- **Configuration environment**

1) PC with serial port, operating system is Windows 2000\Windows XP;

2) HART Modem and serial cable;

3) Matching resistance is $250\Omega \sim 550\Omega$.

- **Basic information configuration**

The basic information tab allows you to read or modify the basic information of the smart transmitter, including device address, message, description, label, date, assembly number, alarm, write protection, manufacturer ID, manufacturer, device type, device ID. , long address and version information, as shown in Figure 3.3.

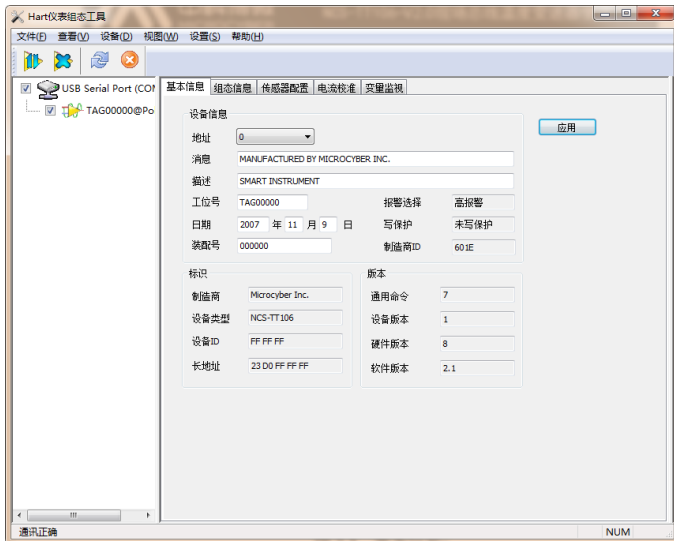

Figure 3.3 Basic Information

After the information is modified, you can download it to the device by pressing the “Apply” button.

- 1) The selection range of the address is 0 to 63;
- 2) The message can be entered up to 32 characters;
- 3) Description can input up to 16 specified characters;
- 4) The maximum length of the label is 8 specified characters;
- 5) The date range is from 1900 to 2155;
- 6) The maximum length of the assembly number is 6 specified characters.

● Configuration information configuration

The smart transmitter configuration information can be read or modified via the configuration information tab.

Including display device output variables (main variable, cold junction temperature value, current value, percentage), setting of main variable information (damping value, unit, range upper limit, range lower limit), calibration of range and alarm current Settings, etc., as shown in Figure 3.4.

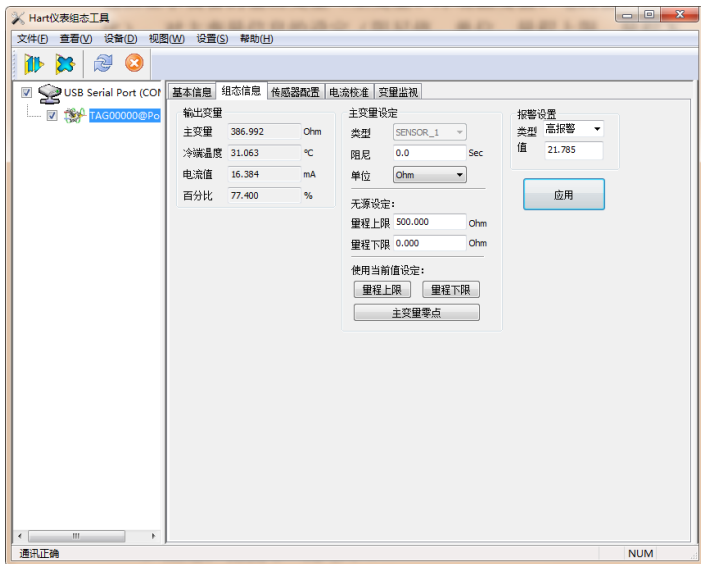

Figure 3.4 Configuration information

- Damping: Range 0 to 32 seconds.
- Unit: The change of PV unit directly affects the variables associated with the unit, such as the upper and lower limits of the range, the upper and lower limits of the sensor, and so on. When modifying the unit, you cannot modify the upper and lower limits of the main variable range at the same time, and should be modified

separately.

- The unit can be set to: C, F, R, K, mV, Ohm.
- Upper range: PV value corresponding to 20mA output current.
- Lower range: PV value corresponding to 4mA output current.
- Alarm type: high alarm and low alarm.
- Alarm value: When the alarm type is high alarm, it can be 21.75mA to 23.00mA

The alarm current is set within the range; when the alarm type is low alarm, the alarm current can be set within the range of 3.50mA to 3.75mA.

After the information is modified, you can download it to the device by pressing the “Apply” button.

- Set the “Range Upper Limit” button with the current value: set the current PV value of the device to the upper limit of the main variable range, and the lower limit of the range.
- Set the “Lower Limit” button with the current value: Set the current PV value of the device to the lower limit of the main variable range, which may change the upper limit at the same time.
- Set the “Main Variable Zero” button with the current value: Use the current PV value of the device as the main variable zero.

● **Sensor configuration**

The sensor information tab allows you to view the currently configured sensor information (upper, lower, and minimum spans) and to configure each sensor type, line, and other information. As

shown in Figure 3.5.

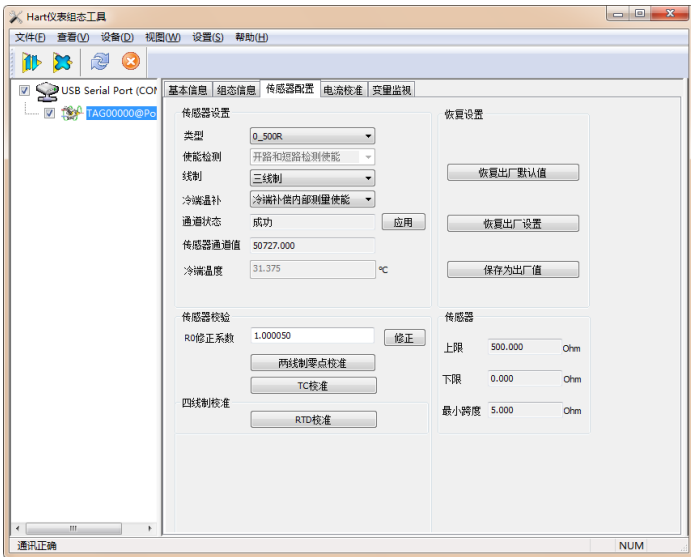

Figure 3.5 Sensor configuration

➤ Sensor type: supported sensor models are as below:

Sensor type	Description
0_500R	Resistance, 0 ~ 500Ω
0_4000R	Resistance, 0 ~ 4000Ω
CU50	Cu50
CU100	Cu100
PT100	PT100
PT1000	PT1000
100MV	mV voltage signal, range: -100 ~ 100 mV
B_TC	B thermocouple

E_TC	E thermocouple
J_TC	J thermocouple
K_TC	K thermocouple
N_TC	N thermocouple
R_TC	R thermocouple
S_TC	S thermocouple
T_TC	T thermocouple

- Wiring system: It can be set to 2-wire system, 3-wire system and 4-wire system, only effective for RTD.
- Cold-end temperature compensation: it can be set to prohibit, internal measurement and external measurement. When the cold-end temperature compensation is prohibited, the transmitter will not carry out the cold-end temperature compensation; when the cold-end temperature compensation is enabled to measure internally, the value of the cold-end temperature compensation is measured by the internal temperature measuring chip; when the cold-end temperature compensation is enabled to measure externally, the external two-wire system Pt100 is used, and then the value of the cold-end temperature compensation is measured by the external Pt100.
- Channel status: Display sensor channel status (open circuit, short circuit & etc.).
- Sensor channel value: Display the original value of sensor channel.
- Cold end temperature: Display the current cold end temperature.

- R0 Correction Factor: Correction of the error of the sensor itself (range 0.9-1.1).
- Two-wire zero calibration: When the temperature transmitter is connected to RTD in 2-wire mode, to avoid the error caused by the resistance on the cable, the sensor end can be short connected, and then the zero calibration button can be executed to eliminate the error caused by the resistance on the cable.
- TC Calibration: Calibration of various thermocouple ranges of transmitters is carried out in the factory (only applicable to manufacturer-level users).
- RTD calibration: All kinds of resistance ranges of transmitter are calibrated out of the factory (only for manufacturer-level users).
- Restore factory default value: Click this button, all data will be restored to the default factory status.
- Save as factory value: Click this button to save the current configuration as factory value. When you click the “Restore factory settings” button again, the saved configuration will be restored.
- Restore factory settings: Click this button to restore data to factory status. If the user has saved the factory value, the configuration saved by the user will be restored; otherwise, the default factory status will be restored.

- **Current Calibration**

The current calibration steps are as follow:

- 1) To connect the circuit, more than five and a half bits

ammeter should be connected in series in the output circuit of the equipment.

2) Set the polling address of the device to be 0. Refer to the basic information configuration. If the polling address is 0, you can skip this step.

3) Enter the current calibration tab;

4) Select the current value as 4mA. After the ammeter is stable, input the ammeter reading in the text box of “Adjustment Value” and click the “Application” button.

5) Select the “current value” of 20 mA. After the ammeter is stabilized, enter the ammeter reading in the “adjustment value” text box and click the “application” button.

6) Select "current value" as blank, so that the output current of the equipment is calculated according to PV value.

Configuration current fixed output:

Users can configure a fixed current output in the current calibration tab, click the given fixed current value or “Manual Send” and fill in the fixed current value to be output, click “Enter/Exit Fixed Current Mode” to enter or exit the fixed current output mode. The title of the button alternately displays “Enter Fixed Current Mode” and “Exit Fixed Current Mode” to prompt the user to operate.

HART intelligent transmitter continuously compares main variable value with the upper and lower limit value. When main variable value exceeds the upper and lower limit, the module outputs fixed current, indicating that the main variable exceeds the range. When the main variable is higher than the upper limit, the output is fixed at 20.8 mA. When it’s lower than the lower limit, the

output is fixed at 3.8 mA.

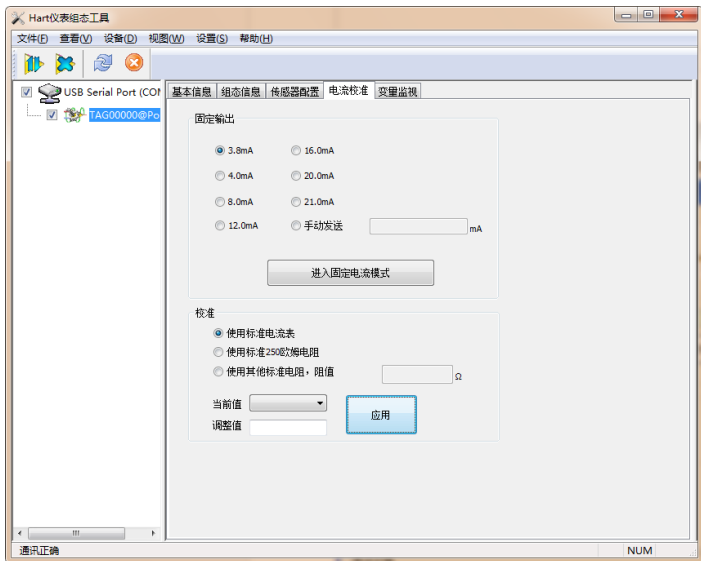

Figure 5.1 Current calibration

Note: Calibration current and fixed current output function can only be performed when device's polling address is 0. Other polling addresses are in complete digital communication mode, which will prompt the error message "command execution failure".

- **Variable monitoring**

Through the variable monitoring tab, all dynamic variables of the selected equipment can be refreshed regularly and the trend curve of the main variables of the current equipment can be displayed. Currently, the refreshed variables are PV value, current value, percentage and cold end temperature.

Figure 5.2 Variable monitoring

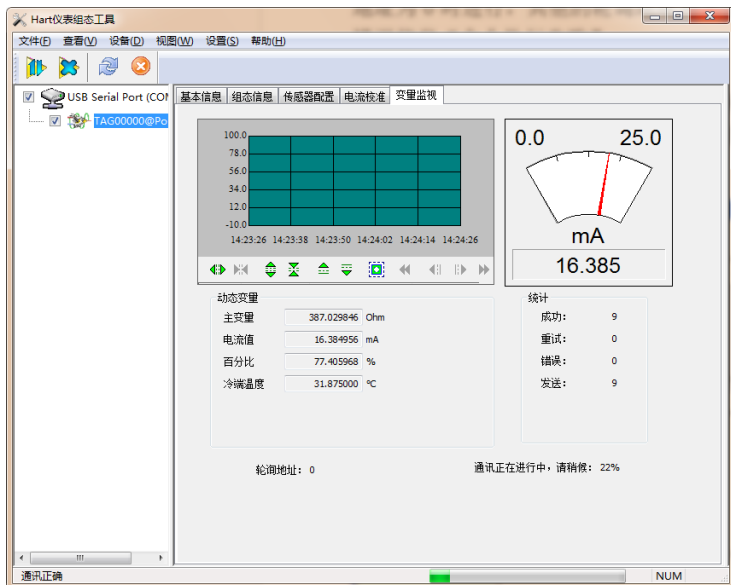

4 MAINTENANCE

Phenomenon	Solution
No communication	<p>Temperature Module Connection</p> <p>Check the bus cable connection</p> <p>Check bus power polarity</p> <p>Check bus cable shield, whether it is single point earthing or not</p>
	<p>Temperature Module Failure</p> <p>Replace the temperature module with others for testing.</p>
Reading Error	<p>Temperature Module Connection Failure</p> <p>Check sensor short circuit, open circuit, and earthing.</p> <p>Check sensor</p>
	<p>Noise Disturb</p> <p>Adjust damping</p> <p>Check the house earthing</p> <p>Check if the terminal is moist</p> <p>Check the cable is away from the strong electromagnetic interference</p>
	<p>Software Configuration</p> <p>Check sensor type configuration</p> <p>Check function block parameter configuration</p>
	<p>Software Configuration</p> <p>Check sensor type configuration</p> <p>Check function block parameter configuration</p>

5 TECHNICAL SPECIFICATION

1.1 Basic Parameter

Input Signal	Pt100、Pt1000、CU50、CU100、0~500Ω、0~4000Ω B, E, J, N, K, R, S, T eight kinds of Thermocouple -100mV~100mV voltage signal
Channel	Single
RTD Wiring	2-wire, 3-wire, 4-wire
Bus Power	HART: 11~35 VDC
Bus Signal	HART, current mode
Electric isolation	1000VAC
Working Temperature	-40℃~85℃
Humidity Range	5%~95%RH
Start Time	≤5s
Refresh Time	0.5s
EMC	GB/T 18268.1-2010
Protection	Terminal IP00, housing IP40
Voltage effect	±0.005%/V
Alarm signal	Alarm output can be set as 3.5...23 mA Upper/lower limit current 20.8mA / 3.8mA
Current accuracy	0.03%

1.2 RTD Parameter

● RTD Parameter at Normal Temperature

Signal type	Suggested range	Accuracy (25℃)	Temperature drift (per ℃)
Resistance	0~500Ω	±0.04Ω	±0.001Ω
Signal	0~4000Ω	±0.35Ω	±0.015Ω
PT100	-200 ~ 850℃	±0.15℃	±0.003℃
PT1000	-200 ~ 850℃	±0.15℃	±0.005℃
CU50	-50 ~ 150℃	±0.15℃	±0.005℃
CU100	-50~ 150℃	±0.10℃	±0.003℃

● RTD Other Parameter

Wiring	2、3、4
Common Mode Rejection	≥70dB (50Hz and 60Hz)
Series Mode Rejection	≥70dB (50Hz and 60Hz)

1.3 Thermocouple

● Thermocouple Parameter at Normal Temperature

Signal type	Suggested range	Accuracy (25℃)	Temperature drift (per ℃)
mV	-100mV ~ +100mV	±0.025mV	±0.001 mV
B	500 ℃~ 1810℃	±0.77℃	±0.050℃
E	-200 ℃~ 1000℃	±0.20℃	±0.025℃
J	-190 ℃~ 1200℃	±0.35℃	±0.01℃
K	-200℃ ~ 1372℃	±0.40℃	±0.025℃
N	-190℃ ~ 1300℃	±0.50℃	±0.015℃

R	0°C ~ 1768°C	±0.75°C	±0.023°C
S	0 °C~ 1768°C	±0.70°C	±0.023°C
T	-200°C ~ 400°C	±0.35°C	±0.015°C

● **Thermocouple Other Parameter**

Compensation Accuracy	±0.5°C
Sensor Type	B, E, J, N, K, R, S, T; -100mV~+100mV
Common Mode Rejection	≥70dB (50Hz and 60Hz)
Series Mode Rejection	≥70dB (50Hz and 60Hz)
Temperature Effect	<50ppm/°C

1.4 Physical Parameter

Dimension	ç45*23mm
Housing Material	Nylon



M i c r o c y b e r C o r p o r a t i o n

H t t p : / / w w w . m i c r o c y b e r . c n / e n

**A d d : 17-8 Wensu Street, Hunnan New District,
Shenyang, China 110179**

Tel: 0086-24-31217278 / 31217280

Fax: 0086-24-31217293

Email: sales@microcyber.cn