

JET®

GODETS D'ÉLÉVATEUR
ELEVATOR BUCKETS



STIF

components for your success

- ▶ Français
- ▶ English



Créée en 1984, S.T.I.F s'est créé une solide réputation de spécialiste du composant pour le vrac et plus particulièrement du godet d'élévateur en créant la gamme JET "ORIGINAL". Dès 1989, le godet JET a révolutionné le monde de l'élévation en apportant une solution fiable et économique pour tous les produits, avec des vitesses faibles ou élevées dans toutes les INDUSTRIES: Agro alimentaires, silos UAB, moulins..., Industries lourdes, Installations portuaires. En quelques années, la gamme JET est devenue incontournable dans de nombreux pays.

Ce catalogue vous présente tous les modèles de la gamme.

Established in 1984, S.T.I.F has built up a well established reputation as specialists in components for bulk handling products, particularly elevator buckets, by creating the "original" JET range. Since 1989, the JET elevator bucket has revolutionized the elevation sector by providing a reliable, economical solution for all slow and fast-flowing products, in all INDUSTRIES: Agri-food, UAB silos, mills..., heavy industry, port facilities.

In just a few years, the JET product range has made itself indispensable in numerous countries. This catalogue features all the models in the range.



les composants de votre réussite

Z.A. de la Lande — 49170 Saint-Georges-sur-Loire — FRANCE — Tél.: +33 2 41 72 16 82 — Fax: +33 2 41 39 32 12
E mail: sales@stifnet.com — Web: www.stifnet.com

JET®

- Conçu pour répondre à tous les produits courants avec des vitesses faibles ou rapides.
- Godet version acier embouti de forte épaisseur; très longue durée de vie et résistance optimale garantie. (ép. de 1 à 4 mm acier ou inox)
- Godet version polymères de très haute qualité (HDPE; PA 6 nylon; PU; HDPE Atex) garantissant une longue durée de vie et une excellente résistance.
- Adapté à tous produits.
- Designed for use with all slow or fast-flowing products.
- Thick pressed steel bucket version, extended lifespan and optimal resistance guaranteed. (1 to 4 mm thick steel or stainless steel)
- Very high-quality polymer bucket version (HDPE; PA 6 nylon; PU; HDPE Atex) guaranteeing an extended lifespan and excellent resistance.
- Suitable for all products.

EUROJET®

- Conçu pour répondre aux produits à écoulement difficile.
- Godet version acier embouti de forte épaisseur; longue durée de vie et bonne résistance garanties. (ép. de 1 à 3 mm acier ou inox)
- Godet version polymères de très haute qualité (HDPE; PA 6 nylon; PU; HDPE Atex) garantissant une bonne durée de vie et une bonne résistance.
- Particulièrement adapté aux vitesses très faibles et très rapides.
- Designed for use with difficult-flowing products.
- Thick pressed steel bucket version, extended lifespan and optimal resistance guaranteed. (1 to 2.5 mm thick steel or stainless steel)
- Very high-quality polymer bucket version (HDPE; PA 6 nylon; PU; HDPE Atex) guaranteeing an extended lifespan and excellent resistance.
- Particularly suitable for very low and very high-speed flows.

JETCC®

- Profond, de grande capacité.
- Conçu pour répondre aux produits coulant à vitesses moyennes et rapides.
- Godet version polymères de très haute qualité (HDPE; PA 6 nylon; PU; HDPE Atex) garantissant une bonne durée de vie et une bonne résistance.
- Particulièrement adapté aux céréales.
- Deep-bottomed with high capacity.
- Designed for use with products flowing at average and high speeds.
- Very high-quality polymer bucket version (HDPE; PA 6 nylon; PU; HDPE Atex) guaranteeing an extended lifespan and excellent resistance.
- Particularly suitable for grain.

JET-R®

- Profond, de grande capacité et de très bonne durée de vie.
- Avec ses angles arrondis, conçu pour répondre aux produits coulants à vitesse lente et moyenne.
- Godet version acier embouti de 1,5 d" épaisseur et godet inox de 1 à 1,5 mm.
- Particulièrement adapté au riz et céréales sèches.
- Deep-bottomed with high capacity.
- With round angles, designed for use with products flowing at average and high speeds.
- Thick pressed steel bucket version, very long lifespan and good resistance. (1,5 mm thick steel and 1 to 1,5 mm thick stainless steel)
- Suitable for rice and dry cereal

SILOJET®

- Profond, de grande capacité.
- Conçu pour répondre aux produits coulant à vitesses moyennes et rapides.
- Godet version acier embouti de forte épaisseur très bonne durée de vie et une bonne résistance. (ép. de 1 à 2,5 mm acier et inox)
- Convient pour la rénovation silo céréales.
- Deep-bottomed with high capacity.
- Designed for use with products flowing at average and high speeds.
- Thick pressed steel bucket version, very long lifespan and good resistance. (1 to 2.5 mm thick steel and stainless steel)
- Cereal suits for the renovation of silo.

Columbus DIN 15232

- Conçu pour répondre aux produits coulant à vitesses moyennes
- Version acier embouti de forte épaisseur; bonne durée de vie et une bonne résistance. (ép. de 1 à 2,5 mm acier)
- Godet version polymères de très haute qualité (HDPE; PA 6 nylon; PU; HDPE Atex) garantissant une bonne durée de vie et une bonne résistance
- Adapté aux céréales et granuleux
- Designed for use with products flowing at average speeds.
- Thick pressed steel bucket version, highly durable and resistant (1 to 2.5 mm thick steel)
- Very high-quality polymer bucket version (HDPE; PA 6 nylon; PU; HDPE Atex) guaranteeing an extended lifespan and excellent resistance.
- Suitable for grain and granular products.

BOLJET® - SUPERBOLJET®

- Godet version polymères de très haute qualité (HDPE; PA 6 nylon; PU; HDPE Atex) garantissant une bonne durée de vie et une bonne résistance
- Particulièrement adapté aux semences.
- Designed for use with brittle products flowing at low and average speeds.
- Very high-quality polymer bucket version (HDPE; PA 6 nylon; PU; HDPE Atex) guaranteeing an extended lifespan and excellent resistance.
- Particularly suitable for seeds.



JET®

GODET D'ÉLEVATEUR / ELEVATOR BUCKET

SOMMAIRE

SUMMARY

JET®
Acier - Steel

P.6

JET®
HDPE/PA6/PU/HDPE Z20

P.7

EUROJET®
Acier - Steel

P.8

EUROJET®
HDPE/PA6/PU/HDPE Z20

P.9

JETCC®
HDPE/PA6/PU

P.10/11

JET-R® MAXIJET®
Acier - Steel

P.12

SILOJET®
Acier - Steel

P.13

Columbus
Acier - Steel
HDPE/PA6/PU/HDPE Z20

P.14

BOLJET®- SUPERBOLJET®
HDPE/PA6/PU/HDPE Z20

P.15

NORMAJET®
Acier - Steel

P.16

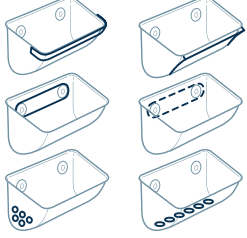
Options

P.16

Jonction & Boulonnerie
Junction & Bolt

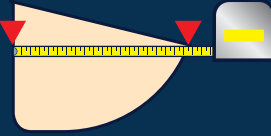
P.17

Comment mesurer un godet ?
How to measure a bucket?

P.18

STIF
C'est aussi :
Sangles
Appareil de sécurité
Events d'explosion
It's also :
Elavator belt
Safety equipment
Explosion vent panel
P.19



GUIDE CHOIX MATIÈRE HOW TO CHOOSE OUR MATERIAL

MATERIAUX MATERIALS	Acier Steel	Inox 304L Stainless Steel 304L	Inox 316L Stainless Steel 316L	HDPE	PA 6 PA 6/6*	PU	HDPE Z20
LONGEVITE LONGEVITY	***	****	****	*	***	***	*
PRODUITS COLLANTS STICKY PRODUCTS	***	***	***	*	***	***	*
TENUE A L'IMPACT IMPACT PERFORMANCE	*	***	***	**	***	***	**
ALIMENTAIRE FOOD GRADE	X	✓	✓	✓	✓	✓	X
TEMPERATURE °C EN CONTINU CONTINUOUS TEMPERATURE °C	180°C	250°C	250°C	70°C	100°C 120°C*	70°C	70°C
TEMPERATURE °C EN POINTE TOP TEMPERATURE °C	200°C	400°C	400°C	80°C	120°C 130°C*	80°C	80°C
RESISTIVITE RESISTIVITY	✓ Conducteur Conductor	✓ Conducteur Conductor	✓ Conducteur Conductor	X Isolant Insulator	X Isolant Insulator	X Isolant Insulator	✓ Dissipateur < 1 Gohms Dissipating < 1 Gohms
PRIX PRICE	*	***	****	*	***	****	****
COULEUR COLOUR	-	-	-	Blanc White	Crème Cream	Vert Green	Crème Cream
DENSITÉ DENSITY	7,85	7,85	7,85	0,96	1,14	1,19	0,96
APPLICATIONS APPLICATIONS	<ul style="list-style-type: none"> • Céréales • Industrie <ul style="list-style-type: none"> • Cereals • Industry 	<ul style="list-style-type: none"> • Alimentaire • Corrosion • Température <ul style="list-style-type: none"> • Food • Corrosion • Temperature 	<ul style="list-style-type: none"> • Alimentaire • Forte Corrosion <ul style="list-style-type: none"> • Food • High Corrosion 	<ul style="list-style-type: none"> • Céréales • Alimentaire <ul style="list-style-type: none"> • Cereals • Food 	<ul style="list-style-type: none"> • Température • Abrasion • Collant • Alimentaire <ul style="list-style-type: none"> • Temperature • Abrasion • Sticky • Food 	<ul style="list-style-type: none"> • Température • Coupant • Collant <ul style="list-style-type: none"> • Temperature • Sharp • Sticky 	<ul style="list-style-type: none"> • Céréales • Alimentaire <ul style="list-style-type: none"> • Cereals • Food

* Sur demande - On request



ACIER EMBOUTI

Céréales - Produits légers - Pellets - Produits collants - Produits industriels

PRESSED STEEL - Cereals - Light materials - Pellets - Sticky materials - Industrial materials

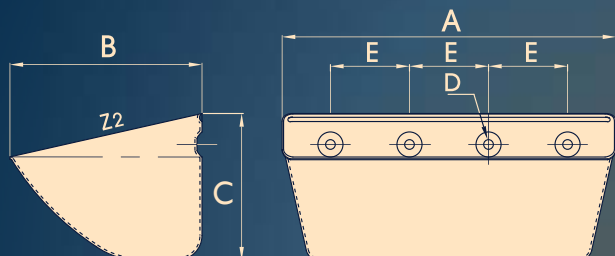

N°	A mm	B mm	C mm	Trous/Holes			Capacité / Capacity		Godets / Buckets /mtr	Poids / Weight Kg							
				Nbr	D mm	E mm	Z2 (c)	Z1 (c)		1,0 mm	1,2 mm	1,5 mm	2,0 mm	2,5 mm	3,0 mm	4,0 mm	
JET 08-080	85	80	58	2	8	43	0,21	0,18	15	0,11							
JET 10-090	105	92	70	2	8	50	0,38	0,26	14	0,15							
JET 12-100	125	103	80	2	8,50	67	0,62	0,45	11,50		0,27						
JET 13-120	138	125	90	2	8,50	70	0,77	0,65	10,50				0,40				
JET 14-120	146	120	90	2	8,50	70	0,87	0,71	10,50				0,40				
JET 15-140	154	140	108	2	9	70	1,25	0,95	8,50				0,54				
JET 18-140	188	141	110	2	9	100	1,65	1,26	8,50				0,65				
JET 20-140	207	142	110	2	9	100	1,79	1,37	8,50				0,73				
JET 22-140	227	142	110	2	9	120	2,00	1,58	8,50				0,77				
JET 23-140	237	142	110	2	9	120	2,08	1,60	8,50				0,81				
JET 20-160	205	169	132	2	11	100	2,60	2,03	7,40				1,18				
JET 23-160	235	169	132	2	11	120	3,00	2,40	7,40				1,33				
JET 24-160	245	169	132	2	11	140	3,18	2,46	7,40				1,41				
JET 26-160	265	169	132	3	11	80	3,50	2,80	7,40				1,50				
JET 28-160	285	169	132	3	11	80	3,76	2,95	7,40				1,59				
JET 30-160	310	176	128	3	11	100	4,00	3,00	7,40				1,65				
JET 33-160	339	176	128	3	11	110	4,32	3,17	7,40				1,79				
JET 35-160	356	176	128	3	11	120	4,53	3,47	7,40				1,87				
JET 37-160	375	176	128	4	11	90	4,85	3,55	7,40				1,91				
JET 20-180	209	188	147	2	11	110	3,15	2,40	6,50				1,24				
JET 24-180	249	188	147	2	11	140	3,90	2,98	6,50				1,53				
JET 26-180	269	188	147	3	11	80	4,30	3,32	6,50				1,57				
JET 28-180	289	188	147	3	11	80	4,60	3,60	6,50				1,71				
JET 30-180	309	188	147	3	11	100	5,00	3,90	6,50				1,80				
JET 33-180	339	188	147	3	11	110	5,55	4,32	6,50				1,94				
JET 35-180	359	188	147	3	11	120	5,90	4,60	6,50				2,05				
JET 37-180	379	188	147	4	11	90	6,30	4,90	6,50						2,73		
JET 25-215	255	216	162	3	11	80	5,20	4,00	5,88				1,90				
JET 28-215	285	216	162	3	11	80	5,90	4,65	5,88				2,09				
JET 30-215	312	216	162	3	11	100	6,70	5,20	5,88				2,24				
JET 33-215	340	220	162	3	11	110	7,20	5,65	5,88						2,35		
JET 35-215	360	220	164	3	11	120	7,60	5,85	5,88						3,20		
JET 37-215	380	220	164	4	11	90	8,60	6,50	5,88						3,32		
JET 44-215	450	220	164	4	11	110	10,00	7,70	5,88						3,78		
JET 47-215	480	220	164	4	11	120	10,53	8,50	5,88						4,04		
JET 50-215	510	220	164	4	11	135	11,20	9,00	5,88						4,30		
JET 53-215	540	220	164	6	11	80	11,87	9,50	5,88						4,56	5,50	
JET 56-215	570	220	164	6	11	90	12,54	10,00	5,88						4,82	5,82	
JET 63-215	640	220	164	7	11	90	14,12	11,30	5,88						5,42	6,50	
JET 33-250	340	253	190	4	11	80	8,95	6,70	5							4,10	5,50
JET 35-250	360	253	190	4	11	80	9,50	7,30	5							4,35	5,80
JET 37-250	380	253	190	4	11	90	10,10	7,60	5							4,60	6,15
JET 42-250	430	253	190	5	11	80	11,50	8,70	5							5,25	7,00
JET 44-250	450	253	190	5	11	90	12,10	9,15	5							5,50	7,35
JET 47-250	480	253	190	5	11	90	13,00	9,75	5							5,80	7,75
JET 53-250	540	253	190	6	11	80	14,60	11,00	5							6,60	8,80
JET 56-250	570	253	190	6	11	90	15,35	11,60	5							6,95	9,30
JET 63-250	640	253	190	7	11	90	17,20	13,00	5							7,80	10,40

Utiliser vis tête fraisée à ergots (voir page 17) / Use countersunk lug bolt (see page 17)

MATIÈRE PLASTIQUE INJECTÉE HDPE/PA6/PU/HDPE Z20

Céréales - Produits légers - Pellets - Produits collants - Produits industriels

PLASTIC MATERIAL INJECTED HDPE/PA6/PU/HDPE Z20

Cereals - Light materials - Pellets - Sticky materials - Industrial materials

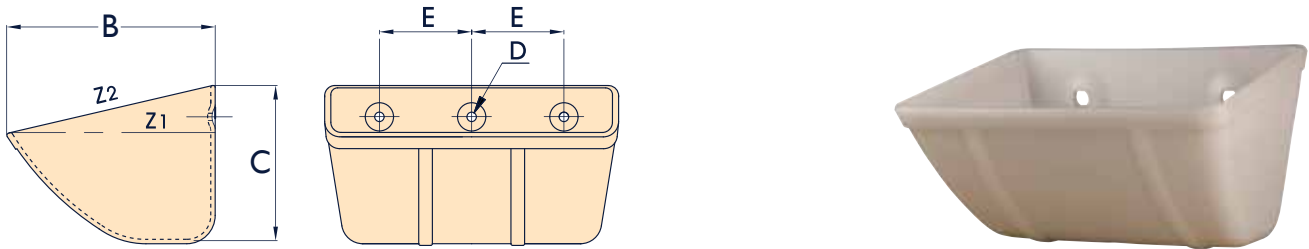

N°	A mm	B mm	C mm	Trous /Holes			Capacité/ Capacity		Godets / Buckets /mtr	Poids /Weight Kg		
				Nbr	D mm	E mm	Z2 (c)	Z1 (c)		HDPE	PA6	PU
JET 10-090	110	96	69	2	8	50	0,36	0,24	14	0,077	0,092	0,096
JET 13-120	139	130	85	2	8	70	0,80	0,51	11	0,143	0,171	0,178
JET 15-140	156	157	113	2	8,50	70	1,42	1,13	8,50	0,232	0,277	0,289
JET 18-140	189	157	113	2	8,50	100	1,77	1,37	8,50	0,273	0,326	0,341
JET 20-140	207	157	113	2	8,50	100	1,95	1,62	8,50	0,315	0,376	0,393
JET 22-140	228	152	112	2	8,50	120	1,93	1,49	8,50	0,320	0,382	0,399
JET 23-145	252	158	125	2	8,50	120	2,44	2,20	7	0,403	0,482	0,503
JET 20-170	214	180	129	2	11	110	2,50	1,94	7	0,389	0,465	0,485
JET 23-170	242	185	142	2	11	120	3,25	2,40	6,50	0,475	0,540	0,595
JET 28-170	291	185	140	3	11	80	4,03	3,00	6,50	0,554	0,665	0,690
JET 30-190	320	202	157	3	11	100	5,21	3,96	6	1,039	1,305	1,360
JET 30-215	325	229	170	3	11	100	6,53	4,99	5,50	1,114	1,367	1,427
JET 33-215	350	230	172	3	11	120	7,36	5,47	5,50	1,118	1,336	1,395
JET 35-215	370	230	172	3	11	120	7,66	5,72	5,50	1,127	1,347	1,406
JET 37-215	391	230	172	4	11	90	7,97	5,97	5,50	1,347	1,610	1,680
JET 40-215	421	230	172	4	11	100	8,78	6,78	5,50	1,518	1,814	1,894
JET 44-215	461	230	172	5	11	90	9,59	7,33	5,50	1,585	1,894	1,977
JET 50-215	528	230	172	5	11	100	10,95	8,19	5,50	1,808	2,161	2,255

Utiliser vis tête fraisée à ergots (voir page 17) / Use countersunk lug bolt (see page 17)



ACIER EMBOUTI

Céréales - Produits légers - Pellets - Produits collants - Produits industriels

PRESSED STEEL

Cereals - Light materials - Pellets - Sticky materials - Industrial materials

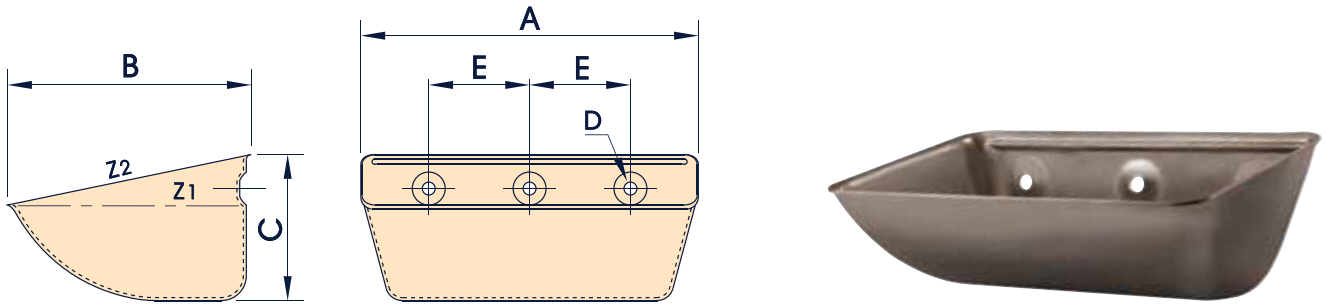

N°	A mm	B mm	C mm	Trous/Holes			Capacité/ Capacity		Godets/ Buckets /mtr	Poids/Weight Kg						
				Nbr	D mm	E mm	Z2 (°)	Z1 (°)		1,0 mm	1,2 mm	1,5 mm	2,0 mm	2,5 mm	3,0 mm	
EURO JET 10-090	105	93	66	2	8,50	50	0,35	0,25	14	0,15						
EURO JET 12-100	125	104	78	2	8,50	67	0,55	0,35	12		0,23					
EURO JET 13-120	135	115	81	2	8,50	70	0,65	0,45	12		0,28					
EURO JET 16-130	165	130	87	2	8,50	100	0,95	0,60	12			0,44				
EURO JET 18-140	185	140	92	2	8,50	100	1,29	0,90	10,5			0,55				
EURO JET 20-140	205	140	90	2	11	100	1,45	1,05	10,5			0,61				
EURO JET 23-165	238	165	110	2	11	120	2,45	1,73	9				1,18			
EURO JET 25-165	258	165	110	3	11	77	2,70	2,00	9				1,27			
EURO JET 28-165	288	165	110	3	11	80	3,00	2,25	9				1,40			
EURO JET 30-180	308	187	120	3	11	100	3,70	2,45	8,13				1,55			
EURO JET 30-215	308	215	140	3	11	100	5,20	3,65	7,14				1,94	2,40	2,90	
EURO JET 33-215	338	215	130	3	11	120	5,50	3,95	7,14				1,97	2,50	3,00	
EURO JET 37-215	378	215	130	4	11	90	6,20	4,10	7,14				2,25	2,86	3,45	
EURO JET 44-215	448	215	130	5	11	90	7,50	5,60	7,14				2,70	3,20	3,85	

Utiliser vis tête fraisée à ergots (voir page 17) / Use countersunk lug bolt (see page 17)

MATIÈRE PLASTIQUE INJECTÉE HDPE/PA6/PU/HDPE Z20

Céréales - Produits légers - Pellets - Produits collants - Industrie lourde

PLASTIC MATERIAL INJECTED HDPE/PA6/PU/HDPE Z20

Cereals - Light materials - Pellets - Sticky materials - Heavy industry

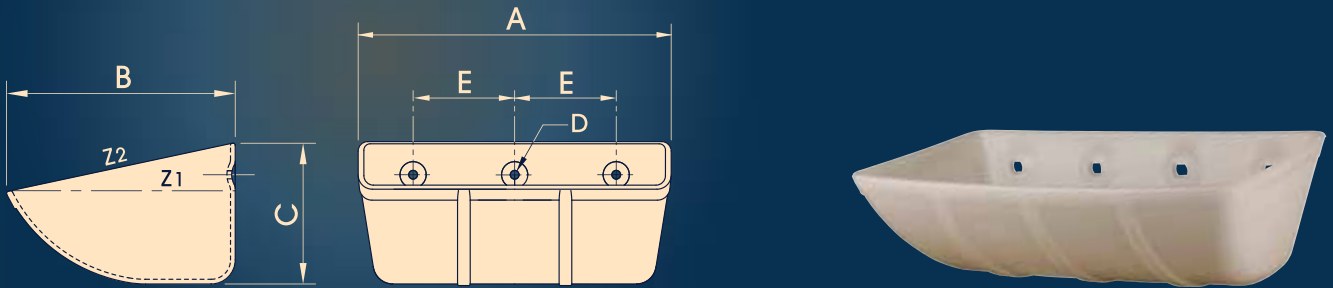

N°	A mm	B mm	C mm	Trous/Holes			Capacité/ Capacity		Godets/ Buckets /mtr	Poids/Weight Kg		
				Nbr	D mm	E mm	Z2 (e)	Z1 (e)		HDPE	PA 6	PU
EURO JET 10-090	110	97	69	2	8	50	0,33	0,24	14	0,077	0,092	0,096
EURO JET 13-120	145	122	83	2	8	70	0,69	0,46	11	0,126	0,151	0,157
EURO JET 15-120	160	131	85	2	8	80	0,94	0,60	11	0,156	0,186	0,195
EURO JET 18-140	188	149	93	2	8	100	1,20	0,84	10,5	0,264	0,315	0,329
EURO JET 20-165	207	176	115	2	11	100	2,17	1,67	9	0,361	0,431	0,450
EURO JET 23-165	242	172	117	2	11	120	2,42	1,60	9	0,380	0,454	0,474
EURO JET 28-165	292	170	116	3	11	80	2,90	2,00	9	0,459	0,548	0,573
EURO JET 30-180	318	186	135	3	11	100	4,04	2,97	8	0,766	0,915	0,955
EURO JET 33-215	339	222	145	3	11	120	4,44	3,19	7,14	0,746	0,891	0,931
EURO JET 37-215	383	219	142	4	11	90	6,06	4,20	7,14	0,822	0,982	1,025
EURO JET 44-215	455	223	143	5	11	90	7,39	4,59	7,14	1,148	1,372	1,432

Utiliser vis tête fraisée à ergots (voir page 17)/Use countersunk lug bolt (see page 17)



MATIÈRE PLASTIQUE INJECTÉE HDPE/PA6/PU/HDPE Z20

Céréales - Produits légers - Pellets - Produits industriels - Boulons = Vis tête plates

PLASTIC MATERIAL INJECTED HDPE/PA6/PU/HDPE Z20

Cereals - Light materials - Pellets - Industrial materials - Bolts = Lug bolts

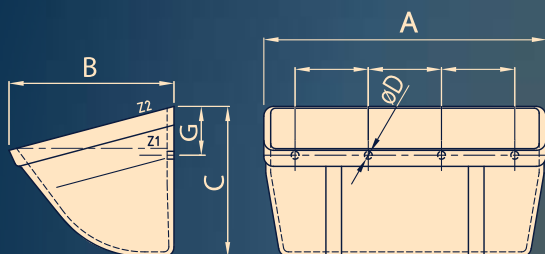

N°	A mm	B mm	C mm	Trous/Holes			Capacité/ Capacity		Godets / Buckets /mtr	Poids/Weight Kg				
				Nbr	D mm	E mm	G mm	Z ₂ (e)		Z ₁ (e)	HDPE	PA 6	PU	
JET CC 4x3	10/090	114	90	80	2	Ø 7	63	20	0,40	0,30	11,25	0,10	0,12	0,12
JET CC 5x4	13/100	138	115	100	2	Ø 7	80	30	0,75	0,61	8,75	0,17	0,20	0,21
JET CC 6x4	16/100	164	115	100	2	Ø 7	110	30	0,95	0,74	8,75	0,23	0,27	0,29
JET CC 7x4	18/100	186	115	100	3	Ø 7	68	30	1,13	0,87	8,75	0,26	0,31	0,32
JET CC 7x5	18/140	192	140	130	3	Ø 7	68	35	1,74	1,35	7,15	0,38	0,45	0,47
JET CC 8x5	20/140	216	140	130	3	Ø 7	78	35	2,00	1,56	7,15	0,37	0,44	0,46
JET CC 9x5	23/140	242	140	130	3	Ø 7	92	35	2,22	1,71	7,15	0,46	0,55	0,57
* JET CC 10x5	26/140	268	140	130	3	Ø 7	105	35	2,53	1,97	7,15	0,49	0,58	0,61
JET CC 8x6	20/170	215	170	155	3	Ø 7	78	45	2,90	2,10	6,00	0,54	0,64	0,67
JET CC 9x6	23/170	242	170	155	3	Ø 7	92	45	3,30	2,52	6,00	0,60	0,71	0,74
JET CC 10x6	26/170	266	170	155	3	Ø 7	105	45	3,70	2,75	6,00	0,64	0,76	0,79
JET CC 11x6	28/170	292	170	155	4	Ø 7	76	45	4,10	3,10	6,00	0,69	0,82	0,86
* JET CC 11x7	30/200	302	200	175	4	Ø 9	76	50	5,70	4,43	5,25	0,99	1,18	1,23
JET CC 12x7	32/200	326	200	175	4	Ø 9	86	50	6,18	4,79	5,25	1,20	1,43	1,49
JET CC 14x7	37/200	378	200	175	5	Ø 9	76	50	7,30	5,62	5,25	1,19	1,41	1,48
* JET CC 16x7	42/200	428	200	175	6	Ø 9	73	50	8,35	6,40	5,25	1,31	1,56	1,62
* JET CC 10x8	26/230	278	230	205	3	Ø 9	105	55	6,66	5,19	4,60	1,32	1,57	1,64
JET CC 11x8	30/230	302	230	205	4	Ø 9	76	55	6,90	5,88	4,60	1,41	1,67	1,75
* JET CC 12x8	32/230	328	230	205	4	Ø 9	86	55	8,30	6,29	4,60	1,51	1,79	1,87
JET CC 14x8	37/230	380	230	205	5	Ø 9	76	55	9,70	7,57	4,60	1,70	2,02	2,11
JET CC 16x8	42/230	430	230	205	6	Ø 9	73	55	11,10	8,66	4,60	1,90	2,26	2,36
JET CC 18x8	47/230	482	230	205	6	Ø 9	80	55	12,50	9,61	4,60	2,10	2,49	2,60
* JET CC 20x8	52/230	532	230	205	6	Ø 9	90	55	13,90	10,86	4,60	2,28	2,71	2,83
* JET CC 22x8	57/230	582	230	205	6	Ø 9	100	55	15,30	12,12	4,60	2,47	2,93	3,06

Utiliser vis tête plate à ergots (voir page 17) / Use flat lug bolt (see page 17)

* Disponible en 2013 / Available in 2013

Autre perçage sur demande / Other punching hole on request

MATIÈRE PLASTIQUE INJECTÉE HDPE/PA6/PU/HDPE Z20

Céréales - Produits légers - Pellets - Produits industriels - Boulons = vis tête plates

PLASTIC MATERIAL INJECTED HDPE/PA6/PU/HDPE Z20

Cereals - Light materials - Pellets - Industrial materials - Bolts = lug bolts

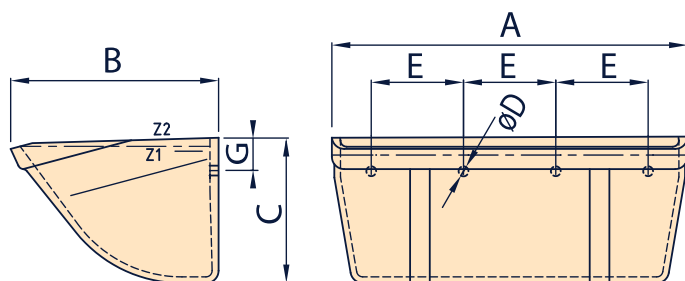

N°	A mm	B mm	C mm	Trous/Holes			Capacité/ Capacity		Godets/ Buckets /mtr	Poids/Weight Kg			
				Nbr	D mm	E mm	G mm	Z ₂ (e)		Z ₁ (e)	HDPE	PA 6	PU
JET CC 4x3	10/090	114	90	2	∅ 7	63	20	0,40	0,30	11,25	0,10	0,12	0,12
JET CC 5x4	13/100	138	115	2	∅ 7	80	25	0,65	0,61	11,25	0,15	0,18	0,19
JET CC 6x4	16/100	164	115	2	∅ 7	110	25	0,78	0,74	11,25	0,21	0,25	0,26
JET CC 7x4	18/100	186	115	3	∅ 7	68	25	0,92	0,87	11,25	0,24	0,29	0,30
JET CC 7x5	18/140	192	140	3	∅ 7	68	28	1,52	1,35	8,50	0,33	0,39	0,41
JET CC 8x5	20/140	216	140	3	∅ 7	78	28	1,74	1,56	8,50	0,32	0,38	0,40
JET CC 9x5	23/140	242	140	3	∅ 7	92	28	1,94	1,71	8,50	0,40	0,48	0,50
* JET CC 10x5	26/140	268	140	3	∅ 7	105	28	2,21	1,97	8,50	0,43	0,51	0,53
JET CC 8x6	20/170	215	170	3	∅ 7	78	30	2,38	2,10	7,50	0,47	0,56	0,58
JET CC 9x6	23/170	242	170	3	∅ 7	92	30	2,70	2,52	7,50	0,53	0,63	0,66
JET CC 10x6	26/170	266	170	3	∅ 7	105	30	3,05	2,75	7,50	0,56	0,67	0,69
JET CC 11x6	28/170	292	170	4	∅ 7	76	30	3,35	3,10	7,50	0,60	0,71	0,74
* JET CC 11x7	30/200	302	200	4	∅ 9	76	32	4,85	4,43	6,50	0,90	1,07	1,12
JET CC 12x7	32/200	326	200	4	∅ 9	86	32	5,25	4,79	6,50	1,05	1,25	1,30
JET CC 14x7	37/200	378	200	5	∅ 9	76	32	6,20	5,62	6,50	1,08	1,28	1,34
* JET CC 16x7	42/200	428	200	6	∅ 9	73	32	7,09	6,40	6,50	1,18	1,40	1,46
* JET CC 10x8	26/230	278	230	3	∅ 9	105	35	5,66	5,19	5,50	1,22	1,45	1,51
JET CC 11x8	30/230	302	230	4	∅ 9	76	35	5,90	5,88	5,50	1,30	1,54	1,61
* JET CC 12x8	32/230	328	230	4	∅ 9	86	35	7,10	6,29	5,50	1,38	1,64	1,71
JET CC 14x8	37/230	380	230	5	∅ 9	76	35	8,30	7,57	5,50	1,56	1,85	1,93
JET CC 16x8	42/230	430	230	6	∅ 9	73	35	9,50	8,66	5,50	1,74	2,07	2,16
JET CC 18x8	47/230	482	230	6	∅ 9	80	35	10,70	9,61	5,50	1,92	2,28	2,38
* JET CC 20x8	52/230	532	230	6	∅ 9	90	35	11,90	10,86	5,50	2,08	2,47	2,58
JET CC 22x8	57/230	582	230	6	∅ 9	100	35	13,10	12,12	5,50	2,26	2,68	2,80

Utiliser vis tête plate à ergots (voir page 17) / Use flat lug bolt (see page 17)

* Disponible en 2013 / Available in 2013

Autre perçage sur demande / Other punching hole on request

JET-R®

ACIER EMBOUTI

Céréales - Riz

PRESSED STEEL

Cereals - Rice

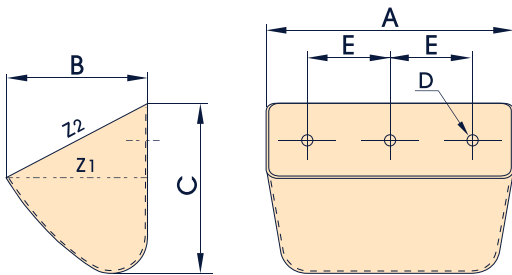

N°	A mm	B mm	C mm	Trous/Holes			Capacité/Capacity		Godets/ Buckets /mtr	Peso / Kg	
				Nbr	D mm	E mm	Z2 (e)	Z1 (e)		1,5 mm	
JET-R 5x4	14/100	141	105	121	2	8	88	0,90	0,54	7	0,36
JET-R 7x4	18/100	181	105	121	2	8	113	1,15	0,71	7	0,43
JET-R 6x5	15/135	151	139	155	2	8	78	1,55	0,90	6	0,70
JET-R 7x5	18/135	181	139	155	3	8	68	1,94	1,15	6	0,81
JET-R 9x5	23/135	231	139	155	3	8	78	2,65	1,65	6	0,93
JET-R 11x5	28/135	282	140	155	3	8	102	3,17	1,91	6	1,56

Utiliser vis tête plate à ergots (voir page 17) / Use countersunk lug bolt (see page 17)

Autre perçage sur demande / Other punching hole on request

MAXIJET®

ACIER EMBOUTI

Céréales - Pellets - Produits collants

PRESSED STEEL

Cereals - Pellets - Sticky materials

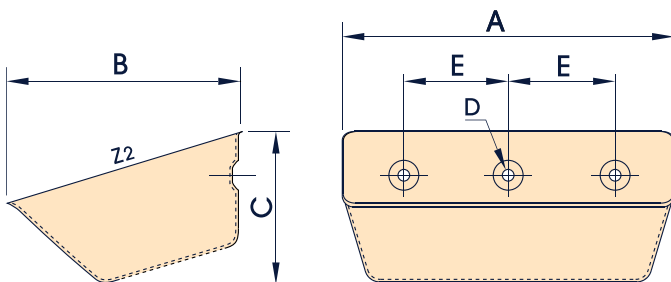

N°	A mm	B mm	C mm	Trous/Holes			Capacité/ Capacity	Godets/ Buckets /mtr	Poids/Weight Kg		
				Nbr	D mm	E mm			Z2 (e)	1,0 mm	1,5 mm
MJX 10-090	105	90	57	2	8,50	40	0,24	20	0,10		
MJX 13-120	134	115	67	2	8,50	70	0,45	18,50		0,23	
MJX 18-140	185	139	90	2	8,50	100	1,15	14		0,45	
MJX 23-165	238	164	102	2	8,50	120	1,95	12,50			0,84
MJX 28-165	290	167	108	3	8,50	90	2,89	11,40			1,08

Utiliser vis tête fraisée à ergots (voir page 17) / Use countersunk lug bolt (see page 17)

Document non contractuel - Non contractual document



ACIER EMBOUTI

Céréales - Produits légers - Pellets

PRESSED STEEL

Cereals - Light materials - Pellets

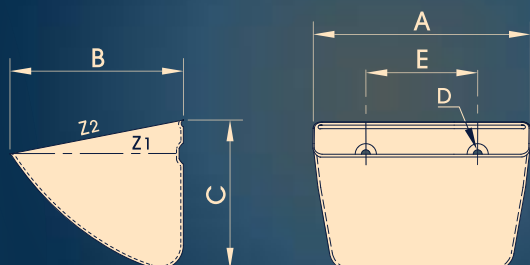

N°	A mm	B mm	C mm	Trous/Holes			Capacité/Capacity		Godets/Buckets /mtr				
				Nbr	D mm	E mm	Z2 (°)	Z1 (°)		1,2 mm	1,5 mm	2,0 mm	2,5 mm
SILO JET 14-100	141	105	121	2	9	70	0,90	0,54	7,15	0,36			
SILO JET 18-100	181	105	121	2	9	100	1,15	0,71	7,15	0,43			
SILO JET 23-135	231	139	155	2	9	120	2,65	1,65	6		0,93		
SILO JET 15-140	156	145	119	2	9	70	1,29	1,00	7,15		0,57		
SILO JET 18-140	186	145	119	2	9	100	1,55	1,20	7,15		0,69		
SILO JET 20-140	206	145	119	2	9	100	1,72	1,33	7,15		0,76		
SILO JET 23-140	236	145	119	2	9	120	1,98	1,53	7,15		0,88		
SILO JET 20-160	206	162	140	2	9	100	2,50	1,87	6			1,15	
SILO JET 22-160	226	162	140	2	9	100	2,75	2,06	6			1,27	
SILO JET 24-160	246	162	140	2	9	120	3,00	2,25	6			1,38	
SILO JET 26-160	266	162	140	3	9	80	3,25	2,43	6			1,50	
SILO JET 28-160	286	162	140	3	9	80	3,55	2,70	6			1,61	
SILO JET 30-185	306	185	165	3	9	100	4,58	3,80	5,50			2,47	
SILO JET 33-185	336	185	165	3	9	110	5,30	4,15	5,50			2,71	
* SILO JET 24-195	246	195	182	2	9	120	4,65	3,50	5			1,79	
* SILO JET 26-195	266	195	182	3	9	80	5,05	3,85	5			1,97	
* SILO JET 28-195	286	195	182	3	9	80	5,35	4,15	5			2,12	
* SILO JET 30-195	306	195	182	3	9	100	6,25	5,00	5				2,80
* SILO JET 33-195	336	195	182	3	9	100	6,80	5,50	5				3,10
SILO JET 30-225	310	230	200	3	9	100	7,95	6,50	4,50			2,60	3,20
SILO JET 37-225	380	230	200	4	9	90	9,75	7,80	4,50				3,90
SILO JET 38-225	390	230	200	4	9	90	10,00	8,00	4,50				4,00
SILO JET 40-225	410	230	200	4	11	100	10,75	8,75	4,50				4,20
SILO JET 42-225	430	230	200	5	11	80	11,30	9,20	4,50				4,30
SILO JET 43-225	440	230	200	5	11	90	11,55	9,40	4,50				4,40
SILO JET 48-225	490	230	200	5	11	90	12,90	10,50	4,50				5,00

Utiliser vis tête fraisée à ergots (voir page 17) / Use countersunk lug bolt (see page 17)

* Mécano-soudé / Welded steel

Document non contractuel - Non contractual document



Columbus DIN 15232

ACIER EMBOUTI
Céréales - Produits légers - Pellets
PRESSED STEEL
Cereals - Light materials - Pellets

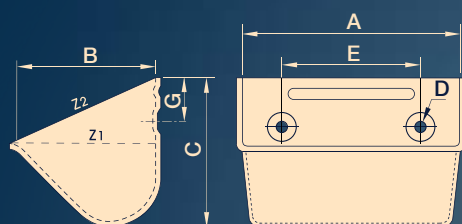

N°	A mm	B mm	C mm	Trous/Holes			Capacité/Capacity		Godets/Buckets /mtr	Poids/Weight Kg			
				Nbr	D mm	E mm	Z ₂ (e)	Z ₁ (e)		1,0 mm	1,5 mm	2,0 mm	3,0 mm
COL 07-070	70	70	70	2	8	34	0,18	0,12	11,50	0,095			
COL 08-075	80	75	80	2	8	43	0,25	0,16	10	0,125			
COL 09-080	90	80	85	2	8	46	0,34	0,22	9	0,155			
COL 10-090	100	90	91	2	8	58	0,41	0,27	8,50	0,180			
COL 11-095	110	95	95	2	8	64	0,48	0,32	8	0,210			
COL 12-100	120	100	105	2	8	67	0,63	0,42	8	0,250			
COL 13-105	130	105	110	2	8	78	0,75	0,50	7	0,300			
COL 14-115	140	115	117	2	8	86	0,96	0,63	6,50	0,330			
COL 15-125	150	125	123	2	8	87	1,18	0,77	6	0,360			
COL 16-125	160	125	126	2	8	101	1,20	0,89	5,50		0,570		
COL 18-130	180	130	130	2	9	110	1,55	1,05	5,50		0,670		
COL 20-140	200	140	145	2	9	131	2,15	1,45	5		0,840		
COL 22-145	225	145	153	3	9	70	2,50	1,83	5		1,010	1,34	
COL 25-150	250	150	158	3	9	77	3,10	2,11	5		1,120	1,48	
COL 30-155	300	155	160	3	9	104	4,50	2,84	4,50		1,350	1,80	
COL 35-180	350	180	190	4	10	90	6,50	4,03	4		2,000	2,66	
COL 40-200	400	200	212	4	11	100	8,70	5,60	3			3,35	
COL 50-225	500	224	236	5	14	100	13,50	9,00	3				5,84

Utiliser vis tête fraisée à ergots (voir page 17) / Use countersunk lug bolt (see page 17)

MATIÈRE PLASTIQUE INJECTÉE HDPE/PA6
Céréales - Produits légers - Pellets
PLASTIC MATERIAL INJECTED HDPE/PA6
Cereals - Light materials - Pellets

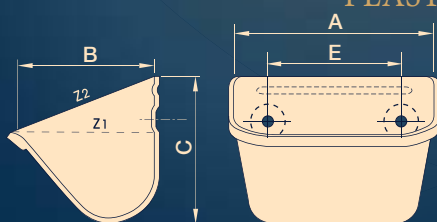

N°	A mm	B mm	C mm	Trous/Holes			Capacité/Capacity		Godets/Buckets /mtr	Poids/Weight Kg	
				Nbr	D mm	E mm	Z ₂ (e)	Z ₁ (e)		HDPE	PA 6
COL 08-080	80	80	78	2	8	45	0,23	0,11	10	0,035	0,045
COL 10-090	100	95	93	2	8	48	0,38	0,25	8,50	0,050	0,060
COL 12-105	120	105	105	2	8	63	0,58	0,45	8	0,072	0,090
COL 14-115	140	115	110	2	8	80	0,85	0,60	6,50	0,095	0,120
COL 16-130	160	130	120	2	8	96	1,20	0,90	5,50	0,130	0,185
COL 18-130	180	130	135	2	8	103	1,60	1,10	5,50	0,160	0,205
COL 20-140	200	140	150	2	10	118	2,00	1,35	5	0,230	0,290
COL 25-170	250	170	165	3	10	77	2,80	2,00	5	0,360	0,480
COL 32-185	315	185	170	3	11	109	4,60	3,00	4,50	0,620	0,810

Utiliser vis tête fraisée à ergots (voir page 17) / Use countersunk lug bolt (see page 17)

MATIÈRE PLASTIQUE INJECTÉE HDPE/PA6/PU/HDPE Z20

Céréales - Produits légers - Produits fragiles

PLASTIC MATERIAL INJECTED HDPE/PA6/PU/HDPE Z20

Cereals - Light materials - Fragiles materials

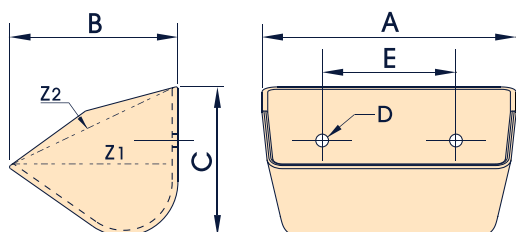

N°	A mm	B mm	C mm	Trous/Holes			Capacité / Capacity		Godets / Buckets /mtr	Poids/Weight Kg		
				Nbr	D mm	E mm	Z2 (c)	Z1 (c)		HDPE	PA 6	PU
SPB 15-125	155	125	120	2	8,5	70	1,00	0,58	7	0,24	0,27	0,29
SPB 18-125	180	125	120	2	8,5	100	1,25	0,70	7	0,29	0,33	0,35
SPB 20-135	200	135	130	2	8,5	100	1,69	1,04	6	0,32	0,36	0,38
SPB 22-160	220	160	160	2	8,5	100	2,65	1,70	5,25	0,50	0,57	0,60
SPB 24-160	240	160	160	2	8,5	120	2,92	1,88	5,25	0,54	0,62	0,64
SPB 26-160	260	160	160	3	8,5	80	3,19	2,05	5,25	0,57	0,65	0,68
SPB 28-160	280	160	160	3	8,5	80	3,46	2,20	5,25	0,60	0,68	0,71
SPB 30-190	300	190	190	3	8,5	100	5,15	3,34	4,50	0,95	1,08	1,13
SPB 35-190	350	190	190	3	8,5	135	6,08	3,95	4,50	1,10	1,25	1,31
SPB 40-210	400	210	210	3	8,5	135	9,13	6,16	4	1,32	1,50	1,57

Utiliser vis tête fraisée à ergots (voir page 17)/Use countersunk lug bolt (see page 17)

BOLJET®

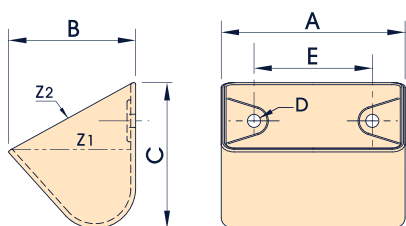

N°	A mm	B mm	C mm	Trous/Holes			Capacité / Capacity		Godets / Buckets /mtr	Poids/Weight Kg		
				Nbr	D mm	E mm	Z2 (c)	Z1 (c)		HDPE	PA 6	PU
B 10-080	100	81	95	2	8,5	50	0,25	0,15	8	0,05	0,06	0,06
B 12-090	120	90	105	2	8,5	50	0,35	0,20	7,50	0,07	0,08	0,09

Utiliser vis tête fraisée à ergots (voir page 17)/Use countersunk lug bolt (see page 17)



ACIER SOUDÉ Industrie lourde WELDED STEEL Heavy industry

DIN 15232

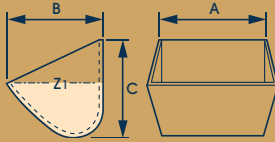

N°	A mm	B mm	C mm	Z1 (°)	Godets/Buckets /mtr
NJS 160-125	160	125	132	0,90	7,00
NJS 200-140	200	140	150	1,40	6,00
NJS 250-160	250	160	170	2,24	5,50
NJS 315-180	315	180	190	3,55	5,00
NJS 400-200	400	200	212	5,50	4,50
NJS 500-224	500	224	236	9,00	4,00
NJS 630-250	630	250	265	14,00	3,50
NJS 800-280	800	280	300	23,30	3,00

DIN 15234

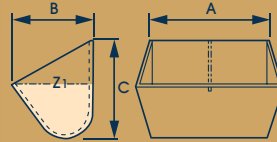

N°	A mm	B mm	C mm	Z1 (°)	Godets/Buckets /mtr
NJS 160-160	160	160	200	1,90	4,50
NJS 200-160	200	160	200	2,40	4,50
NJS 250-200	250	200	250	4,60	3,50
NJS 315-200	315	200	250	5,80	3,50
NJS 400-224	400	224	280	9,40	3,00
NJS 500-250	500	250	315	14,90	3,00
NJS 630-280	630	280	355	23,50	2,50
NJS 800-315	800	315	400	37,30	2,00
NJS 1000-355	1000	355	450	58,30	2,00

DIN 15233

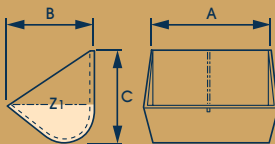

N°	A mm	B mm	C mm	Z1 (°)	Godets/Buckets /mtr
NJS 160-160	160	160	180	1,20	5,00
NJS 200-160	200	160	180	1,50	5,00
NJS 250-200	250	200	224	3,00	4,00
NJS 315-200	315	200	224	3,80	4,00
NJS 400-224	400	224	250	5,90	3,50
NJS 500-250	500	250	280	9,30	3,00
NJS 630-280	630	280	315	14,60	3,00
NJS 800-315	800	315	355	23,30	2,50
NJS 1000-355	1000	355	400	37,60	2,00

DIN 15235

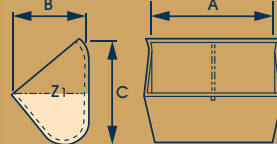

N°	A mm	B mm	C mm	Z1 (°)	Godets/Buckets /mtr
NJS 160-160	160	160	224	1,90	4,00
NJS 200-160	200	160	224	2,40	4,00
NJS 250-200	250	200	280	4,60	3,00
NJS 315-200	315	200	280	5,80	3,00
NJS 400-224	400	224	315	9,40	3,00
NJS 500-250	500	250	355	14,90	2,50
NJS 630-280	630	280	400	23,50	2,00
NJS 800-315	800	315	450	37,30	2,00
NJS 1000-355	1000	355	500	58,30	1,50

OPTIONS POSSIBLES TOUS GODETS MÉTAL POSSIBLE OPTIONS ALL STEEL BUCKETS

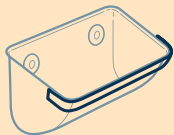

Plat de renfort avant soudé
Welded front reinforcement

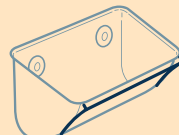

Moulure de renfort avant
Front reinforcement moulding

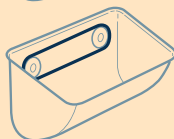

Plat de renfort arrière boulonné
Bolted rear reinforcement



Moulure de renfort arrière
Rear reinforcement moulding

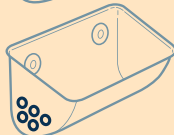

Perçages latéraux
Lateral borings



Perçages au fond
Bottom borings

GODETS SPÉCIAUX SPECIAL BUCKETS

Etudes technique et devis sur demande - Technical research and quotation on request

BOULONNERIE BOLTS

Pour godet à trous emboutis / For bucket with recessed holes

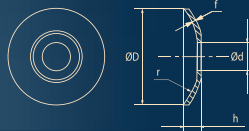
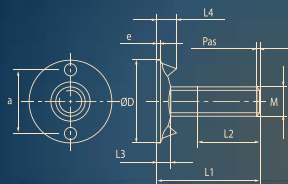

Vis à tête fraisée à ergots / Countersunk lug bolt	Codification	M	L1	ØD	L2	Pas	L3	L4	a	eMax
	04VEZS07025	7	25	20	18	1,00	3,5	5	14	1
	04VEZS07028	7	28	24	18	1,00	4,0	6	16	1
	04VEZS08030	8	30	25	20	1,25	4,5	6	18	1
	04VEZS08035	8	35	28	18	1,25	4,5	6	20	1
	04VEZS10040	10	40	35	30	1,50	5,5	7	25	1,5
	04VEZX10036	10	36	35	20	1,50	7,0	7	22	2,0

Codification	M	ØD	Ød	h	r	f
50ZREZ0724	7	24	8,2	3,4	22,8	1,2
50ZREZ0829	8	29	8,5	5,2	22,8	1,2
50ZREZ1038	10	38	11	5,3	45,5	2,0
50ZREZ1240	12	40	13	8,3	30	2,0

Codification	Ecrous/Nuts Zinc*	Codification	Ecrous freins/ Self locking nuts Zinc*
04EHZ08	M8	04EFZ08	M8
04EHZ10	M10	04EFZ10	M10
04EHZ12	M12	04EFZ12	M12

* Disponible en inox / Available in stainless steel

Pour godet à trous non emboutis / For bucket with no recessed holes

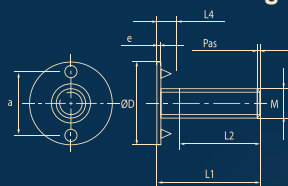

Vis à tête plate à ergots / Flat lug bolt	Codification	M	L1	ØD	L2	Pas	L4	a	e
	04VEZP06030	6	30	20	25	1,00	3,7	15	1,5
	04VEZP08030	8	30	30	23	1,25	4	22	1,5
	04VEZP10040	10	40	35	32	1,50	5	25	2

Pour godet plastique / For plastic bucket						
	Codification	M	ØD	Ød	f	
	Zinc*					
	04RPZ0624	6	24	6,3	1,2	
	04RPZ0830	8	30	8,3	1,5	
	04RPZ1036	10	36	10,5	2,0	

Pour godet métal / For steel bucket						
	Codification	M	ØD	Ød	f	
	Zinc*					
	04RPZ0614	6	14	6,3	1	
	04RPZ0818	8	18	8,3	1,5	
	04RPZ1022	10	22	10,5	2,0	

Codification	Ecrous/Nuts Zinc*	Codification	Ecrous freins/ Self locking nuts Zinc*
04EHZ07	M7	04EFZ07	M7
04EHZ08	M8	04EFZ08	M8
04EHZ10	M10	04EFZ10	M10
04EHZ12	M12	04EFZ12	M12

* Disponible en inox / Available in stainless steel

JONCTIONS DE SANGLE BELT JUNCTION

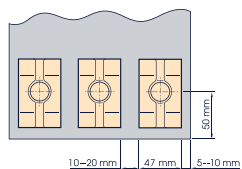

Forgées - Drop forged steel

MAXIGRIP 1 - ≤ 630 N/mm

MAXIGRIP 2 - 800 N/mm à 1 600 N/mm

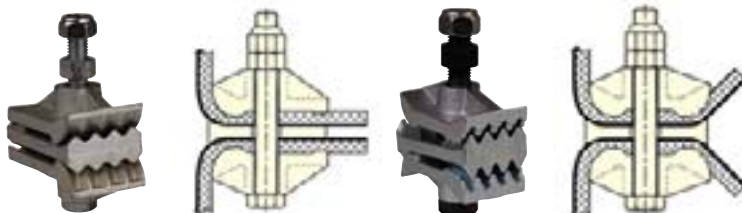

MÉCANO SOUDÉES WELDED STEEL



S	D	DR
100 N/mm à 315 N/mm	400 N/mm à 630 N/mm	800 N/mm à 1000 N/mm
L	50 - 98 - 128 - 148	

COMMENT MESURER UN GODET ? HOW TO MEASURE A BUCKET ?

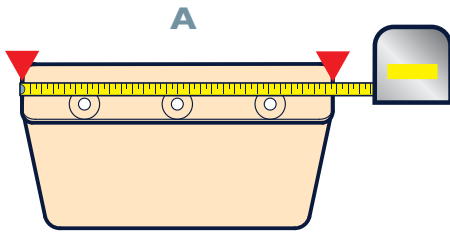

A

Largeur du godet:
Mesure extérieure

Width of the bucket:
External measurement

A

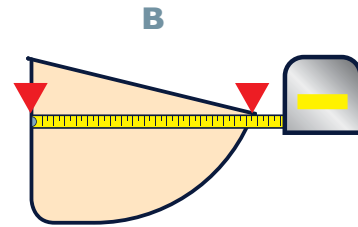

B

Profil du godet:
Godet posé le dos contre un mur
Mesure horizontale du dos au bec

Profile of the bucket:
Bucket lying on its back against a wall
Measurement horizontal from the back to the edge

B

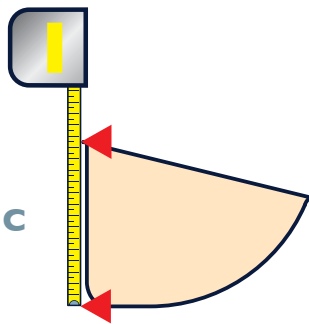

C

Hauteur du godet:
Mesure de la hauteur hors tout

Height of the bucket:
Measurement of the total height

C

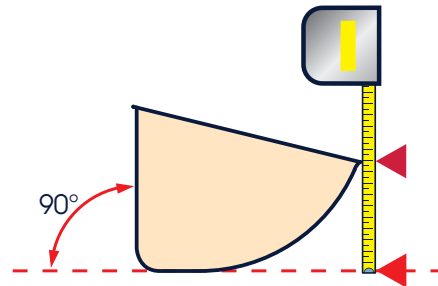

90°

Hauteur au bec:
Godet posé le dos contre un mur
Mesure de la hauteur au bec

Height at the edge:
Bucket lying on its back against a wall
Measurement from the height to the edge

Epaisseur:
Mesure au pied à coulisse de l'épaisseur

Thickness:
Measurement of the thickness with a caliper rule

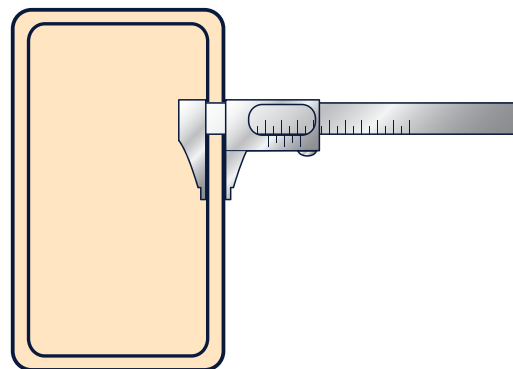



STIF C'EST AUSSI...

STIF IT'S ALSO...

BELTJET® SANGLE ÉLÉVATRICE ELEVATOR BELT



- Stock important
- Large gamme
- Coupe et perçage

- Délai rapide
- Support technique

- Lot of products in stock
- Wide range
- Our belts can be cut and punched

- Short delivery time
- Technical back up

SENSORJET®

VIGIBELT® CDS 80 C

Contrôleur de départ de sangle étanche
Dustproof belt alignment system

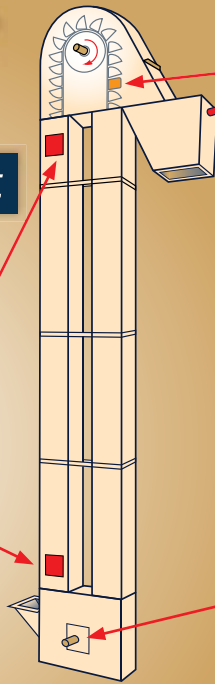
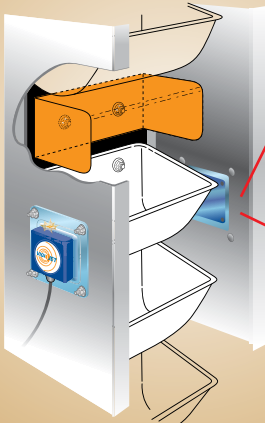

VIGITHERM® GST 100

Sonde température
Bearing temperature sensor

VIGIMAT® DNC 30

Sonde anti-bourrage
Level & chock sensor

VIGITHERM® GST 100

Sonde température
Bearing temperature sensor

VIGIRO® SV 26

Contrôleur de rotation directeur de sous-vitesse étanche
Dustproof under speed monitor

VIGILEX® WWW.VIGILEX.EU



ÉVÉNEMENTS D'EXPLOSION EXPLOSION VENT PANELS

Système de protection pour silos, trémies, broyeurs, ou systèmes d'extraction
Système breveté - Calcul de surface d'évent - Pas de contre-bride au montage
Inox 304L ou 316L

Protection system for silos, hoppers, grinders, or extraction systems
Patented system - Design facilities available - No addition flanges
Required to install - 304L or 316L Stainless Steel





www.stifnet.com

EUROPE

STIF

(Siège Social / Head Office)

Usine / Factory

Z.A. de la Lande
49170 Saint-Georges-sur-Loire
FRANCE

Tél.: +33 2 41 72 16 82

Fax: +33 2 41 39 32 12

E mail: sales@stifnet.com

Web: www.stifnet.com

STIF IBERICA

Bureau Commercial

Sales Office

La Selva - 21 Nave 2

Pol. Indus. Les Salines

08880 Cubelles

BARCELONA - ESPAÑA

Tfno.: +34 938 950 262

Fax: +34 938 950 298

E mail: ventas@stifiberica.es

Web: www.stifnet.com

AMERICA

STIF AMERICA

Bureau Commercial

Sales Office

Edificio La Balinera, Vista Hermosa

Apdo. 0816-02943

PANAMÀ

Telf (1): (507) 261-5215

Telf (2): (507) 261-5223

Email: stifamerica@stifnet.com

ASIA

STIF (SUZHOU)

Usine / Factory

Unit 7, N° 2318

East Taihu Lake Road

Wuzhong District, Suzhou City

Jiangsu Province, CHINA

Ph.: +86 512 6656 8968

Fax: +86 512 6656 9128

E mail: sales@stif.cn

Web: www.stif.cn

STIF ASIA

Bureau Commercial

Sales Office

2 Jurong East St 21

#04-28K IMM Building

SINGAPORE 609601

Ph.: +65 6563-2098

Fax: +65 6562-6083

E mail: sales@stif.com.sg

Web: www.stifnet.com

PT. STIF INDONESIA

Bureau Commercial

Sales Office

Jl. Ratna no. 1A

BEKASI – 17412

INDONESIA

Ph.: +62 21 8499 6745

Fax: +62 21 8499 5151

Email: indo@stif.com.sg