

Sos. Colentina Nr.381, Bucuresti, Romania

+ 40 737 925 412 / + 40 31 424 19 10

contact@ravtools.ro

<https://www.facebook.com/ravtools/>

**RAV  
TOOLS**

S.C. RAV TOOLS S.R.L.  
CUI (VAT) RO 35365760  
Reg.Com. J40/15815/2015

www.ravtools.ro

# Astra 3 Axis

**Masina pentru prelucrarea  
pietrelor naturale si recompuse.**

Machine for processing  
natural stones and agglomerates



**EMMEDUE**  
MARBLE AND GRANITE MACHINERY

# Astra 3 Axis

**Masina automata de taiat in 3 axe**

*Automatic bridge saw machine with 3 axes*



**Banc de lucru rotativ**  
*Rotating worktable*



**Banc de lucru inclinabil hidraulic**  
*Hydraulic tilting worktable*

**Versatila, precisa, fiabila si usor de utilizat**  
*Versatile, precise, reliable and easy to use.*



**Rotatie cap de taiere 0° - 90° -180°**  
*Rotating head 0° - 90° -180°*



**Inclinare manuala a capului de taiere 0° a 90°**  
*Manual tilting head from 0° to 90°*

## ))) Tele **Service**

**Telesistenta prin conexiune Internet pentru rezolvarea anumitor anomalii.**

*Teleservice through internet connection for the resolution of any anomalies.*



**Laser**



**Telecomanda cu fir**  
*Hand remote control*

## Detalii / Details

Masina de taiat cu pod rulant. Structura si masa de lucru executate din otel galvanizat si sudate prin tehnologie laser ce garanteaza o rezistenta ridicata la apa.

Glixare pe axele X / Y / Z prin intermediul rulmentilor cu limitatoare protejati prin intermediul burdufurilor.

Motorul discului are o putere HP18 - 13.2 Kw., si turatie de 1400 rpm. Discul poate avea diametrul maxim de 500 mm si asigura o adancime maxima de 145 mm

Rotatie manuala a capului de taiere 0° - 90° - 180°, inclinare manuala a capului de taiere de la 0° la 90° cu volan.

Panou control cu touch screen 10".

Accesoriu optional "Masa de lucru inclinabila hidraulic" faciliteaza asezarea placilor, crescand randamentul de productie.

**Astra 3 este ideala pentru realizarea diverselor lucrari cum ar fi : blaturi bucatarie, blaturi baie, mese, trepte, pardoseli, monumente funerare etc.**

*Bridge saw machine structure and work table made of hot galvanized dipped electro-welded steel that guarantees high water resistance.*

*X / Y / Z movement axes on slideways with ball-bearing guide blocks protected by bellows.*

*The blade motor has Hp18 – kW 13.2 power, speed 1400 Rpm cutting thicknesses up to 145 mm. with max. disc Ø 500 mm.*

*Manual rotation head in three positions, 0° - 90° - 180°, manual tilting head from 0° to 90°.*

*Panel control touch screen 10" with easy to use interface.*

*The optional tilting work table with hydraulic pump, promotes slab loading, speeding up the production process.*

**Astra 3 is ideal for indoor and outdoor designs such as kitchen counters, bathroom counters, capitals, tables, stairs, floors and Funeral art.**

## Accesorii / Accessories

**Structura monobloc galvanizata**  
*Galvanized monoBlock structure*

**Banco fix cu blat din lemn**  
*Fixed table with wood*

**Laser**  
*Laser*

**Protectii laterale cu celule fotoelectrice**  
*Fixed side protection with photoelectric barriers*

**Software pentru taiere 45°**  
*Software for 45° cutting*

**Software pentru utilizare facila**  
*Software easy to use*

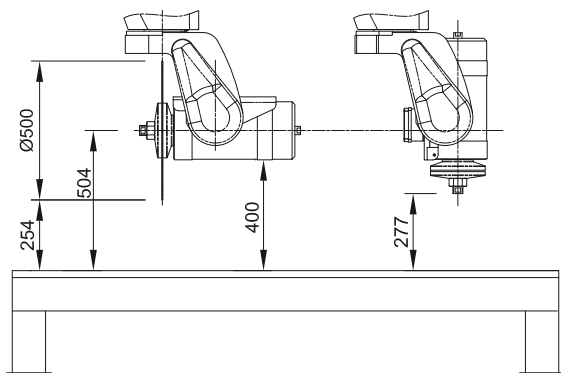

## Optionale

**Spalle in acciaio / Pereti beton armat**  
*Pereti laterali otel/ Concrete walls*

**Cap taiere pneumatic 0 - 90°**  
*Pneumatic head 0 - 90°*

**Plan de lucru inclinabil cu blat din lemn**  
*Tilting table with wood surface*

**Banc de lucru rotativ**  
*Index rotating work table*

**Superfata cauciucata pentru bancul de lucru**  
*Rubber surface for work table*

**Structura vopsita**  
*Painting structure*

**Telecomanda cu fir**  
*Hand remote control*

**Motor disc cu inverter Max. 3000 Rpm**  
*Blade motor with inverter Max. speed 3000 Rpm*

**Software pentru capiteluri drepte**  
*Software for straight capitals*

**Trasformator pentru tensiuni speciale**  
*Voltage transformer outside standard*

**Sistem manual de lubrifiere**  
*Manual lubrication system*

**Protectii posterioare**  
*Back protection*

**Teleasistenta**  
*Teleservice*

## Prelucrare / Processing

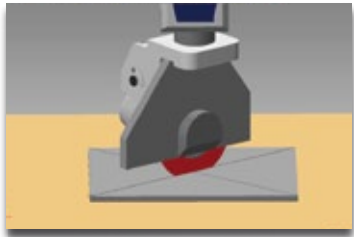

**Taiere diagonala**  
*Diagonal cuts*

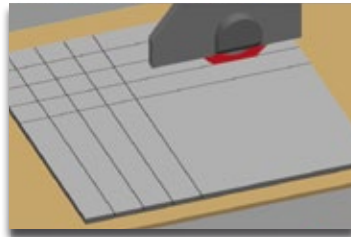

**Taieri multiple**  
*Multiple cuts*

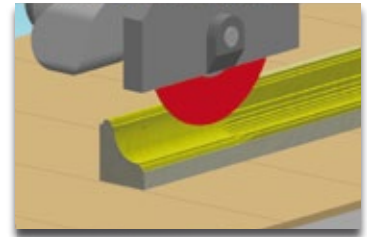

**Capiteluri drepte**  
*Straight capitals*

## Software 45°

**Program taiere 45°**  
*Program for 45° cutting*

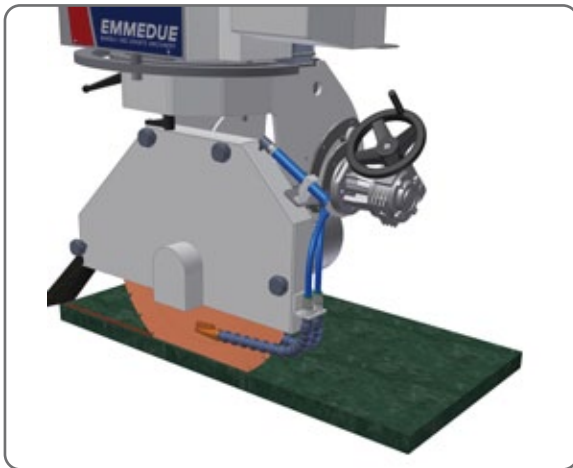

Astra 3 Axis		monobloc	pereti laterali
<b>Cursa longitudinala (axa X)</b> Max. stroke X axis	mm. Inch.	3500 137.80"	3500 137.80"
<b>Cursa transversala (axa Y)</b> Max. stroke Y axis	mm. Inch.	2000 78.74"	2000 78.74"
<b>Cursa verticala (axaZ)</b> Max. stroke Z axis	mm. Inch.	340 13.38"	340 13.38"
<b>Rotatie manuala cap taiere (axa C)</b> Manual rotating head C axis	°	0 - 90 - 180	0 - 90 - 180
<b>Inclinare manuala cap taiere (axa A)</b> Manual tilting head A axis	°	0 / 90	0 / 90
<b>Viteza max. axa X</b> Max. speed X axis	mt/min Inch./min	10 393"	10 393"
<b>Viteza max. axa Y</b> Max. speed Y axis	mt/min Inch./min	10 393"	10 393"
<b>Viteza max. axa Z</b> Max. speed Z axis	mt/min Inch./min	0.6 23"	0.6 23"
<b>Putere motor principal (S6)</b> Main motor power	kW/Hp	13.2 / 18	13.2 / 18
<b>Viteza rotatie disc</b> Speed main motor	Rpm	1400	1400
<b>Diametru Max - Min. disc / Ø inter.</b> Diameter blade Max - Min. / Ø hole	mm. Inch.	500 - 350/60 19.68" - 13.78"/2.36"	500 - 350/60 19.68" - 13.78"/2.36"
<b>Adancime max. de taiere</b> Maximum cutting depth	mm. Inch.	145 5,70"	145 5,70"
<b>Dimensiune banc de lucru</b> Table dimension	mm. Inch.	3400 x 1900 133.86" x 74.80"	3400 x 1900 133.86" x 74.80"
<b>Greutate aproximativa</b> Approximate Weight	kg lb	3000 6613	3000 6613
<b>Dimensiune masina</b> Dimensions	mm. Inch.	5450 x 4080 x 2710 215" x 161" x 107"	5450 x 4080 x 2710 215" x 161" x 107"
<b>Dimensiuni de ambalare</b> Packaging dimensions	mm. Inch.	5450 x 2300 x 2300 214" x 91" x 91"	5450 x 2300 x 2300 214" x 91" x 91"
<b>Tensiune standard</b> Standard voltage	Volt / Hz	400 / 50	400 / 50

I dati tecnici di cui sopra sono da considerarsi indicativi e soggetti a variazioni senza preavviso.  
The above technical data is for general information only and is subject to change without notice

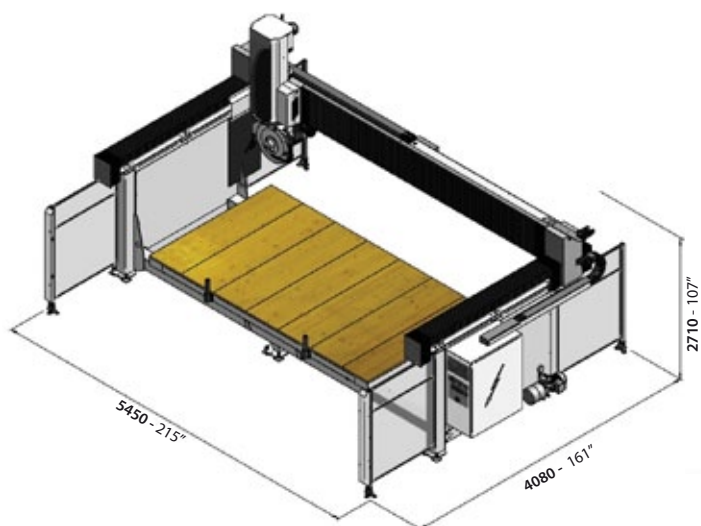

**Structura monobloc faciliteaza operatiunile de incarcare / descarcare transporto e posa in opera.**  
Easy to load, unload, transport and install thanks to its monoBlock structure.

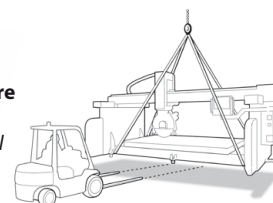



## Azienda / Company

Emmedue este unul din brand-urile producatorului de masini pentru piatra Industrie Montanari din 1990 . gama de produse include masini de taiat pentru santiere, masini de taiat automate si centre de prelucrare CNC pentru ateliere sau fabrici de mari dimensiuni.

De-a lungul anilor compania s-a dezvoltat in mod continuu, datorita eforturilor constante de cercetare pentru imbunatatirea caracteristicilor tehnice a masinilor, dar si datorita eforturilor noastre si a partenerilor in domeniul dezvoltarii serviciilor pre si post-vanzare.

Punctul forte al companiei a fost intotdeauna reprezentat de investitia in noi tehnologii si in dezvoltarea resurselor umane. Acest lucru a permis companiei sa fie prezenta pe piete in toata lumea, devenind un punct de reper in industrie.

*Emmedue is one of the brands by Industrie Montanari, manufacturer of stone-working machines since the beginning of the 1990s. Its range of produce includes Saw for building sector, CNC Bridge Saw and Work Centres for small, mid-sized, and large laboratories.*

*Over the years, the company has grown significantly thanks to the continuous research and development on the machines, constant, daily commercial efforts in symbiosis with our partners; and technical service focused and attentive to both pre- and after-sale.*

*Emmedue's strength has always been its investment in new technologies and human resources. This has led the company to be present in markets around the world, becoming a benchmark in the industry.*

Main Suppliers:



Sumitomo Drive Technologies

Life Is On



YASKAWA

TexComputer

Dealer

# RAV TOOLS

**Bucuresti - Romania**

Tel. 0040 314241910

Mob. 0040 737925412

e-mail : [contact@ravtools.ro](mailto:contact@ravtools.ro)

**[www.ravtools.ro](http://www.ravtools.ro)**



*Emmedue is a brand of:*

**Industrie Montanari S.r.l.**

Via Fondo Ausa, 23 • 47891 Dogana • Repubblica di San Marino

Tel. (+378) 0549 908926 • Fax (+378) 0549 908875

[emmedue@industriemontanari.sm](mailto:emmedue@industriemontanari.sm)

[www.emmedue.sm](http://www.emmedue.sm) • [www.industriemontanari.sm](http://www.industriemontanari.sm)



Member of:

