

HJB 120 T4 1,1kW

Series general data HJB



MANUFACTURING FEATURES:

- Completely made of galvanized steel sheet.
- Equipped with gravity shutter.
- Aluminium impeller.
- Protection grid on pulley area.
- Standard asynchronous squirrel-cage motor with IP-55 protection and class F insulation. Manufactured with standard voltage: 230/400V 50Hz.

APPLICATIONS:

- Designed for wall assembly, they are suitable for:
- Air renewal in buildings and industries.
 - Farms and greenhouses.
 - Maximum working temperature: 50°C.

Series accessories HJB



Characteristic curve

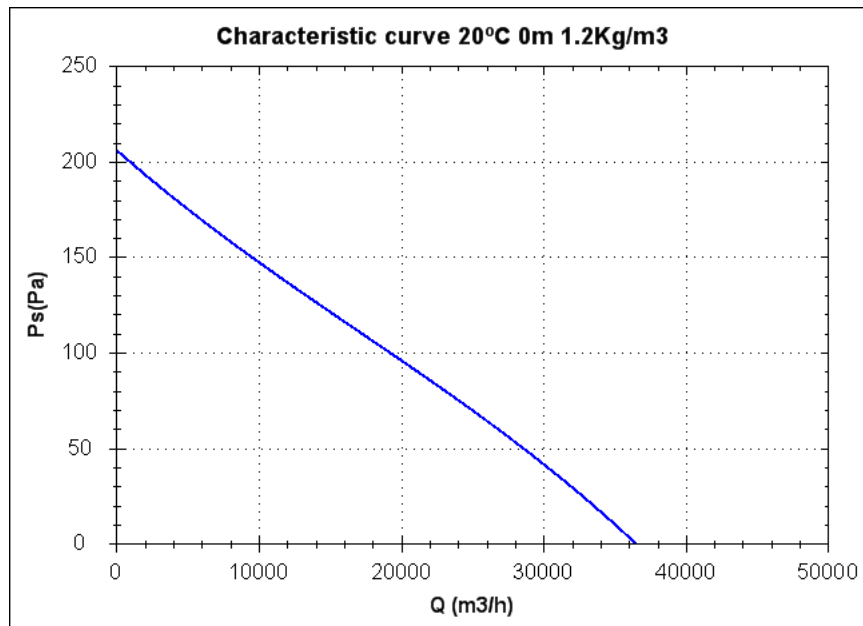

Design point

Q (m3/h)	
Ps(Pa)	

Service point

Impeller rpm	
Max. temp.(°C)	
Q (m3/h)	
Ps(Pa)	
Pd(Pa)	
Pt(Pa)	
Air speed(m/s)	

Technical data

Impeller rpm	450
Motor rpm	1450
Approx. weight(kg)	88
Maximum flow rate(m3/h)	37000

Power(kW)	1,1
Imax 230V(A)	4,8
Imax 400V(A)	2,8
Imax 690V(A)	-

HJB 120 T4 1,1kW

dimensions diagram

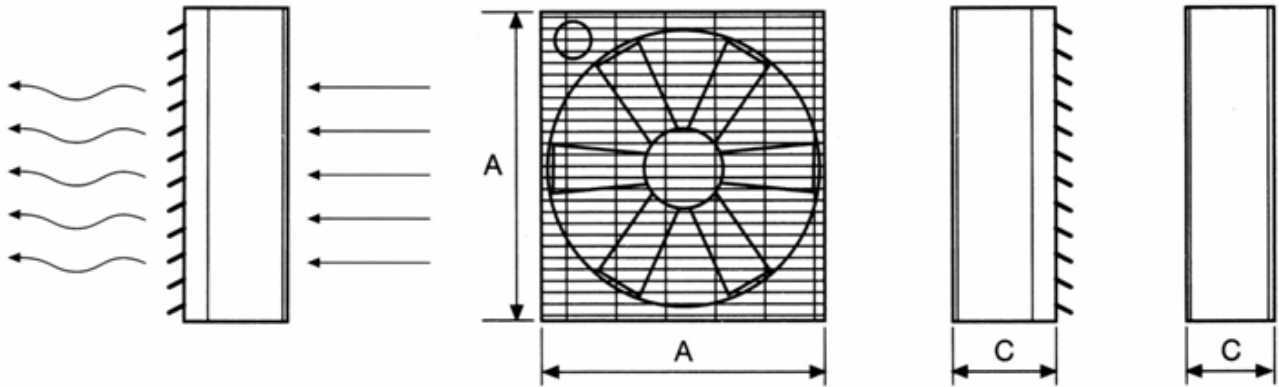

Dimensions (mm)

A=1380	C=400
--------	-------

Wiring diagram

