

Diamond grinding discs

Grinding discs 1A1

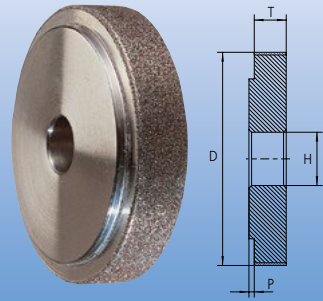

Diamond grinding discs are intended for use on stationary machines. Grinding discs with an outer diameter of more than 18 mm have an additional centring shoulder which allows them to be accurately mounted and aligned on the machine spindle. Combined with a stable mandrel, these tools are ideal for work in deep-set or long bores.

Please refer to page 8 for the recommended cutting speed.

Ordering example:
 EAN 4007220**665893**
 D1A1 12-10-8 D 151

Description	Grit size	EAN 4007220	Outer dia. x total width D x T [mm]	Centre hole dia. H [mm]	Width centring shoulder P [mm]	
D1A1 12-10-8	D 151	665893	12.0 x 10	8	-	1
D1A1 14-10-8	D 151	665961	14.0 x 10	8	-	1
D1A1 16-10-8	D 151	665978	16.0 x 10	8	-	1
D1A1 18-10-8	D 151	665992	18.0 x 10	8	2	1
D1A1 20-10-8	D 151	354629	20.0 x 10	8	2	1
D1A1 30-10-10	D 151	354636	30.0 x 10	10	2	1
D1A1 40-10-10	D 151	354643	40.0 x 10	10	2	1
D1A1 50-10-10	D 151	354131	50.0 x 10	10	2	1

