



<http://www.lojadosrecuperadoresdecaldor.com>

 **ECOFORREST**



ANTRACITA 

BEIGE 

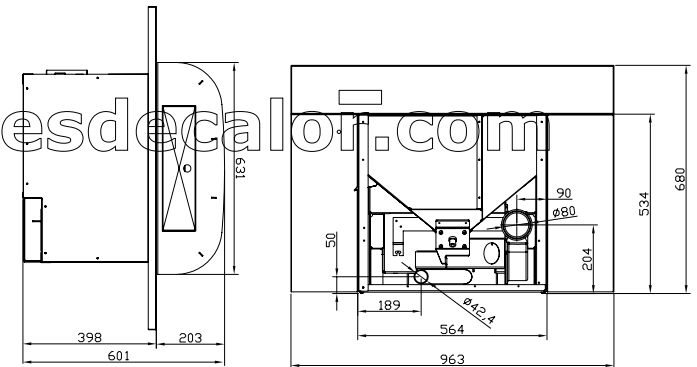

ECO II INSERT MINI AIRE

Potencia / Potenza / Potência / Puissance / Power: 9 kw
Rendimiento / Rendimento / Rendement / Effic iency: 90%
Tolva / Tramoggia / Tolva / Reservoir / Tank: 24 kg
Consumo / Consommation / Consumption: 600-2000 gr/h
Peso / Peso / Peso / Poids / Weight: 85 kg
Medidas / Misuri / Dimension / Measures: 631x601x550 mm