

Separator de hidrocarburi cu decantor namol si filtru coalescent tip SKH

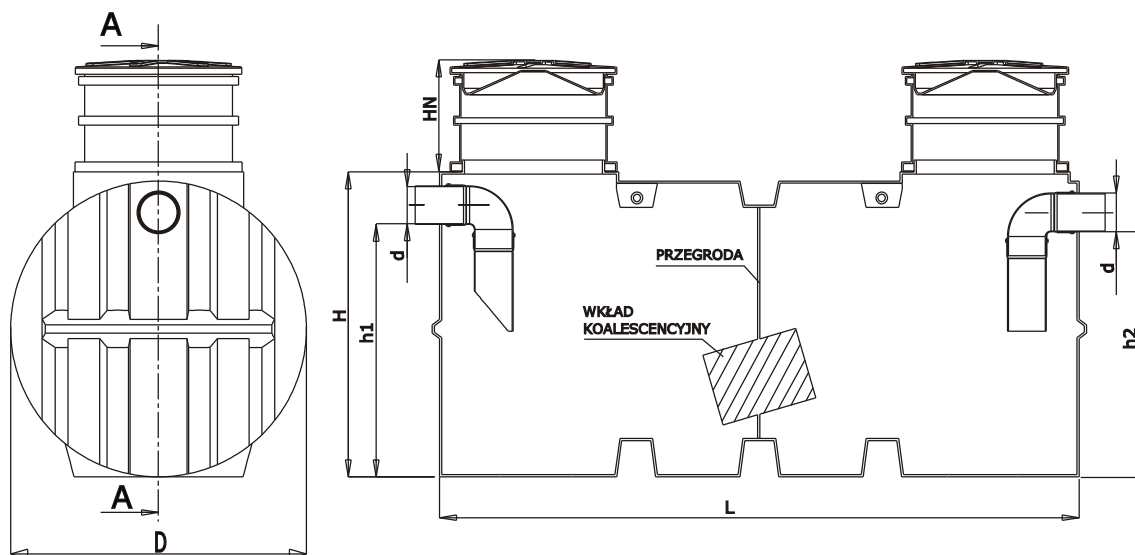

Parametrii separator:

Debit nominal:	2-8 l/s
Debit maxim:	2-8 l/s
Diam. guri de vizitare:	ø 600 ø 600
H gura de vizitare:	400 mm
Material:	HDPE $\rho=940 \text{ kg/m}^3$
Echipamente optionale:	- extensii; - capace carosabile; - sistem de alarma.

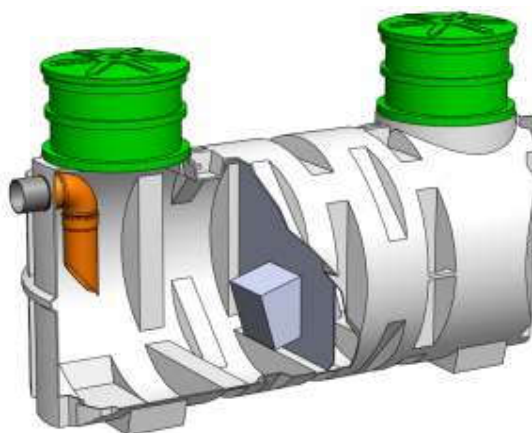

Tip separator	Debitul nominal [l/s]	Lungime L [m]	Diametru D [m]	Inaltime H [m]	Volum decantor [m ³]	Volum total [m ³]	Volum hidrocarburi [l]	d [mm]	h1/h2 [cm]
SKHD-2	2	1,7	1,2	1,2	0,7	1,7	250	110	107/103
SKH-3	3	1,7	1,2	1,2	0,6	1,7	290	160	102/98
SKHD-3	3	2,2	1,2	1,3	1,2	2,2	250	160	105/101
SKH-4	4	2,2	1,2	1,3	0,8	2,2	340	160	105/101
SKH-6	6	2,7	1,2	1,3	1,1	2,8	520	160	105/101
SKH-8	8-10	2,4	1,5	1,4	1,1	3,4	640	160	119/115
SKH-15	15	2,6	1,8	1,9	2	5,5	1200	200	150/147

In conformitate cu norma PN EN 858-2