

KESLA

TRACTOR FOREST EQUIPMENT



Superior forest machinery expertise

Kesla Oyj is a strong forest technology innovator with more than 50 years of experience in manufacturing high-quality Finnish forest machinery. The KESLA product family covers all work stages in timber harvesting and handling. In addition to timber harvesting and forestry, KESLA products are also used in energy production and the recycling industry along with ports and ships. KESLA products are exported to over 35 countries worldwide.

For over 30 years, Kesla has been a global pioneer in providing forest equipment for tractors. Kesla products sold under the PATU trademark have been the global market leader since the early 1980s. Kesla has developed a large selection of timber loaders, timber trailers and accessories that make it easy to equip a tractor for efficient timber harvesting. Kesla has great solutions for both heavy professional users and forest owners harvesting their own timber.

Kesla is the only manufacturer in the world that can bring its experience in heavy-duty timber truck cranes, forest machine cranes and industrial cranes to the world of tractor-mounted loaders and trailers. This experience shows in the superior features and durability of the products and in the manufacturer's ability to listen to and serve the customer over the product's entire service life.

KESLA products are a combination of cutting-edge technology and the highest quality of components and materials. During manufacture, each KESLA product passes through a rigorous international quality assurance programme as well as practical performance and safety tests. Product details are carefully considered and designed for the needs of customers, raising efficiency and reliability to a league of its own. The large product selection and comprehensive range of optional accessories, makes it possible to provide customers with customised solutions that are sure to meet their needs. Since durability and a long service life are focal points in Kesla's design work, customers are guaranteed uninterrupted working and superior resale value.



Kesla is a pioneer in tractor-mounted timber loaders and timber trailers and a global leader with over 30 years of experience.

Solid strength and reach

All KESLA loaders are designed for efficiency and usability as well as working safety. Each loader is a combination of solid strength, reach and agility. In practice, this is demonstrated in the precision, comfort and power of the work: the loader responds to the controls almost like it is reading the driver's mind. Many of the structural solutions used in the loaders are based on heavy-duty professional cranes used in trucks and forest machines, which makes KESLA an extraordinarily durable and reliable partner for forest work.



THE WIDEST RANGE OF LOADERS

KESLA's loader range has a solution for every purpose and for all conditions. The carefully designed standard equipment can be further enhanced with the widest range of accessories on the market.

SUPERIOR CONTROLLABILITY

The usability of loaders is the key to efficiency. The controllability of KESLA loaders can be further enhanced with a large selection of control valves ranging from mechanical to hydraulic electro-hydraulic control systems equipped with driver-specific adjustment options.

CAREFULLY CONSIDERED SOLUTIONS

Kesla's strong expertise is based on decades of experience all around the world with both tractor equipment and heavy-duty truck cranes and forest machine cranes. One example of solid structural solutions is the cast, oil-bath slew mechanism used in all models that forms the foundation for the loaders' long service life.

PROFESSIONAL GRAPPLES

Kesla's new ProG grapple line now covers the entire KESLA loader range from the smallest tractor-mounted loader to the most powerful truck crane models. Only KESLA can also bring true professional expertise to the tractor loader size class.

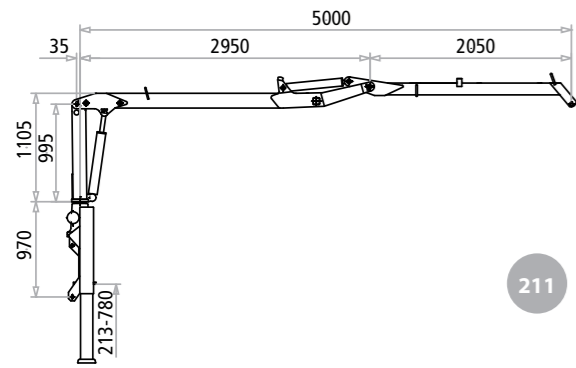

211

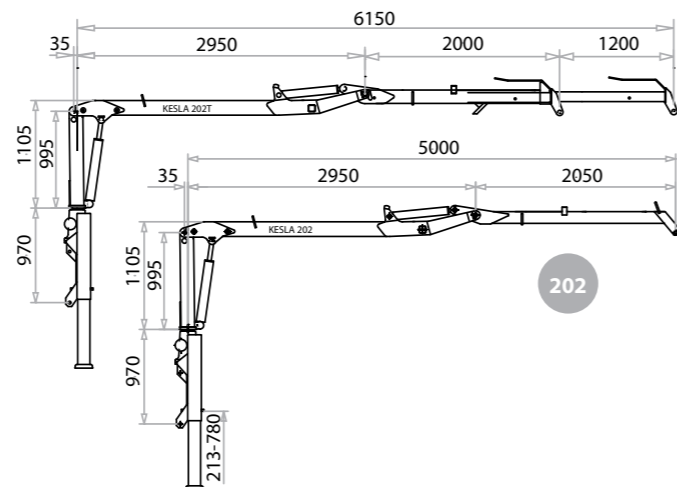

202

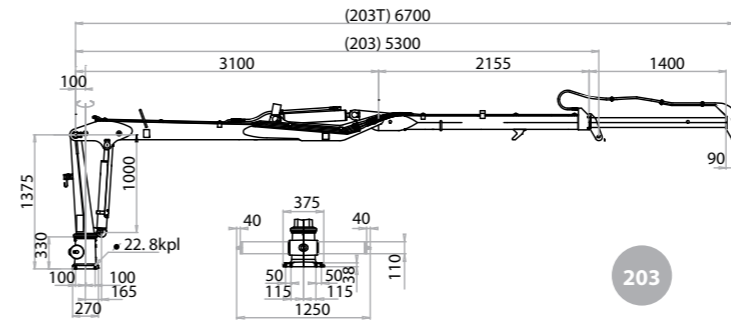

203

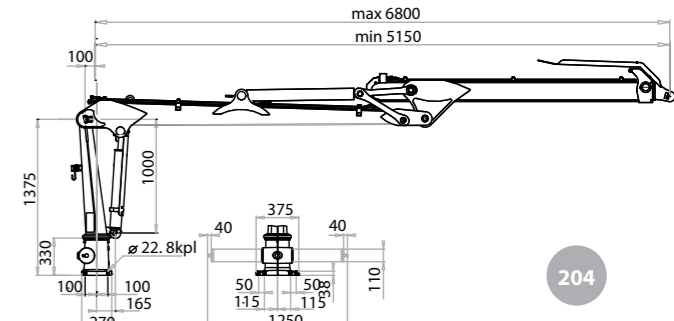

204

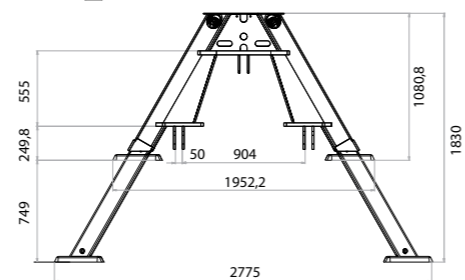

A-telesopic

The 200 Series for reliable timber harvesting

The KESLA 200 Series offers a wide and practical range of loaders equipped with advanced features that take the needs of users into account. The models in the series are sturdy and reliable loaders that enable ergonomic and smooth productiveness.

The loaders can be fitted with hydraulic stabiliser legs. The installation can be made to tractors' rear platform, above the trailer or with 3-point attachment. KESLA 200 Series loaders can be fitted with a wide range of accessories, such as hydraulic or electric pilot control, a radio-controlled winch and excavation accessories.



TECHNICAL SPECIFICATIONS	211	202	202T	203	203T	204T
Outreach	5,00 m	5,00 m	6,15 m	5,30 m	6,70 m	6,80 m
Boom extension	-	-	1,20 m	-	1,40 m	1,65 m
Lifting torque (net, 4 m)	19,8 kNm	19,8 kNm	16,7 kNm	30,5 kNm	27,0 kNm	31 kNm
Lifting torque (max, 4 m)	24,6 kNm	24,6 kNm	24,6 kNm	36,5 kNm	36,5 kNm	42 kNm
Lifting capacity at 3 m *	690 kg	690 kg	605 kg	890 kg	805 kg	900 kg
Lifting capacity at 4 m *	525 kg	525 kg	425 kg	780 kg	690 kg	795 kg
Lifting capacity at max. outreach *	415 kg	415 kg	275 kg	600 kg	405 kg	410 kg
Slewing angle	400 °	420 °	420 °	380 °	380 °	380 °
Slewing torque	4,9 kNm	7,1 kNm	7,1 kNm	8,0 kNm	8,0 kNm	8,0 kNm
Grapple	ProG 20	ProG 20	ProG 20	ProG 20	ProG 20	ProG 20
-area	0,18 m ²	0,18 m ²	0,18 m ²	0,18 m ²	0,18 m ²	0,18 m ²
-max. opening	124 cm	124 cm	124 cm	124 cm	124 cm	124 cm
Rotator	FR7 / 750 Nm	FR7 / 750 Nm	FR7 / 750 Nm	FR7 / 750 Nm	FR7 / 750 Nm	FR7 / 750 Nm
Working pressure	175 bar	175 bar	175 bar	175 bar	175 bar	190 bar
Recommended oil flow **	25-40 l/min	25-40 l/min	30-50 l/min	30-50 l/min	30-50 l/min	30-60 l/min
Weight ***	810 kg	835 kg	900 kg	950 kg	1 030 kg	1 095 kg
Trailer recommendation	Kesla 82	KESLA 92/92L/92HD/92LHD/10T/102H/102HD/102ND				

* Lifting capacity without grapple or rotator. The loader's lifting capacity depends on the boom's elevation and reach.

** Recommended oil flow depends on valve choice.

*** The weight of machines in the 200 series includes the grapple, rotator, link, mechanical valve and A-frame.

The 300 Series is the professional's choice

The design of the heavy-duty 300 Series has taken the efficiency and reach requirements of professional timber harvesting into account. The loaders are equipped with a wide-angle joint that improves loading in the immediate vicinity of the trailer and maintains the power of the transfer boom evenly over its entire working range. All 300 Series loaders come with a durable, cast and oil-bath 4-cylinder slew mechanism that gives plenty of slewing power.

KESLA 300 Series loaders can be installed on the tractor's rear axle or on the trailer. The loaders come with extensive standard features and can be fitted with a wide range of accessories, such as hydraulic or electric pilot control, working lights, special colours and several options for stabiliser legs and grapples.

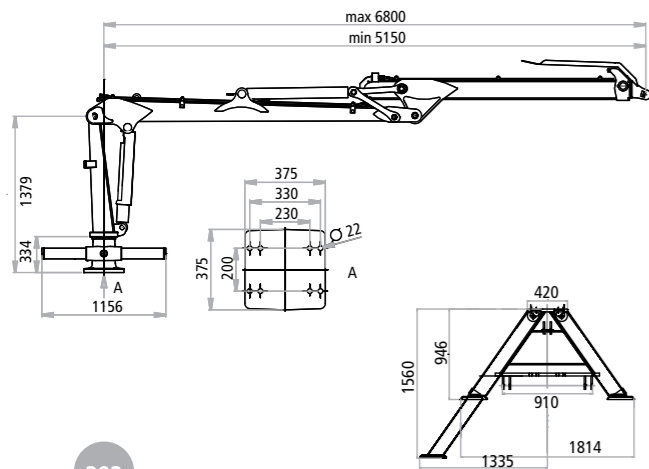

303

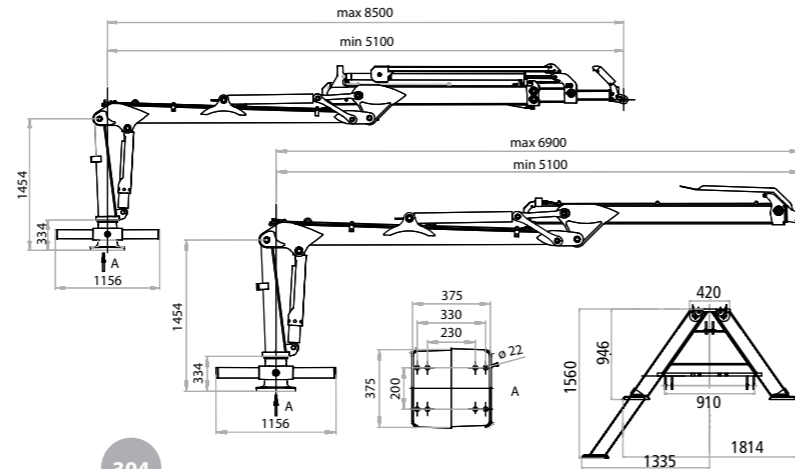

304

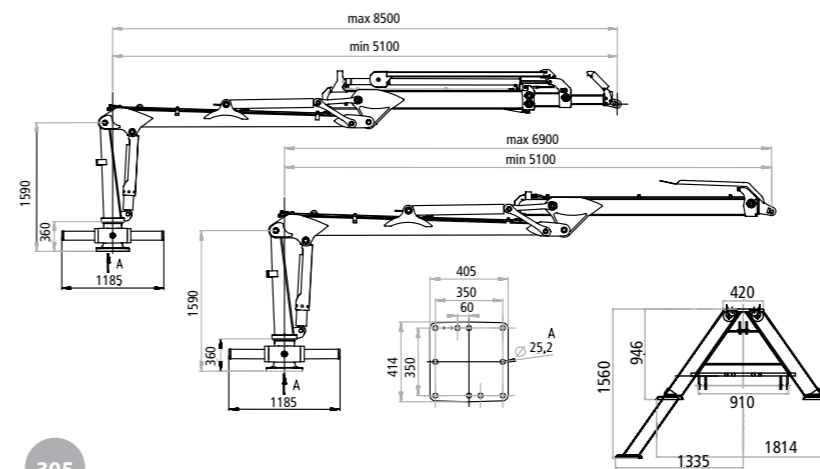

305



TECHNICAL SPECIFICATIONS	303	304	304T	305	305T	316	316T
Outreach	6,80 m	6,90 m	8,50 m	6,90 m	8,50 m	7,20 m	8,80 m
Boom extension	1,65 m	1,80 m	2 x 1,70 m	1,80 m	2 x 1,70 m	1,8 m	2x1,7 m
Lifting torque (net, 4 m)	31 kNm	43 kNm	39 kNm	52 kNm	45 kNm	60 kNm	52 kNm
Lifting torque (max, 4 m)	42 kNm	56 kNm	56 kNm	65 kNm	65 kNm	80 kNm	80 kNm
Lifting capacity at 3 m *	900 kg	1 430 kg	1 300 kg	1 650 kg	1 500 kg	2 150 kg	1 950 kg
Lifting capacity at 4 m *	795 kg	1 100 kg	1 000 kg	1 290 kg	1 150 kg	1 540 kg	1 370 kg
Lifting capacity at max. outreach *	410 kg	620 kg	430 kg	720 kg	490 kg	830 kg	560 kg
Slewing angle	380°	380°	380°	380°	380°	380°	380°
Slewing torque	13,5 kNm	13,5 kNm	13,5 kNm	16 kNm	16 kNm	19,5 kNm	19,5 kNm
Grapple	ProG 20	ProG 25	ProG 25	ProG 25	ProG 25	ProG 25	ProG 25
-area	0,18 m ²	0,24 m ²	0,24 m ²	0,24 m ²	0,24 m ²	0,24 m ²	0,24 m ²
-max. opening	124 cm	132 cm	132 cm	132 cm	132 cm	132 cm	132 cm
Rotator	FR7 / 820 Nm	FR10 / 900 Nm	FR10 / 900 Nm	FR15 / 1 100 Nm	FR15 / 1 100 Nm	CR 600FW/ 1500 Nm	CR 600FW/ 1500 Nm
Working pressure	190 bar	190 bar	190 bar	190 bar	190 bar	210 bar	210 bar
Recommended oil flow ** constant volume	30-50 l/min	40-70 l/min	40-70 l/min	50-80 l/min	50-80 l/min	50-80 l/min	50-80 l/min
Load-sensing system	100-120 l/min	100-130 l/min	100-130 l/min	110-140 l/min	110-140 l/min	110-140 l/min	110-140 l/min
Weight ***	885 kg	975 kg	1 070 kg	1 260 kg	1 370 kg	1 445 kg	1 570 kg
Trailer recommendation	KESLA 10T / 102H / 102HD / 102ND / 12T / 12H / 12HD / 12ND / 12MD/MDH						

** Lifting capacity without grapple or rotator. The loader's lifting capacity depends on the boom's elevation and reach.
** Recommended oil flow depends on valve choice.
*** The weight of machines in the 300 series includes the grapple, rotator, link and mechanical valve (without A-frame).

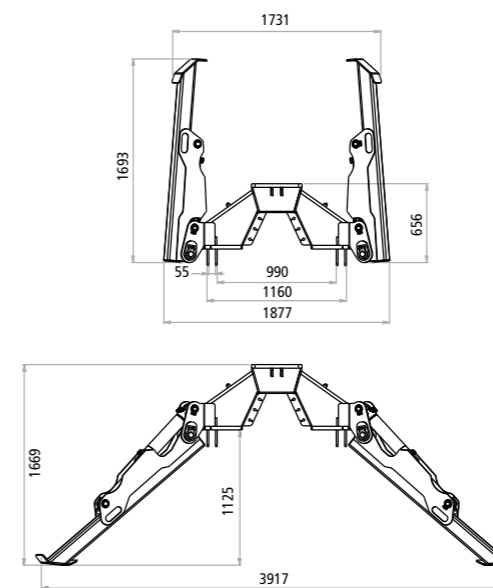

Flap-down stabiliser legs



Loaders for demanding conditions

Kesla's powerful forest machine cranes are suited to diverse professional use. These cranes can be used anywhere in the world, even in the most demanding conditions and at the most challenging sites. Installation options include rear axle of heavy-duty tractors, chipper feeds, forest machines and fixed installations at industrial facilities. KESLA 500 and 500T models can be installed on the beam of Kesla's 12-tonne timber trailers.

KESLA 500Z is the smallest member of the Z crane family and ideal for tractor installation. The transport position of the Z model gives freedom for installation and its space requirements are minimal. 500Z can be installed on the beam of KESLA trailers starting from the 92, and its transport position makes it ideal for installation on the beam of various tipper trailers.

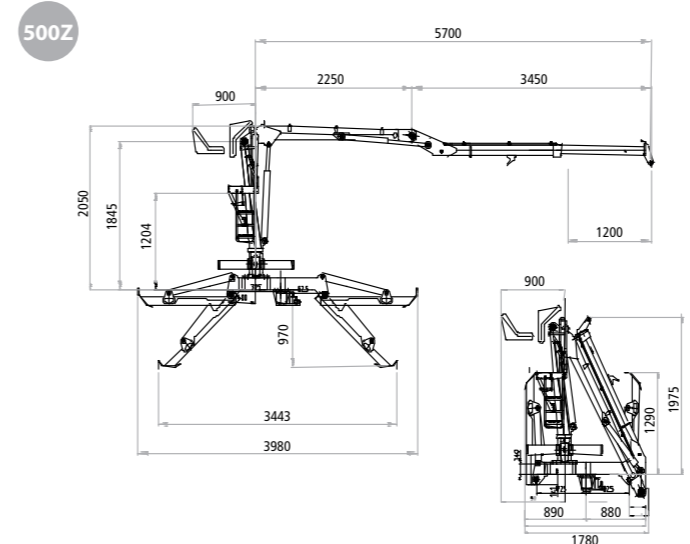
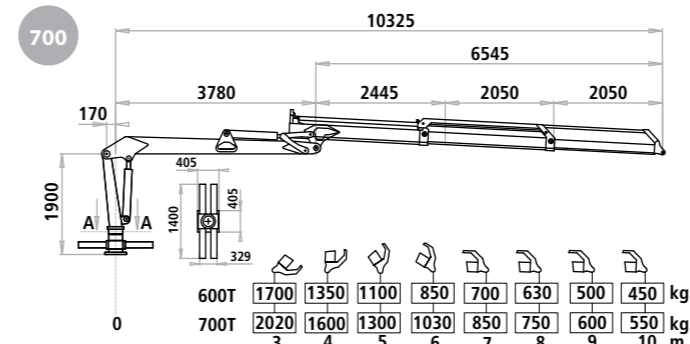
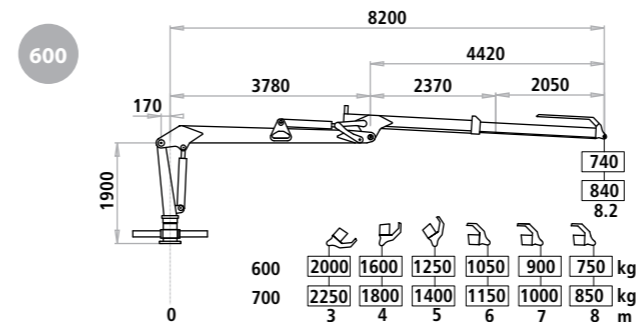
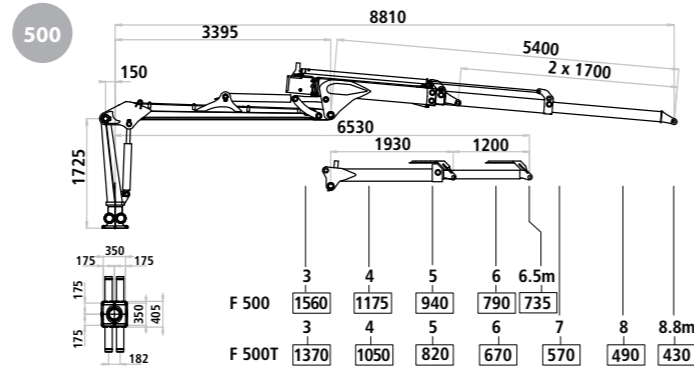

TECHNICAL SPECIFICATIONS	500	500T	600	600T	700	700T	500Z
Outreach	6,50 m	8,80 m	8,20 m	10,30 m	8,20 m	10,30 m	5,70 m
Boom extension	1,20 m	2 x 1,70 m	2,05 m	2 x 2,05 m	2,05 m	2 x 2,05 m	1,20 m
Lifting torque (net, 4 m)	47 kNm	41 kNm	60 kNm	53 kNm	70 kNm	64 kNm	27 kNm
Lifting torque (max, 4 m)	60 kNm	60 kNm	80 kNm	80 kNm	95 kNm	95 kNm	36 kNm
Lifting capacity at 4 m *	1 175 kg	1 050 kg	1 600 kg	1 350 kg	1 800 kg	1 600 kg	705 kg
Lifting capacity at max. outreach *	735 kg	430 kg	750 kg	450 kg	850 kg	550 kg	490 kg
Slewing angle	380 °	380 °	380 °	380 °	380 °	380 °	420 °
Slewing torque	16 kNm	16 kNm	24 kNm	24 kNm	24 kNm	24 kNm	7,1 kNm
Grapple	ProG 25	ProG 25	ProG 25	ProG 25	ProG 25	ProG 25	ProG 20
-area	0,24 m ²	0,24 m ²	0,24 m ²	0,24 m ²	0,24 m ²	0,24 m ²	0,18 m ²
-max. opening	132 cm	132 cm	132 cm	132 cm	132 cm	132 cm	124 cm
Working pressure	190	190	220	220	190	190	210
Recommended oil flow ** constant volume:	60-80 l/min	60-80 l/min	70-90 l/min	70-90 l/min	80-100 l/min	80-100 l/min	30-50 l/min
Load-sensing system	140-160 l/min	140-160 l/min	140-160 l/min	140-160 l/min	150-170 l/min	150-170 l/min	-
Weight ***	970 kg	1 150 kg	1 425 kg	1 610 kg	1 445 kg	1 630 kg	960 kg
Trailer recommendation	KESLA 12T / 12H / 12HD 12ND / 12MD/MDH		On the rear platform of heavy-duty tractors, forest tractors, fixed installations				KESLA 92/92L/9 2HD/92LHD/10 T/102H/102HD/ 102ND

* Lifting capacity without grapple or rotator. The loader's lifting capacity depends on the boom's elevation and reach.
** Recommended oil flow depends on valve choice.
*** Weight of booms of 500-800 Series machines

Kesla also offers a comprehensive range of products for fitting tractors for efficient chipping

KESLA C645 and C1060 are effective drum chippers for professional chipping. Due to their modular structure, they can be equipped with appropriate features to satisfy the user's requirements (depending on model): one- or two-axle base, drive, 16 m³ container, various crane options. For more detailed information, see the chipper brochure.

Kesla's selection of grapples and harvester heads includes solutions for equipping a tractor as an effective harvester. For more detailed information, see the harvester brochure.

Wide range of options and accessories to match your needs

Kesla equips tractors with effective and versatile solutions. In addition to the comprehensive and carefully considered standard equipment, Kesla also offers a wide range of accessories that provides a productive solution for all requirements.



KESLA WOOD GRAPPLES PROG 20/25/28/30

Kesla's grapples collect industrial and energy wood effectively regardless of location, whether it be the northern coniferous forest zone or a eucalyptus plantation in the south. The grapple jaws effortlessly penetrate woodpiles and straighten out crossed logs. Picking up individual logs without soil is easy.

TECHNICAL SPECIFICATIONS	20	25	28	30
Weight	70 kg	110 kg	170 kg	205 kg
Area	0.18 m ²	0.24 m ²	0.27 m ²	0.3 m ²
Working pressure	17.5 Mpa	19 Mpa	25 Mpa	25 Mpa
Gripping force	7 kN	10 kN	13 kN	16 kN
Opening time (50 l/min)	0.6 s	0.9 s	1.1 s	1.3 s
Closing time (50 l/min)	1.0 s	1.3 s	1.6 s	1.9 s
Max. opening	1235 mm	1315 mm	1609 mm	1567 mm
Min. opening	65 mm	70 mm	100 mm	100 mm
Max. width	320 mm	345 mm	480 mm	450 mm

ENERGY WOOD GRAPPLE KESLA PROG 25E/25P/30E

Kesla's energy wood grapples have been designed to handle mixed wood mass. Their broad and sturdy structure makes for smooth working, and extraneous materials do not get mixed in with wood mass. The grapples are excellent for energy wood handling and chipper feeding.

TECHNICAL SPECIFICATIONS	25P	25E	30E
Weight	110 kg	120 kg	245 kg
Area	0.2 m ²	0.15 m ²	0.21 m ²
Working pressure	19 Mpa	19 Mpa	25 Mpa
Gripping force	11 kN	11 kN	18 kN
Opening time (50 l/min)	0.9 s	0.9 s	1.1 s
Closing time (50 l/min)	1.3 s	1.3 s	1.6 s



KESLA MATERIAL GRIPPER

Mounted on KESLA timber grapples, the material gripper is well suited to the handling of chopped firewood, rocks, tree stumps, fresh feed, dry hay and other similar materials.

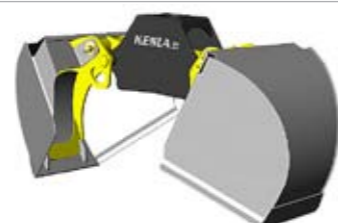

KESLA GRAVEL BUCKET

Mounted on KESLA timber grapples, the gravel bucket is suitable for loading soil or clearing ditches. Thanks to the narrow shape of the tip, the bucket sinks well into the ground. Connecting and disconnecting the bucket is quick and easy.

TECHNICAL SPECIFICATIONS	20	25
Bucket system		
Weight kg	53	85
Volume l	150	230
Width Max. mm	800	900
Width Min. mm	420	450
Grabber system		
Weight kg	33	52
Width mm	650	700

FELLING HEAD KESLA 19GX

The KESLA 19GX felling head is designed for felling and loading energy wood. Its straightforward structure and operating principle make it extremely dependable. Switching the felling head in the loader is quick since no additional hosing or wiring is required. An ingenious tilt function is integrated into the device, letting the operator decide when the tree falls. The felling head's blade is easy to switch off, after which the head can be used for loading just like a normal grapple. KESLA 19GX is used with the KESLA 200-500 Series loaders.

TECHNICAL SPECIFICATIONS	19GX
Max. cutting diameter	180 mm
Grapple opening	770 mm
Max. pressure	19 Mbar
Recommended oil flow	40-60 l/min
Weight	185 kg

KESLA EXCAVATION ACCESSORIES (FOR MODELS 211-203T)

Excavation accessories turn a KESLA loader into a versatile and effective excavator, expanding a tractor's functional capabilities in agriculture as well as forestry. No special tools are required when attaching the excavation accessories. Options include a V bucket and drain bucket.

TECHNICAL SPECIFICATIONS	EXCAVATION ACCESSORIES
Bucket volume	
V bucket	120 l
Drain bucket	60 l
Bucket width	
V bucket	1100/180 mm
Drain bucket	330 mm
Breaking force at bucket tip	20 kN/175 bar
Weight	
Excavator boom and cylinder	63 kg
V bucket	86 kg
Salaojakauha	64 kg



KESLA WINCH K1400

KESLA winch significantly increases a loader's reach. A radio-controlled control system facilitates, for example, the dragging of tree trunks at distances of up to 40 metres. Precise radio-control ensures that working the winch is safe. The KESLA winch is also extremely useful in felling trees at difficult and dangerous places. All KESLA 200 and 300 Series loaders are prepared for winch installation as part of the standard delivery.

TECHNICAL SPECIFICATIONS	K1400
Weight	45
Pulling force kg/bar	1400/175
Pulling speed m/min	27
Wire diameter mm/length m	6/40



WEIGHING SYSTEM

The precise, reliable and easy-to-use wireless scale installed in the loader's grapple link enables real-time weighing of the load.

STABILISER LEG OPTIONS

Kesla offers a range of stabiliser legs that will provide your combination with real stability. Durable stabiliser legs offer reliable operation.

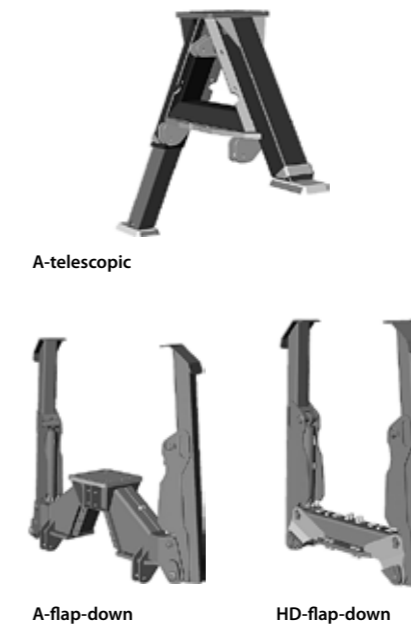

TOP SEAT EQUIPMENT

Installed on the loader's pillar, top control equipment gives the driver an open field of vision for demanding work.



ADDITIONAL HYDRAULIC UNIT

Installed in a KESLA timber trailer or loader, the additional hydraulic unit enables effective working even without tractor hydraulics. The additional hydraulic unit can power loaders and timber trailers.



STROKE DELIMBER KESLA 40LF

KESLA 40LF stroke delimeter used in combination with a KESLA loader forms an effective tool for timber delimiting, crosscutting and bunching. The stroke delimeter can be integrated with the loader's stabiliser frame or can be installed on a timber trailer or on a tractor's 3-point hitch. Using the KESLA 40LF stroke delimeter is quick and easy, with the choice of mechanical control valve or electrohydraulic pilot control.

TECHNICAL SPECIFICATIONS	40LF
Delimiting diameter	350 mm
Cutting diameter	400 mm
Feed cylinder stroke	1000 mm
Delimiting power, pressure 210 bar	
Cylinder diameter 40 mm	25,8 kN
Cylinder diameter 50 mm	40,8 kN
Delimiting speed, cylinder out (50 l/min)	
Cylinder diameter 40 mm	0,66 m/s
Cylinder diameter 50 mm	0,44 m/s
Delimiting speed, cylinder in (50 l/min)	
Cylinder diameter 40 mm	1,20 m/s
Cylinder diameter 50 mm	0,80 m/s
Slewing angle	260 °
Slewing torque	1100-2200 Nm
Tilt	
Blade head	15 "
Saw head	5 "
Hydraulic saw	
Saw chain	404 "
Saw plate length	16 "
Feed speed (50 l/min)	38 m/s
Power, pressure 175 bar (50 l/min)	12 kW
Weight kg	540 kg
Pump recommendation	
Output	45-50 l/min
Working pressure	175-210 bar
Power requirement	16-18 kW



WORKING LIGHTS

KESLA loader's boom can be fitted with working lights. Thanks to the powerful working lights, working without daylight is not a problem.

The right control system increases effectiveness and comfort of use

Selecting the right control system ensures that the loader and trailer will work together effectively and reliably. Components made by the sector's leading valve manufacturers form the basis for Kesla's control systems. From Kesla's extensive range, you can choose the mechanical, hydraulic or electrohydraulic control valves that best satisfy the requirements set by the nature of the work, the output and pressure of the tractor's hydraulics, and the loader-trailer combination. Connecting and disconnecting a loader equipped with a pilot control valve and a tractor is easy and effortless.



After-sales service and support

Kesla strongly invests in the continuous development of spare-parts and maintenance services and the service level of authorised sales locations and service centres worldwide. The eKESLA online after-sales service facilitates easy ordering of spare parts and quick handling of warranty claims.



MECHANICAL CONTROL VALVE RS-217, RS-218

KESLA loaders can be fitted with mechanical control valves. The valve structure and the smooth movements of the twin-joystick system enhance the controls' effectiveness, precision and sensitivity.

MECHANICAL CONTROL VALVE WALVOIL ON/OFF

The mechanical twin-joystick control valve is also available with an electric on/off control for grapple and extender.



ELECTROHYDRAULIC PILOT CONTROL WALVOIL, DANFOSS PVG32 AND PARKER L90LS

Electrohydraulic pilot control facilitates the effective simultaneous utilisation of separate control functions. Control independent of the loading brings precision and power to individual functions. Electrohydraulic pilot control enables diverse function-specific adjustment settings and, depending on the system, also saves driver-specific control and adjustment settings. Installing the pilot control joysticks in the tractor seat arm rests improves ergonomics and productivity.



HYDRAULIC PILOT CONTROL WALVOIL

Hydraulic pilot control facilitates the hydraulic control of main functions such as the lifting and outer boom, rotator and slew mechanism. The control of the grapple, extender boom and stabiliser legs are electrohydraulic. The solution achieves excellent ergonomics as well as smoothness and precision for the controls.



RADIO-CONTROL SCANRECO

The radio-controlled KESLA loader gets right to the core of work. In commercial work, for example, the loader can be controlled right from next to the bucket.

KESLA LOADER ACCESSORIES AND OPTIONAL EQUIPMENT

x = Standard o = Accessory v = Optional

LOADERS	211	202	202T	203T	204T	303	304	304T	305	305T	500	500T	500Z
Installation options													
on the beam of a KESLA timber trailer	v	v	v	v	v	v	v	v	v	v	v	v	x
on the rear axle of a tractor	v	v	v	v	v	v	v	v	v	v	v	v	-
on a tractor's 3-point hitch device	v	v	v	v	v	-	-	-	-	-	-	-	-
Valve options													
Mechanical twin-joystick control, RS-217/218	x	x	x	x	x	x	x	x	x	x	x	x	x
Mechanical twin-joystick control, electr. on/off for grapple and extender	o	o	o	o	o	o	o	o	o	o	o	o	-
Hydraulic pilot control	o	o	o	o	o	o	o	o	o	o	o	o	-
Electric pilot control	o	o	o	o	o	o	o	o	o	o	o	o	-
Dual damper	o	o	o	o	o	o	o	o	o	o	o	o	-
Stabiliser leg options													
Telescopic legs	o	o	o	o	o	o	o	o	o	o	o	o	-
Flap-down legs	o	o	o	o	o	o	o	o	o	o	o	o	x
Rotators													
FR 7	x	x	x	x	x	x	-	-	-	-	-	-	x
FR 10	o	o	o	o	o	o	x	x	-	-	-	-	o
FR 15	o	o	o	o	o	o	o	o	x	x	x	x	o
FR15W	-	-	-	-	-	-	o	o	o	o	-	-	-
Indexator GV6F	-	-	-	-	-	-	o	o	o	o	o	o	-
Brake link	o	o	o	o	o	x	x	x	x	x	x	x	o
Grapple													
KESLA proG 20	x	x	x	x	x	x	o	o	o	o	-	-	x
KESLA proG 25	o	o	o	o	o	o	x	x	x	x	x	x	o
KESLA proG 28	-	-	-	-	-	-	o	o	o	o	o	o	-
KESLA proG 25E	o	o	o	o	o	o	o	o	o	o	o	o	o
KESLA proG 25P	o	o	o	o	o	o	o	o	o	o	o	o	o
Accessories													
KESLA hydraulic winch, radio-controlled	o	o	o	o	o	o	o	o	o	o	o	o	o
KESLA 19GX energy grapple	o	o	o	o	o	o	o	o	o	o	o	o	o
1/2" hoses for double extender	-	-	-	-	-	-	-	o	-	o	-	-	-
Roller guide hose for electric cable	-	-	-	-	-	-	-	o	-	o	-	-	-
Working lights 2 pcs for transfer boom	o	o	o	o	o	o	o	o	o	o	o	o	o
Material gripper	o	o	o	o	o	o	o	o	o	o	o	o	o
Gravel bucket	o	o	o	o	o	o	o	o	o	o	o	o	o
Excavator boom equipment, V bucket and drain bucket	o	o	o	o	-	-	-	-	-	-	-	-	-
KESLA 60 additional hydraulic unit	o	o	o	o	o	o	o	o	o	o	o	o	o
Specialty colour for loader	o	o	o	o	o	o	o	o	o	o	o	o	o
Lift cylinder guard	-	-	-	x	x	x	x	x	x	x	x	x	-
Weighing system	-	-	-	-	-	o	o	o	o	o	o	o	-
Compatible with KESLA 40 LF stroke delimeter 50 l/min	o	o	o	o	o	o	o	o	o	o	-	-	-

KESLA timber trailers are known for their durability

Kesla is the world's leading manufacturer of timber trailers with over 30 years of experience. Kesla has the largest selection of timber trailers for use with tractors for timber harvesting and transport. The comprehensive selection has a perfect solution for every user.

KESLA timber trailers are made to withstand heavy year-round use, which is why they undergo rigorous quality and safety testing. The stability, load-carrying capacities, drive and terrain handling characteristics of KESLA timber trailers are superb. The trailer's drive path remains steady and it readily obeys the driver. In demanding timber harvesting, Kesla is the best partner, one famous for its durability.



STRONG STRUCTURE

KESLA trailers have a sturdy single-beam frame and strong articulated tow bar, which make the trailer agile and easy to control. The strong stabilizer legs bring added stability to loading, with a choice between telescopic and flap-down legs. Everything you need comes in a compact and easy-to-service package. The load space has been maximised and has good visibility.

DIVERSE TRANSMISSION OPTIONS

KESLA trailers have several transmission options available depending on the model, ranging from simple roller drive to fully mechanical or hydrostatic-mechanical drive and wheel motor drive. KESLA ND, MD and MDH timber trailers can also be fitted with chains or tracks to improve traction and carrying capacity. The combination's productivity rises to whole new spheres.

VERSATILE BRAKE SYSTEMS

Effective two- and four-wheel brakes increase safety in traffic and challenging terrains. The brakes are hydraulic or pneumatic control.

ROAD-TRAFFIC EQUIPMENT

Road-traffic equipment will get noticed on the roads, and the lights and warning triangle can be easily folded away to protect them from damage in the forest. Safety and comfort of use for the road

Carrying capacity, agility and drive

Kesla has the largest selection of timber trailers with 15 models with 8–12 tonne net loadings. KESLA timber trailers offer genuine load-carrying capacity in all conditions. The wide-motion tandem axle, single-beam frame and diverse tyre selection provide excellent handling characteristics in difficult terrain in the summer and winter.

All KESLA timber trailers are equipped with a hydraulic articulated tow bar that improves agility and productivity. In addition to models without drives, Kesla's selection also includes two- or four-wheel driven timber trailers that are also equipped with hydraulic roller drive or wheel motor drive. Models equipped with mechanical or hydrostatic-mechanical drives are also part of Kesla's selection. Of course, all KESLA timber trailers can be fitted with brakes.



TECHNICAL SPECIFICATIONS	82	92	92L	92HD	92LHD	10T	102H	102HD	102ND
Max. load	8 ton	9 ton	9 ton	9 ton	9 ton	10 ton	10 ton	10 ton	10 ton
Weight (incl. front screen, beam control and extra bunk)	1 050 kg	1 200 kg	1 215 kg	1 360 kg	1 375 kg	1 490 kg	2 050 kg	2 180 kg	2 250 kg
Total length	5 570 mm	5 570 mm	6 020 mm	5 570 mm	6 020 mm	6 050 mm	6 275 mm	6 275 mm	6 275 mm
Total width	2 080 mm	2 210 - 2 425 mm	2 210 - 2 425 mm	2 210 - 2 425 mm	2 210 - 2 425 mm	2 260 mm	2 460 - 2 600 mm	2 460 - 2 600 mm	2 460 - 2 600 mm
Load space area	1,7 m ²	1,7 m ²	1,7 m ²	1,7 m ²	1,7 m ²	2,4 m ²	2,2 m ²	2,2 m ²	2,2 m ²
Load space length	3 450 mm	3 455 mm	3 905 mm	3 455 mm	3 905 mm	3 900 mm	4 000 mm	4 000 mm	4 000 mm
Ground clearance	510 mm	530 - 590 mm	530 - 590 mm	530 - 590 mm	530 - 590 mm	550 mm	550-660 mm	550-660 mm	550-660 mm
Bunks, standard	2	3	3	3	3	3	3	3	3
Hydraulic articulated tow bar	± 33°	± 33°	± 33°	± 33°	± 33°	± 40°	± 35°	± 35°	± 35°
Wheel size	400/60x15.5	400/60x15.5; 500/55x17	400/60x15.5; 500/55x17	400/60x15.5; 500/55x17	400/60x15.5; 500/55x17	400/60x15.5; 500/55x17	500/55x17; 400/55x22.5; 550/45x22.5; 600/50x22.5 550/45x22.5; 600/50x2.5	500/55x17; 400/55x22.5; 550/45x22.5; 600/50x22.5 550/45x22.5; 600/50x2.5	500/55x17; 400/55x22.5; 550/45x22.5; 600/50x22.5 550/45x22.5; 600/50x2.5
- ply	14	12-14	12-14	12-14	12-14	12-14	12-14	12-14	12-14
Drive power:	-	-	-	1,2 ton	1,2 ton	-	Drive accessory	1,4 ton	1,5-3,0 ton
- pressure	-	-	-	175 bar	175 bar	-	-	175 bar	175 bar
Max. drive speed with drive engaged	-	-	-	5,0 km/h	5,0 km/h	-	-	5,0 km/h	2,5/4,0 km/h
Loader recommendation	Kesla 211	Kesla 200 Series				Kesla 200 and 300 Series loaders			

Heavy-duty timber trailers

Kesla's 12-tonne timber trailers have been designed for professional use with even the largest tractors. Their terrain-operating characteristics are exceptional, and the line includes timber trailers with traction capacity of up to 5 tonnes. In difficult conditions, the terrain ability can be improved with chains or tracks. Drive release facilitates faster driving speeds in highway traffic. The mechanical 12MD/MDH trailer can be fitted with hydraulically controlled head rack, frame lock and a rear-axle mounted tow bar.



TECHNICAL SPECIFICATIONS	12T	12H	12HD	12ND	12MD	12MDH
Max. load	12 ton	12 ton	12 ton	12 ton	12 ton	12 ton
Weight (incl. front screen, beam control and extra bunk)	2 240 kg	2 750 kg	2 940 kg	3 000 kg	3 220kg	3 700 kg
Total length	6 050 mm	6 050 mm	6 050 mm	6 050 mm	6 210 mm	6 210 mm
Total width	2 550mm	2 500 mm	2 500 mm	2 500 mm	2 250 mm	2 250 mm
Load space area	3,15 m ²	3,15 m ²	3,15 m ²	3,15 m ²	3,15 m ²	3,15 m ²
Load space length	3 900 mm	3 900 mm	3 900 mm	3 900 mm	4 050 mm	4 050 mm
Ground clearance	510 mm	520 mm	520 mm	550 mm	530-560 mm	530-560 mm
Bunks, standard	4	4	4	4	4	4
Hydraulic articulated tow bar	± 40°	± 40°	± 40°	± 40°	± 40°	± 40°
Wheel size	550/45x22.5	550/45x22.5	550/45x22.5	550/45x22.5	400/55x22.5; 550/45x22.5	400/55x22.5; 550/45x22.5; 600/50x22.5
- ply	12-14	12-14	12-14	12-14	12-14	12-14
Drive power	-	Drive accessory	1,4 ton	1,5-3,0 ton*	5,3 ton	4,8 ton
- pressure	-	-	175 bar	175 bar	-	250 bar of trailer hydraulics
Max. drive speed with drive engaged	-	-	4,0 km/h	2,5/4,0 km/h	10,0 km/h	5,0 km/h
Loader recommendation	Kesla 300 and 500 Series loaders					

Efficient transport with accessories



HEAD RACK SUPPORT

Head rack support ties the front beams and the front screen into one bundle. The head rack firms up when timber bundles are piled against it.

MOVABLE HEAD RACK

In the most powerful trailers models (12MD/12MDH), the trailer is also available with a hydraulically controlled head rack. The ability to move the head rack enables moving the load's centre of gravity. The head rack's travel is 500 mm.



ADDITIONAL HYDRAULIC UNIT

Installed in a KESLA timber trailer or loader, the additional hydraulic unit enables effective working even without tractor hydraulics. The additional hydraulic unit can power loaders and a timber trailer.



TYRE OPTIONS

KESLA timber trailers can be fitted with a wide range of tyres that has the right tyre for every purpose.

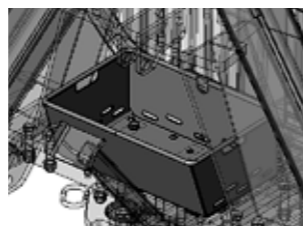

TOOL BOX

Tools needed at the site travel handily in the tool box Available in two versions, mounting either to the head rack or to the loader's A-frame.



LIGHT SET

The light set provides easy lighting on the road. The lights are easy to retract when moving off the road. KESLA-trailer will get noticed also on the road.

SLOW-MOVING VEHICLE SIGN

The slow-moving vehicle sign combined with lights provides visibility and safety in traffic.

FRAME EXTENSION

The frame extension can extend the load space length by 500–1,000 mm. The extension can be fitted with a bunk and posts. The frame extension is extremely useful for energy wood handling, transporting two short bundles of timber in tandem or transporting extra-long timber.

EXTRA BUNKS

An extra bunk and posts increase the sturdiness of the load space and facilitate tidy loads. Extra bunks can be freely added to the frame.



LOAD DIVIDERS

Load dividers facilitate partitioning the load space for different types of timber. Collect all timber along the same skid road.



BRAKES

KESLA timber trailers can be fitted with an extensive range of brakes, such as two- and four-wheel brakes operating hydraulically or pneumatically.



DRIVE

The drive selection is extensive. Hydraulic roller drive, hydraulic wheel motor drive, mechanical and hydrostatic-mechanical drives. There are drives for every purpose. Trailers with wheel motor drive or mechanical or hydrostatic-mechanical drive can also be fitted with anti-skid chains and tracks.

KESLA TIMBER TRAILERS ACCESSORIES AND OPTIONAL EQUIPMENT

x = Standard o = Accessory v = Optional

TIMBER TRAILERS	82	92L	92LHD	10T	102H	102HD	102ND	12T	12H	12HD	12ND	12MD	12MDH
Hydraulic articulation	x	x	x	x	x	x	x	x	x	x	x	x	x
Head rack support between the head rack and the first post	x	x	x	x	x	x	x	x	x	x	x	x	x
Tyre options													
400/60x15.5	x	x	x	x	-	-	-	-	-	-	-	-	-
500/55x17	-	v	v	v	x	x	x	-	-	-	-	-	-
400/55x22.5	-	-	-	-	v	v	v	-	-	-	-	v	v
550/45x22.5	-	-	-	-	v	v	v	x	x	x	x	x	x
600/50x22.5	-	-	-	-	v	v	v	x	x	x	v	x	x
Drive options													
HD roller	-	-	x	-	o	x	-	-	o	x	-	-	-
ND wheel motor drive	-	-	-	-	-	-	x	-	-	-	x	-	-
Mechanical drive	-	-	-	-	-	-	-	-	-	-	-	x	-
Hydrostatic-mechanical drive	-	-	-	-	-	-	-	-	-	-	-	-	x
Accessories													
Flap-down stabiliser legs	-	-	-	o	o	o	o	o	o	o	o	o	o
Mounting column for loader	-	-	-	o	o	o	o	o	o	o	o	o	o
Brakes	-	o	o	o	o	o	o	o	o	o	o	o	o
Bio-mass box	-	o	o	o	o	o	o	o	o	o	o	o	o
Frame extender	-	o	o	o	o	o	o	o	o	o	o	o	o
Electrical drive control valve	-	-	o	-	o	o	o	-	o	o	o	x	x
box for the front screen	o	o	o	o	o	o	o	o	o	o	o	o	o
box for the A-frame	o	o	o	-	-	-	-	-	-	-	-	-	-
Extra bunk and posts	o	o	o	o	o	o	o	o	o	o	o	o	o
Rear light	o	o	o	o	o	o	o	o	o	o	o	o	o
Slow-moving vehicle triangle	o	o	o	o	o	o	o	o	o	o	o	o	o
Load divider for post	o	o	o	o	o	o	o	o	o	o	o	o	o
Hydraulically controlled head rack and bunk	-	-	-	-	-	-	-	-	-	-	-	o	o
Rear-axle mounted tow bar with frame lock	-	-	-	-	-	-	-	-	-	-	-	o	-

The values provided by the manufacturer are indicative. Kesla reserves the right to make changes. The cranes and trailers shown may have additional accessories. Standard equipment and options may vary by country.

KESLA

