

SC18CL LBP/MBP Compressor R404A/R507 220-240V 50Hz

Data Sheet (Replaces CF.54.D1.02)

General

Compressor	SC18CL
Code number	104L2123

Application

Application	LBP/MBP	
Evaporating temperature range	°C	-45 to -5
Voltage range	V/Hz	198 - 254 /50
Motor type	CSR	
Max. ambient temperature	°C	38
Comp. cooling at ambient temp.	32°C	F ₂
	38°C	F ₂

Design

Displacement	cm ³	17.69
Oil quantity	cm ³	600
Maximum refrigerant charge	g	1300
Free gas vol. in compressor	cm ³	1460
Weight without electrical equipment	kg	13.7

Motor

Motor size	watt	495
LRA (rated after 4 sec. UL984) HST	A	20.0
Cut-in current HST	A	20.0
Resistance, main and start winding (25°C)	Ω	3.7/14.1
Approvals	EN 60335-2-34	

Dimensions

Height	mm	A	219
		B	213
		B1	193
		B2	110
Suction connector	location/I.D. mm	C	10.2 ±0.09
Process connector	location/I.D. mm	D	6.2 ±0.09
Discharge connector	location/I.D. mm	E	6.2 ±0.09
Compressors on a pallet	pcs.	80	

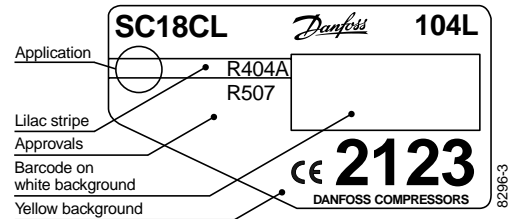

- S = Static cooling normally sufficient
- O = Oil cooling
- F₁ = Fan cooling 1.5 m/s
(compressor compartment temperature equal to ambient temperature)
- F₂ = Fan cooling 3.0 m/s necessary

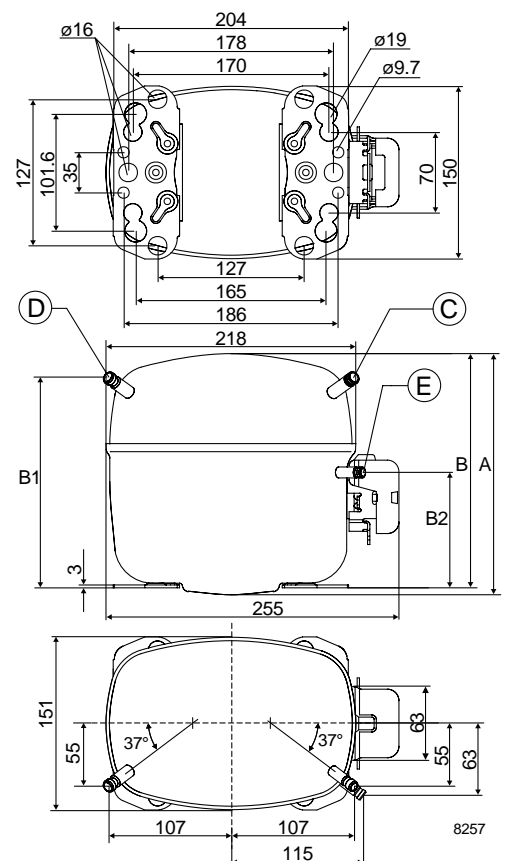

Capacity (EN 12900/CECOMAF)

watt

Comp. °C	-45	-40	-35	-30	-25	-23.3	-20	-15	-10	-5
SC18CL	167	271	395	542	715	781	918	1154	1425	1735

Capacity (ASHRAE)

watt

Comp. °C	-45	-40	-35	-30	-25	-23.3	-20	-15	-10	-5
SC18CL	193	313	457	628	830	907	1067	1342	1659	2022

Power consumption

watt

Comp. °C	-45	-40	-35	-30	-25	-23.3	-20	-15	-10	-5
SC18CL	294	376	455	534	615	643	700	792	894	1008

Current consumption

A

Comp. °C	-45	-40	-35	-30	-25	-23.3	-20	-15	-10	-5
SC18CL	2.61	2.80	3.02	3.29	3.60	3.72	3.96	4.36	4.80	5.29

COP (EN 12900/CECOMAF)

W/W

Comp. °C	-45	-40	-35	-30	-25	-23.3	-20	-15	-10	-5
SC18CL	0.57	0.72	0.87	1.01	1.16	1.21	1.31	1.46	1.59	1.72

COP (ASHRAE)

W/W

Comp. °C	-45	-40	-35	-30	-25	-23.3	-20	-15	-10	-5
SC18CL	0.66	0.83	1.00	1.18	1.35	1.41	1.52	1.69	1.86	2.01

Test conditions	EN 12900/CECOMAF	ASHRAE
Condensing temperature	45°C	45°C
Ambient and suction gas temp.	32°C	32°C
Liquid temperature	45°C	32°C
Fan cooling F ₂ , 220V 50Hz		

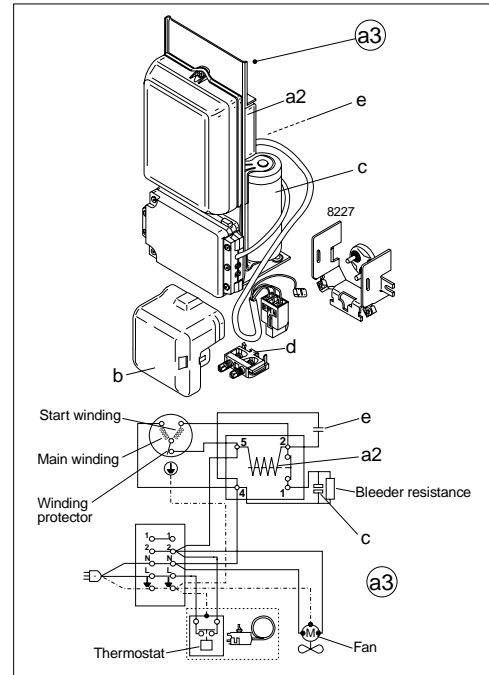

Accessories

Devices	Fig.	SC18CL
Starting device	a3	117-7012 (470 mm cable length) 117-7027 (550 mm cable length) 117-7046 (650 mm cable length) 117-7040 (1000 mm cable length)
Cover	b	103N2009
Starting relay	a2	Components of starting device
Starting capacitor 80 µF	c	
Run capacitor	e	
Cord relief	d	103N1004
Mounting accessories		
Bolt joint for one compressor		118-1917
Bolt joint in quantities		118-1918
Snap-on in quantities		118-1919