

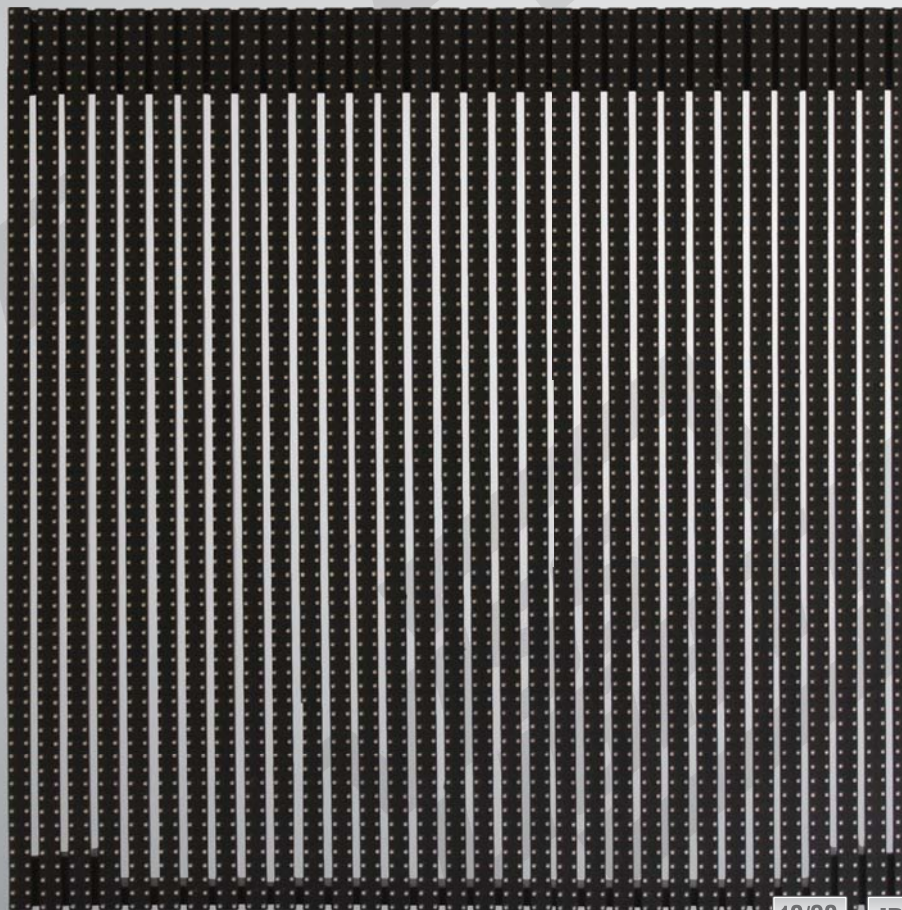

# KINGKONG10/20



## DIMENSIONS

All dimensions are in millimeters

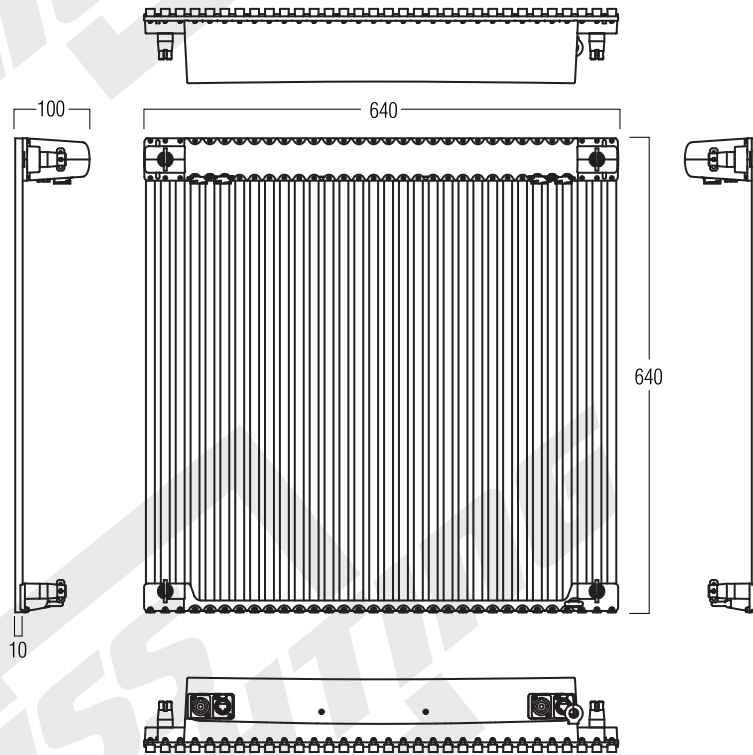

## SPECIFICATIONS

| Specifications                         | KINGKONG10                      | KINGKONG20 |
|--|---------------------------------|------------|
| Pixel Pitch                            | 10mm                            | 20mm       |
| Pixel Matrix                           | 64X64 dot                       | 32X32 dot  |
| Led quantity/Module                    | 4096 dot                        | 1024 dot   |
| Pixel Configuration                    | SMD 3-IN-1                      |            |
| Brightness                             | 3000-5000nit                    | 4200 nit   |
| Data Refresh Rate                      | 1440Hz                          | 1920Hz     |
| Gray Scale                             | 14bit                           |            |
| Color                                  | 68.7 billion                    |            |
| Brightness Adjustment                  | 8 grades adjustable on software |            |
| Unit Size                              | 640X640X100mm                   |            |
| Unit Area                              | 0.41m <sup>2</sup>              |            |
| Unit Weight                            | 9kg                             | 8kg        |
| Max Power Consumption/Unit             | 300W                            | 200W       |
| Viewing Angle(horizontal/vertical)     | 120°/120°                       | 140°/140°  |
| Minimum View Distance                  | 10m                             | 20m        |
| Transparency                           | 21%                             | 40%        |
| Out-of-control Point                   | <0.0002                         |            |
| Tenure Life Of Lamp(50% Brightness)    | >50000 hours                    |            |
| Work Temperature                       | -10°C~+40°C                     |            |
| Relative Humidity                      | 10%~90% RH                      |            |
| Protection Level                       | IP65                            |            |
| Work Voltage                           | AC100~240V / 50~60Hz            |            |
| Drive Mode                             | Constant Current                |            |
| Operating System                       | Windows (2000/XP/Vista/win7)    |            |
| Signal Types(adopting video processor) | AV,S-Video,VGA,CVBS,HDMI,DVI    |            |
| Control Distance                       | HSYV;<100m                      |            |
| Certificate                            | CE                              |            |

## PRODUCT FEATURES

### **Die-cast aluminum alloy**

Whole die-cast aluminum reduces spare parts, strengthen sability, and make simple structure and durable lifespan. Every light strip uses die-cast aliminum alloy material and transparency surrounding, which makes good dissipation.



## Easy installation

Unique auto-locking design makes installation easy and maintenance super convenient and flexible. One person can handle these freely.

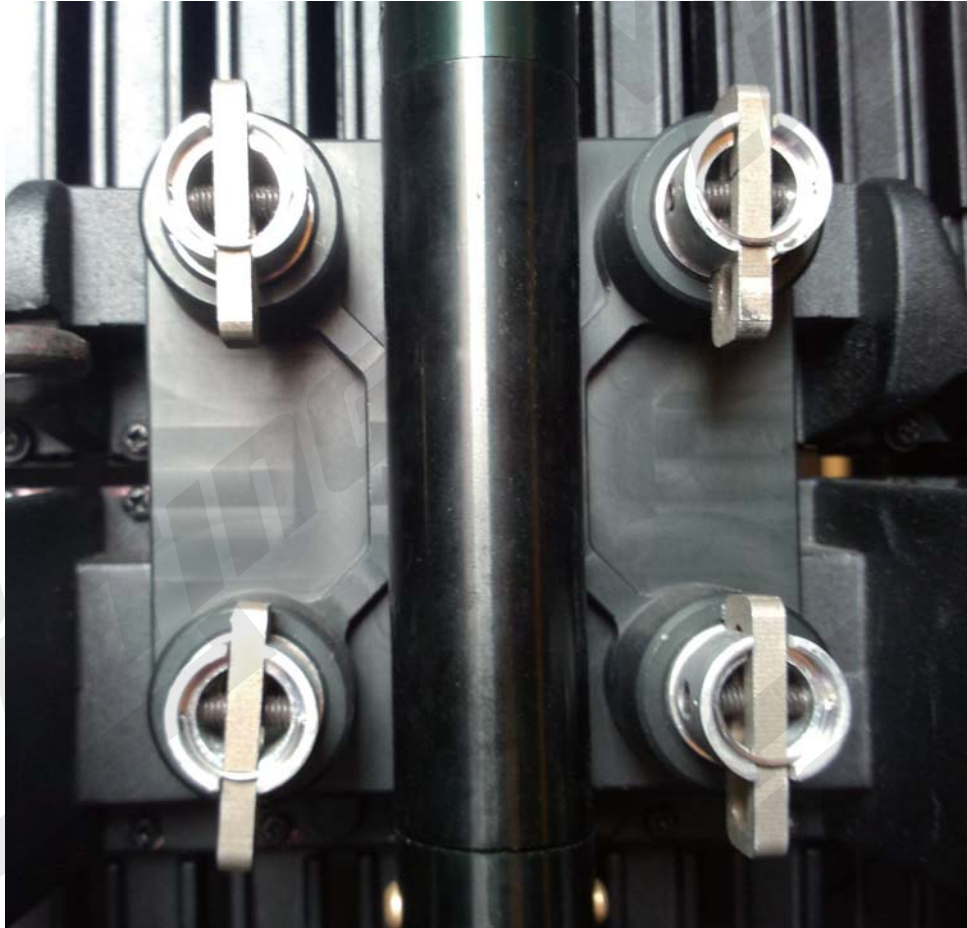

**High protection level**

IP 65 protection level, suits all kinds of outdoor show application.

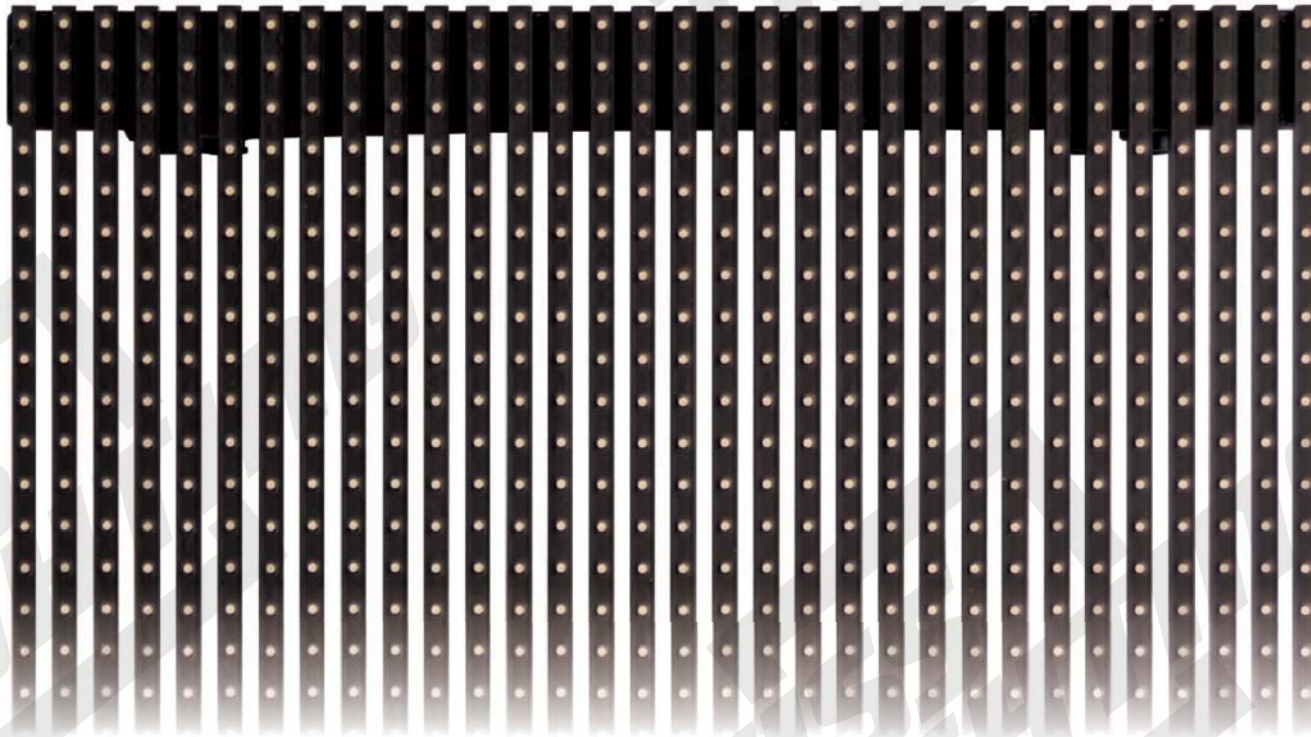

## High brightness, high transparency

The brightness can reach to 5000nit, it also has excellent performance at the bright places. High transparency with 40% makes strong resistance of wind.

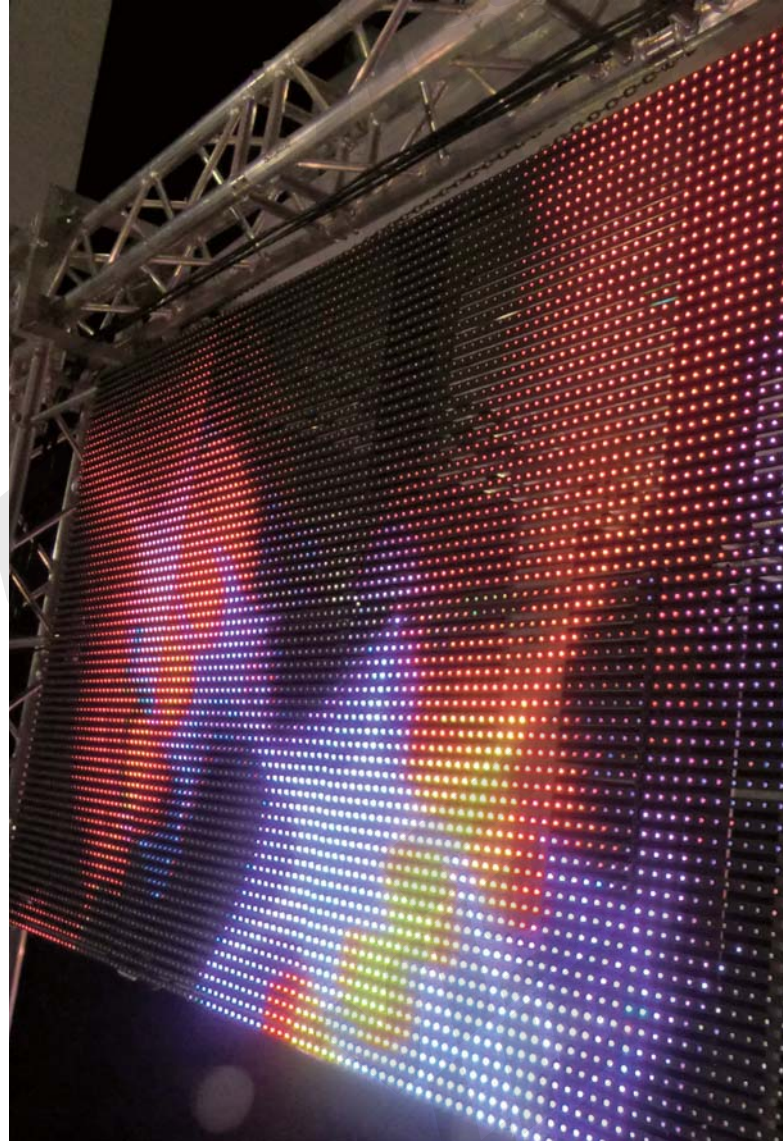

# SHOWCASE

