

FLANGED H TYPE STRAINER

TECHNICAL PASSPORT

PN10/16 FLANGED H TYPE STRAINER DUCTILE IRON BODY

F4240

APPLICATION

The basket strainer is intended for installation in water pumping and distribution installations where effective filtration is required.



Fluids: clear water, compatible liquids.

GENERAL CHARACTERISTICS

Range: from DN40 to DN600.

- Compact and robust body
- Easily removable cover for maintenance
- ISO flanges for pipe mounting.
- Installation in all positions possible (optimum position obtained with horizontal drain and cover positioned at the top).
- Food epoxy coating



CONSTRUCTION

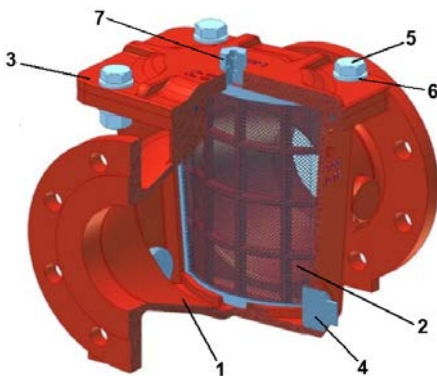

Pos.	Description	Material
1	Body	Ductile iron GGG40
2	Screen	Stainless steel 316
3	Cover	Ductile iron GGG40
4	Plug	Stainless steel 316
5	Screw	Stainless steel 303
6	Washer	Stainless steel 303
7	Drain plug	Stainless steel 303

STANDARDS

Connection	With flanges PN10/16 (DN40-150) and PN16 (DN200-600) according to EN1092-2 standard
------------	---

Tecofi France

83 rue Marcel Mérieux - 69960 Corbas
Tél. +33 (0)4 72 79 05 79 - Fax. +33 (0)4 78 90 19 19
E-mail : sales@tecofi.fr - www.tecofi.fr



FLANGED H TYPE STRAINER

TECHNICAL PASSPORT

F4240

DIMENSIONS

Minimum space to dismantle the screen

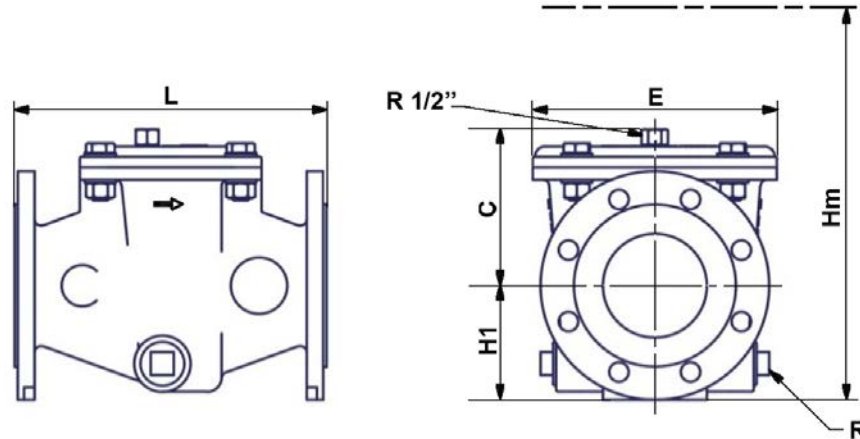

DN		L	H1	C	E	Hm	R	Weight (kg)
mm	inch							
40/50	1"1/2/2"	230	82.5	125	200	340	R1"1/4	13.8
60/65	2"1/4/2"1/2	230	92.5	96	200	340	R1"1/4	14.6
80	3"	300	103	150	235	450	R1"1/4	22
100	4"	300	110	150	235	450	R1"1/4	23
125	5"	400	125	215	380	620	R1"1/4	46
150	6"	400	143	196	380	620	R1"1/4	48
200	8"	500	170	230	440	700	R1"1/4	76
250	10"	580	225	310	560	950	R1"1/4	165
300	12"	610	227.5	385	680	1150	R2"	230
350	14"	650	260	380	680	1150	R2"	250
400	16"	800	310	500	900	1430	R2"	410
450	18"	800	335	500	900	1430	R2"	430
500	20"	950	485	609	1190	2070	R3"	770
600	24"	1100	485	609	1190	2070	R3"	850

WORKING CONDITIONS

Maximum working pressure : 16 bar
 Maximum working temperature : +80°C

Tecofi France

83 rue Marcel Mérieux - 69960 Corbas
 Tél. +33 (0)4 72 79 05 79 - Fax. +33 (0)4 78 90 19 19
 E-mail : sales@tecofi.fr - www.tecofi.fr



FLANGED H TYPE STRAINER

TECHNICAL PASSPORT

F4240

HEAD LOSS DIAGRAM

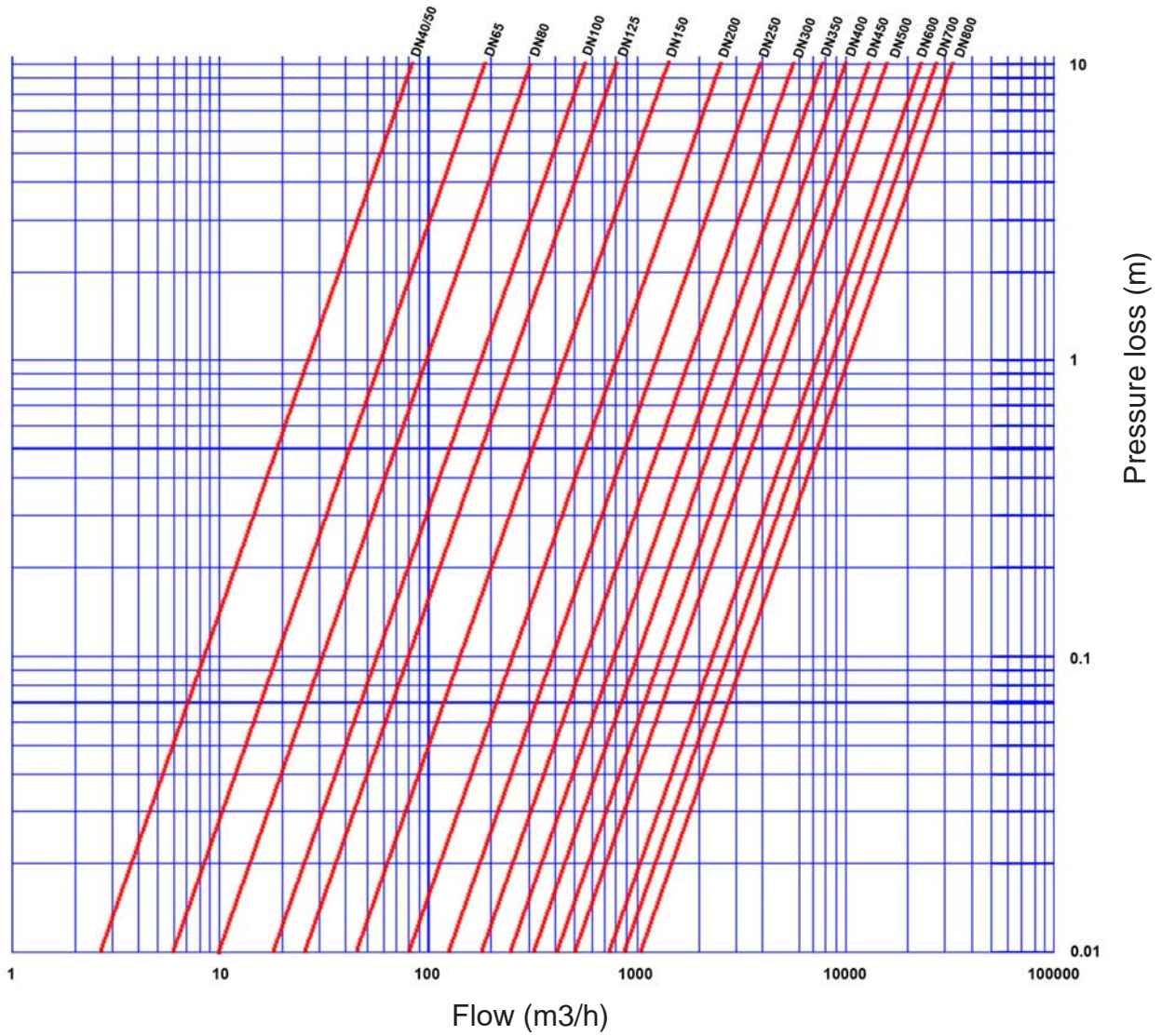

The photographs and technical art works are not contractual. The specifications of the presented products are open to modifications without previous advice

Tecofi France

83 rue Marcel Mérieux - 69960 Corbas
Tél. +33 (0)4 72 79 05 79 - Fax. +33 (0)4 78 90 19 19
E-mail : sales@tecofi.fr - www.tecofi.fr

