

RUBBER EXPANSION JOINT TEGUFLEX® PU YELLOW ECO FLANGED PN10/16

Rubber expansion joint Teguflex ECO with swiveling flanges to absorb vibrations and noises on water networks with salt solutions, alkalis, mineral oils, vegetable and animal oils, oil aerosols, butane and propane gas, compressed air.

Not advisable for aromatic and chlorinated solvent networks.

Body in Epichlorhydrin (ECO) and carbon steel dichromate zinc plated or AISI 316 flanges.

For linear and angular compansion.

130 mm long for all DN.



Size : DN25 to DN300

Connection : Flanges PN10/16

Min Temperature : -25°C

Max Temperature : +90°C

Max Pressure : 16 Bars (10 bars at 90°C)

Specifications : Absorb vibrations and noise
Linear and angular compansion
Epichlorhydrin tube (ECO)

Materials : Dichromate zinc plated steel flanges

RUBBER EXPANSION JOINT TEGUFLEX® PU YELLOW ECO FLANGED PN10/16

SPECIFICATIONS :

- Absorb vibration, noises and expansion
- Linear and angular compansion
- Inner tube Epichlorhydrin (ECO)
- 130 mm length
- Dichromate zinc plated steel swiveling flanges PN10/16 up to DN150, PN10 over
- On request, PN6, PN16 and Class 150 PN20 flanges
- AISI 316 flanges on request
- AISI 316 Ti vacuum ring on request (Ref.9815050 to 9815300)
- Inner liner PTFE on request (movements allowed by the expansion joints are then reduced by 50 % and pressure max is 6 bars)
- Bursting pressure >50 bar at 20°C
- Test pressure 25 bar at 20°C

USE :

- Water, salt water, alkalis, mineral oils, vegetal and animal oils, oils aerosols, butane or propane, gas
- Compressed air
- Not advisable for aromatic and chlorinated solvent
- Min and max temperature Ts : - 25°C to + 90°C
- Max pressure Ps : 16 bars at 70°C and 10 bars at 90°C (6 bars with PTFE lining)

PRESSURE / TEMPERATURE GRAPH (STEAM EXCLUDED) :

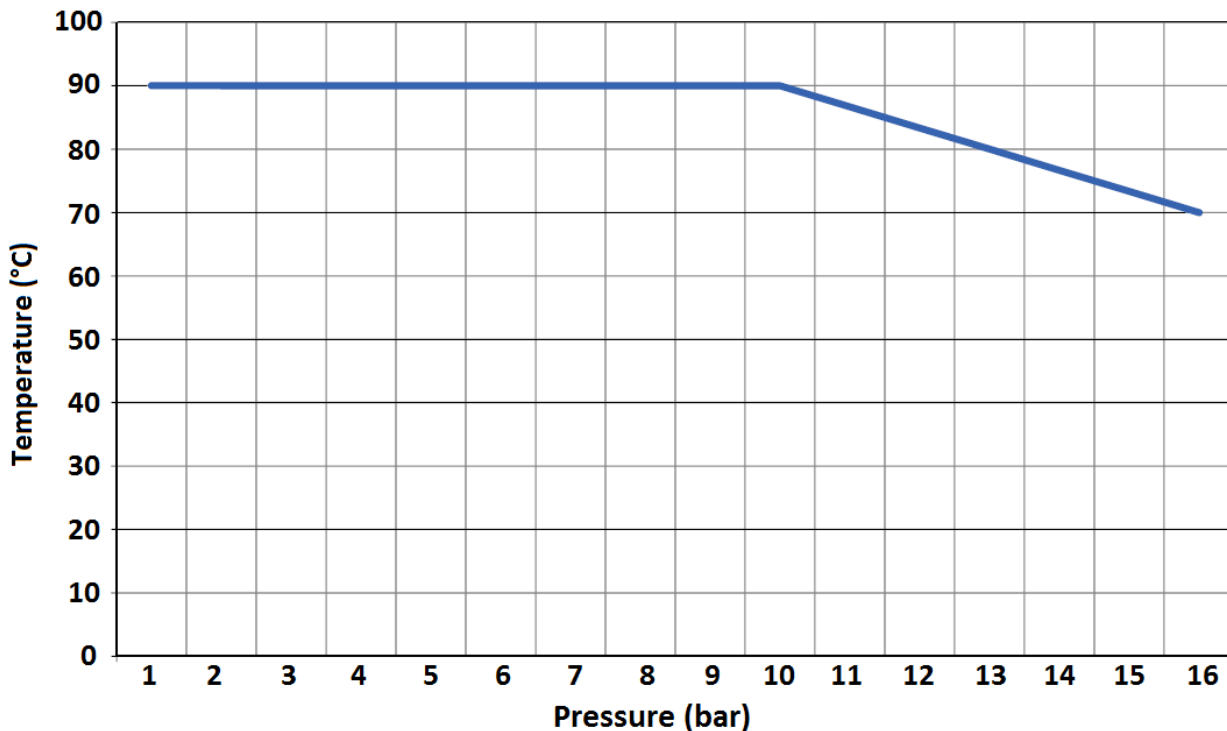

MAXIMUM VACUUM :

DN	25/32	40	50	65	80	100	125	150	200	250	300
Vacuum (bar)	-0.8	-0.8	-0.7	-0.6	-0.5	-0.5	-0.4	-0.3	-0.3	-0.2	-0.2

RUBBER EXPANSION JOINT TEGUFLEX® PU YELLOW ECO FLANGED PN10/16

RANGE :

- Epichlorhydrin (ECO) expansion joint with dichromate zinc plated steel flanges PN10/16 from DN 25 to DN 150, PN10 over **Ref. 1563**
- **On Request :**

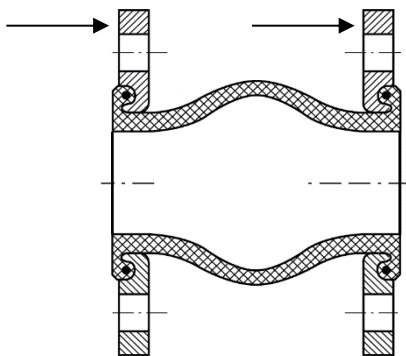

- AISI 316 flanges

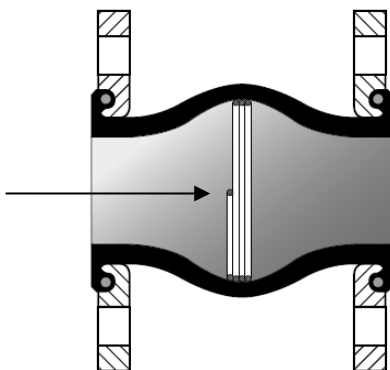

- AISI 316 Ti vacuum ring (vacuum up to -1 bar) Ref.9815050 to 9815300

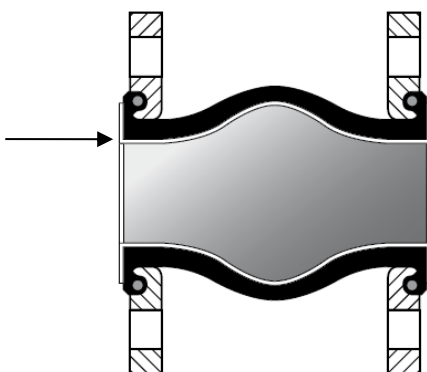

- Inner liner PTFE (movements allowed by the expansion joints are then reduced by 50 % and pressure max is 6 bars)

RUBBER EXPANSION JOINT TEGUFLEX® PU YELLOW ECO FLANGED PN10/16

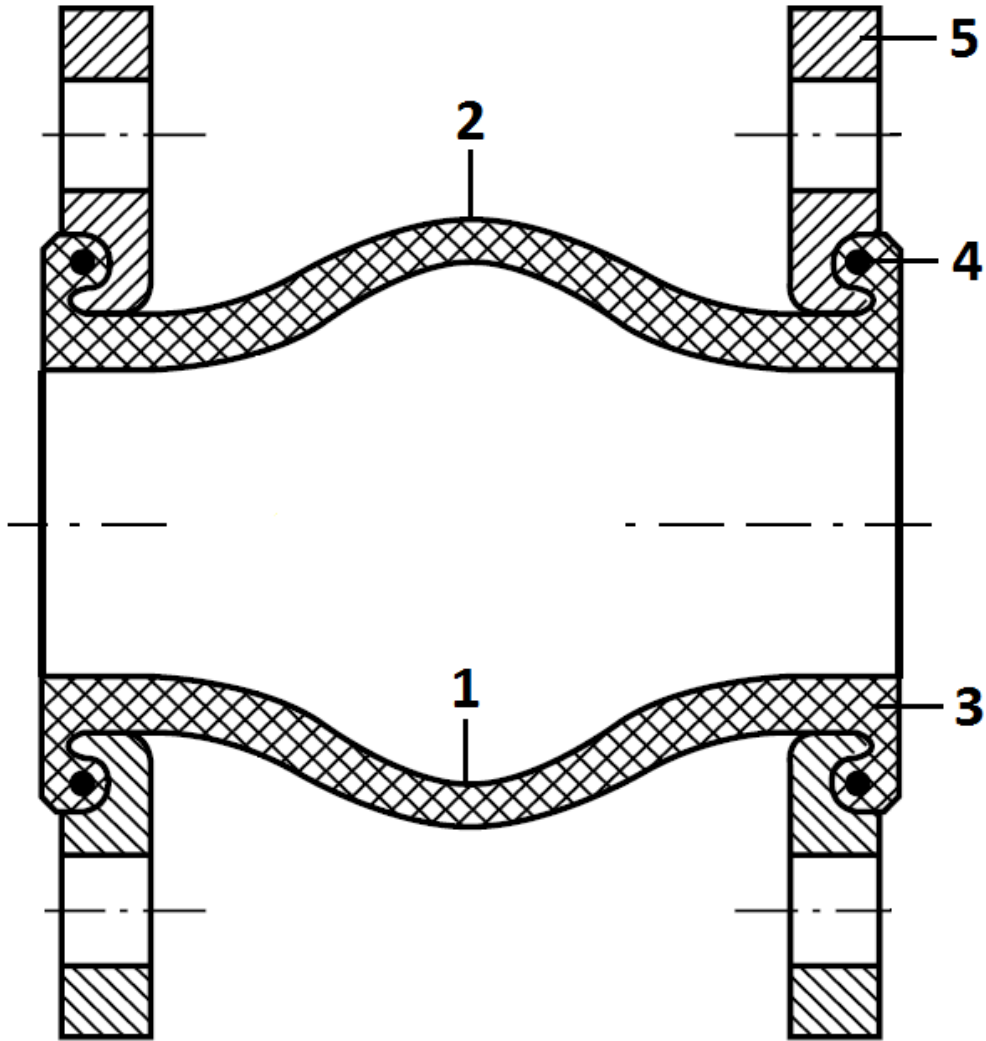
MATERIALS :

Item	Designation	Materials
1	Inner tube	Epichlorhydrin (ECO)
2	Outer cover	Epichlorhydrin (ECO)
3	Reinforcement	Synthetic textile
4	Brace	Carbon steel
5	Swiveling flanges	Dichromate zinc plated steel

RUBBER EXPANSION JOINT TEGUFLEX® PU YELLOW ECO FLANGED PN10/16

SIZE (in mm) :

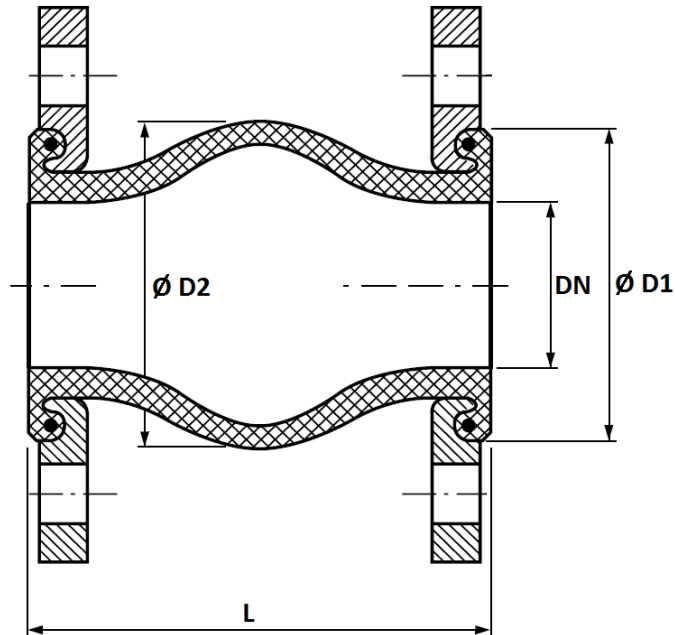

DN	25	32	40	50	65	80	100	125	150	200	250	300
L	130											
Ø D1	72		80	90	105	120	140	165	190	240	290	340
Ø D2	77		85	95	110	125	145	170	195	245	295	345
Weight (Kg)	1.8	2.8	3.3	3.7	4.8	5.3	6.2	8.2	11.2	16.8	21.6	30.1
Ref.	1562025	1563032	1563040	1563050	1563065	1563080	1563100	1563125	1563150	1563200	1563250	1563300

STANDARD FLANGES PN10 (PN10/16 UP TO DN150) SIZE (in mm) :

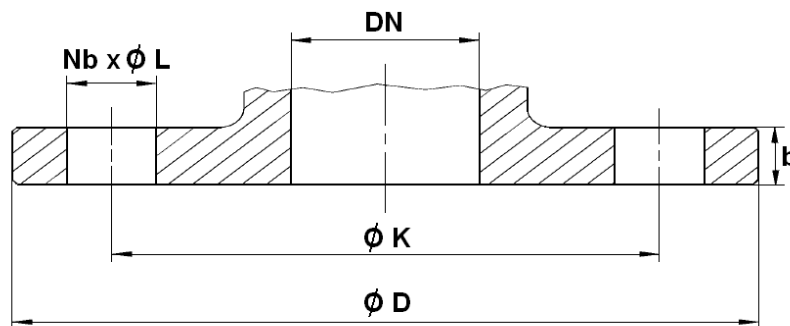

DN	25	32	40	50	65	80	100	125	150	200	250	300
Ø D	115	140	150	165	185	200	220	250	285	340	395	445
Ø K	85	100	110	125	145	160	180	210	240	295	350	400
Nb x Ø L	4x14	4 x 18	4 x 18	4 x 18	4 x 18	8 x 18	8 x 18	8 x 18	8 x 22	8 x 22	12 x 22	12 x 22
b	13.8	13.8	14	14.1	14.4	14.8	15.2	16	17.8	20.2	22.6	26.5

RUBBER EXPANSION JOINT TEGUFLEX® PU YELLOW ECO FLANGED PN10/16

SIZE OF FLANGES ON REQUEST :

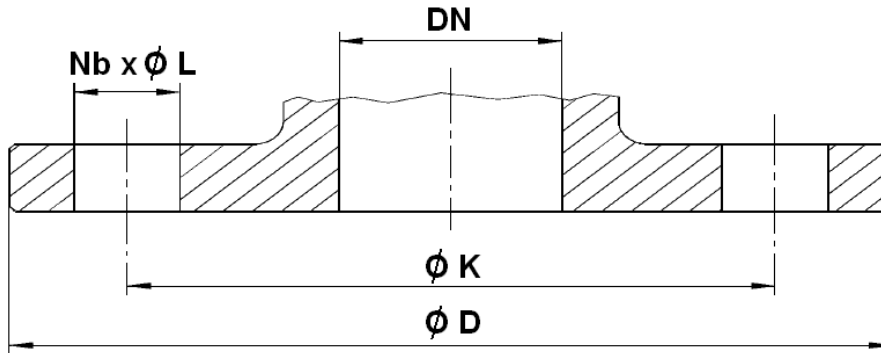

PN6 FLANGES (in mm) :

DN	25	32	40	50	65	80	100	125	150	200	250	300
Ø D	100	120	130	140	160	190	210	240	265	320	375	440
Ø K	75	90	100	110	130	150	170	200	225	280	335	395
Nb x Ø L	4 x 11	4 x 14	4 x 14	4 x 14	4 x 14	4 x 18	4 x 18	8 x 18	8 x 18	8 x 18	12 x 18	12 x 22

PN16 FLANGES (in mm) :

DN	200	250	300
Ø D	340	405	460
Ø K	295	355	410
Nb x Ø L	12 x 22	12 x 26	12 x 26

Class 150 PN20 FLANGES (in mm) :

DN (mm)	25	32	40	50	65	80	100	125	150	200	250	300
NPS (")	1"	1"1/4	1"1/2	2"	2"1/2	3"	4"	5"	6"	8"	10"	12"
Ø D	108	117	127	152	178	190	229	254	279	343	406	483
Ø K	79.4	88.9	98.4	120.6	139.7	152.4	190.5	215.9	241.3	298.4	361.9	431.8
Nb x Ø L	4 x 15.9	4 x 15.9	4 x 15.9	4 x 19	4 x 19	4 x 19	8 x 19	8 x 22.2	8 x 22.2	8 x 22.2	12 x 25.4	

RUBBER EXPANSION JOINT TEGUFLEX® PU YELLOW ECO FLANGED PN10/16

MOVEMENTS (in mm) :

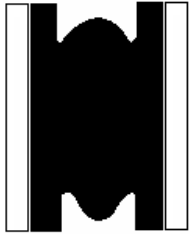

Compansion

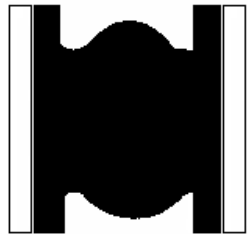

Expansion

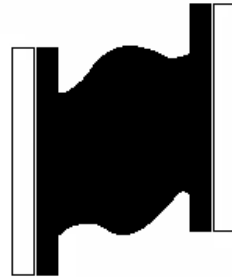

Lateral

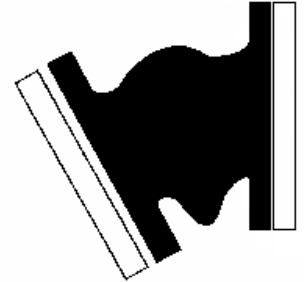

Angular

DN	25-50	65	80	100	125	150	200	250	300
Compansion	30	30	30	30	30	30	30	30	30
Expansion	20	20	20	20	20	20	20	20	20
Lateral	20	20	20	20	20	20	20	20	20
Angular	35°	30°	30°	25°	25°	15°	15°	10°	10°

Maximum movements can't be applied simultaneously.
 For example, with an expansion of 15mm, the maximum lateral movement will be 8 mm :

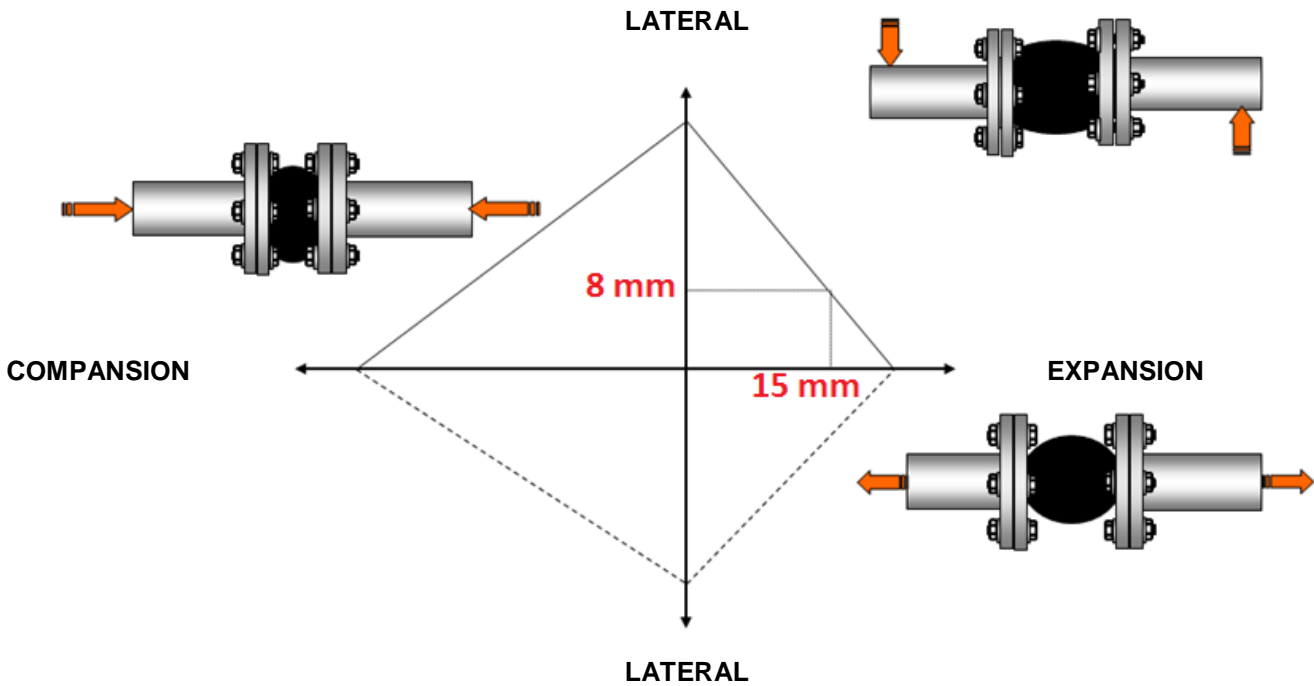

REF. 1563

RUBBER EXPANSION JOINT TEGUFLEX® PU YELLOW ECO FLANGED PN10/16

MARKING :



STANDARDS :

- Manufacturer certified ISO 9001 : 2015 and ISO 14001 : 2015
- DIRECTIVE 2014/68/EU : CE N° 0056
Risk category III Module H
- Flanges according to EN 1092-1 PN10/16
- **Marine ABS** Product type approved, Certificate N° 15LD1374164PDA
- **Marine DNV-GL** type Approval certificate, Certificate N° TAP000018F