

CARBON STEEL WAFER SWING CHECK VALVE EPDM

Wafer carbon steel swing check valve for heating and water distribution.

Carbon steel body and disc with EPDM seat.

Wafer type with short length and with a removable hoisting eye for easy installation.

Certificate

3.1



Size : DN40 to DN600

Connection : Between flanges PN10/16 up to DN150, PN16 over Class 150 (PN20) from DN100 to 400

Min Temperature : -10°C

Max Temperature : +110°C

Max Pressure : 16 Bars up to DN200, 10 bars over

Specifications : EPDM seat

Horizontal or vertical position with ascendant fluid

Wafer type

Removable hoisting eye

Weak headloss

Materials : Chromed Carbon Steel ASTM A216 WCB

CARBON STEEL WAFER SWING CHECK VALVE EPDM**SPECIFICATIONS :**

- Wafer swing check valve
- Vertical position with ascendant fluid or horizontal position (respect the flow direction indicated by the arrow)
- Between flanges PN10/16 up to DN150, PN16 over and Class 150 (PN20) from DN100 to 400
- With removable hoisting eye
- Short length
- Economical solution
- Monobloc disc and stem for a better mechanical strength
- Integrated body gasket

USE :

- Heating, water distribution
- Min and max Temperature Ts : - 10°C to + 110°C
- Max Pressure Ps : 16 bars up to DN 200 included and 10 bars over
- **Do not use with pulsatory speed**
- **Max Speed : 3 M. / Sec.**

CONNECTION :

- Carbon steel body with EPDM gasket between flanges PN10/16 up to DN150, PN16 over
- Between flanges Class 150 PN20 possible from DN100 to 400

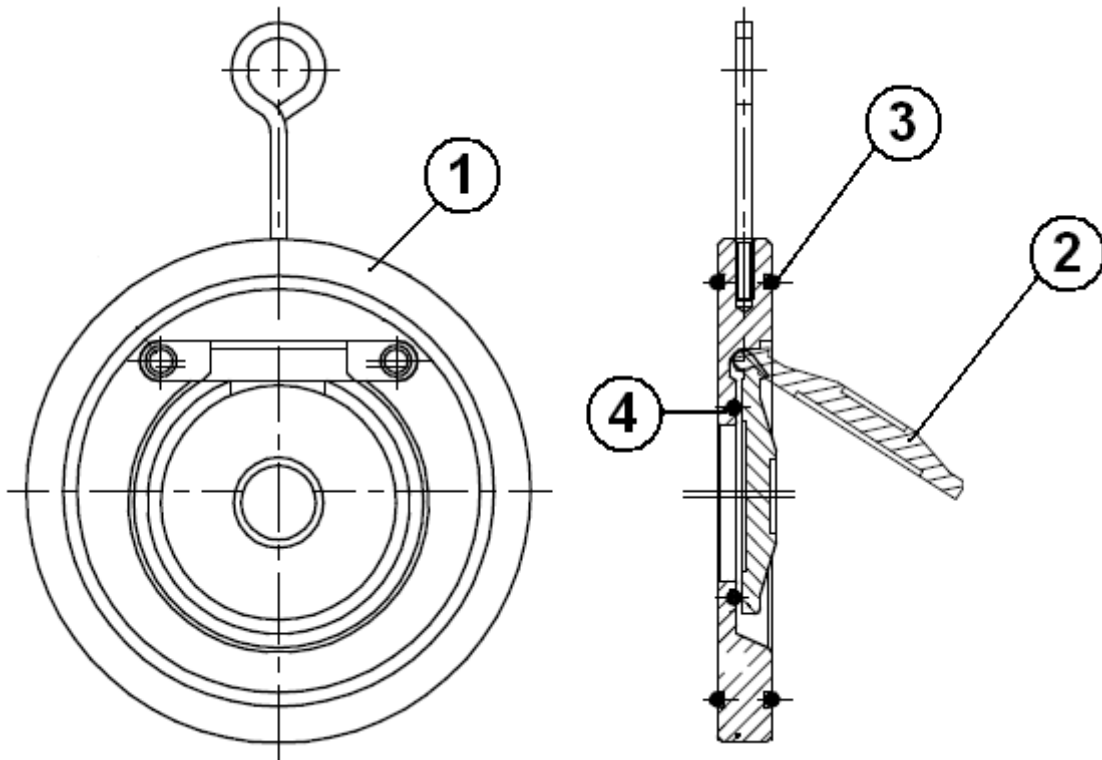
CARBON STEEL WAFER SWING CHECK VALVE EPDM**MATERIALS :**

Item	Designation	Materials
1	Body	Chromed ASTM A216 WCB
2	Disc	
3	Seat	EPDM
4	Gasket	EPDM

CARBON STEEL WAFER SWING CHECK VALVE EPDM

SIZE (in mm):

CLOSED CHECK VALVE

OPENED CHECK VALVE

GASKETS

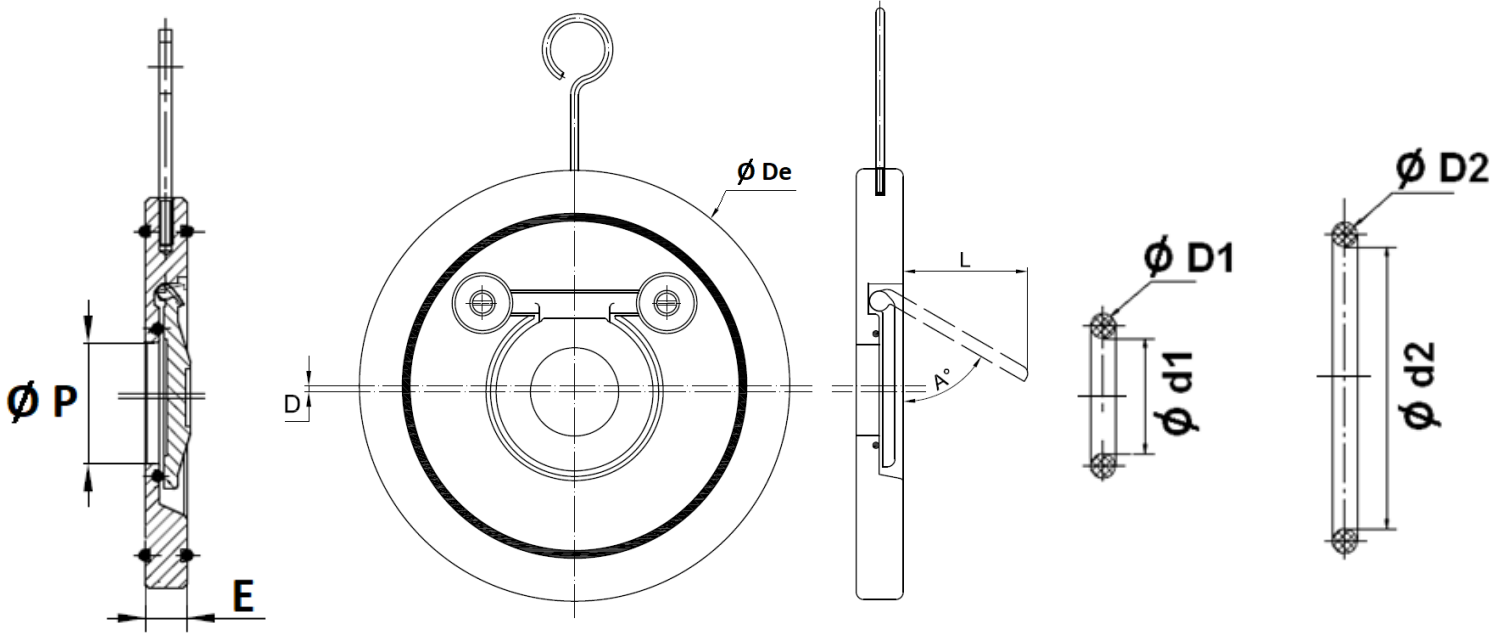

DN	40	50	65	80	100	125	150	200	250	300	350	400	450	500	600	
E	14	14	14	14	18	18	20	22	26	32	38	44	50	56	62	
Ø De	94	109	129	144	164	194	220	275	331	386	446	497	557	619	736	
Ø P	22	32	40	54	70	92	112	154	192	227	270	315	358	410	490	
L	24.5	33	32	47.7	70.4	93	112	149.3	171.9	225.7	229.6	268.2	296.7	329.5	434.8	
A (°)	54	54	34	43	55	60	59	58	53	61	48	48	46	46	54	
D	1	1	2	3	3	5	5	5	6	10	12	12	12	12	14	
Ø d2	70	80.5	100	107.5	134.5	158	186	240	284	328	385	435	486	534	630	
Ø D2	3.8									6	8					
Ø d1	24	34	46.5	59	72.5	93	113.5	156.5	194.5	231	283	328	375	426	510	
Ø D1	3				3.8					6	8					
Weight (Kg)	0.69	0.86	1.2	1.49	2.42	3.29	4.72	7.92	13.73	21.04	31.5	47	70	96	135	
Ref.	364040	364050	364065	364080	364100	364125	364150	364200	364250	364300	364350	364400	364450	364500	364600	

CARBON STEEL WAFER SWING CHECK VALVE EPDM**STANDARDS :**

- Manufacturer certified ISO 9001 : 2015
- Designing according to API 594 and EN 16767
- Pressure tests according to API 598, table 6
- DIRECTIVE 2014/68/EU : Products excluded (article 4, § 3)
- Certificate 3.1 on request
- Length according to EN 558 series 97 (NF 29377)
- Between flanges according to EN 1092-1 PN10/16

INSTALLATION POSITIONS :

Vertical position (ascendant fluid)

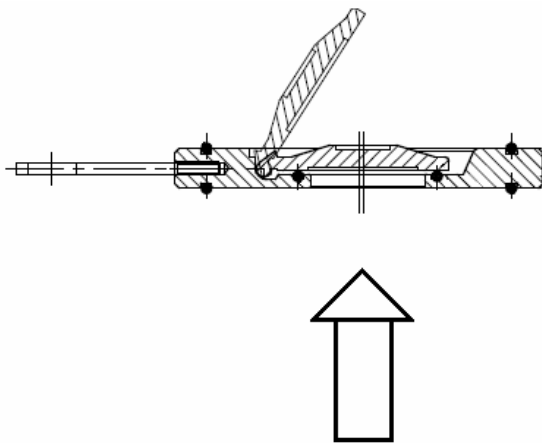

Horizontal position

