

## STAINLESS STEEL 3 PIECES DISC CHECK VALVE FEMALE BSP

3 pieces disc check valve female BSP for drinking water, chemical and pharmaceutical industries, petrochemical industries, hydraulic installation, compressed air.

Stainless steel type with PTFE gaskets. All positions.

Removable central part for an easy maintenance.

Metal/metal tightness (leakage rate according to API 598 standard)



**Size:** DN1/4" to DN4"

**Connection :** Female BSP

**Min Temperature :** -20°C

**Max Temperature :** +200°C

**Max Pressure :** 63 Bars

**Specifications :** Disc type

All positions

Metal/metal tightness

In accordance with the regulation EC 1935-2004

**Materials :** Stainless steel EN 1.4408

**STAINLESS STEEL 3 PIECES DISC CHECK VALVE FEMALE BSP**

**SPECIFICATIONS :**

- 3 pieces spring type
- All positions (respect the flow direction indicated by the arrow )
- Metal / metal tightness
- Stainless steel

**USE :**

- Chemical and pharmaceutical industries, petrochemical industries, hydraulic installation, compressed air, potable water
- Min Temperature Ts : - 20°C
- Max Temperature Ts :+ 200°C
- Max Pressure Ps : 63 bars ( see graph under )
- Steam : 11 bars max

**PRESSURE / TEMPERATURE GRAPH ( STEAM EXCLUDED ) :**

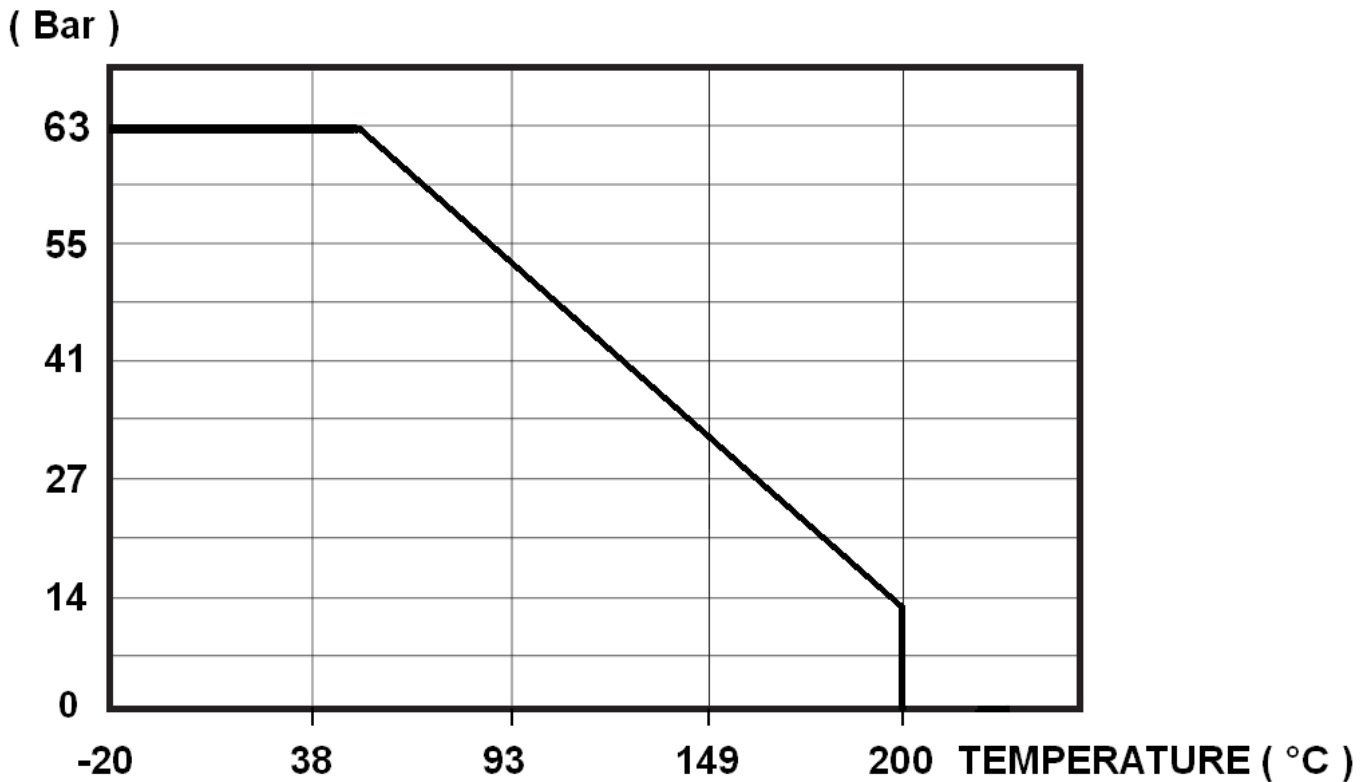

**FLOW COEFFICIENT Kvs ( M3 / h ) :**

NPS (")	1/4"	3/8"	1/2"	3/4"	1"	1"1/4"	1"1/2"	2"	2"1/2"	3"	4"
DN (mm)	8	10	15	20	25	32	40	50	65	80	100
Kvs ( m3/h )	1.23	1.23	2.24	6.5	9.61	15.89	22.49	25.12	57.8	64.93	91.6

**STAINLESS STEEL 3 PIECES DISC CHECK VALVE FEMALE BSP**

HEAD LOSS GRAPH :

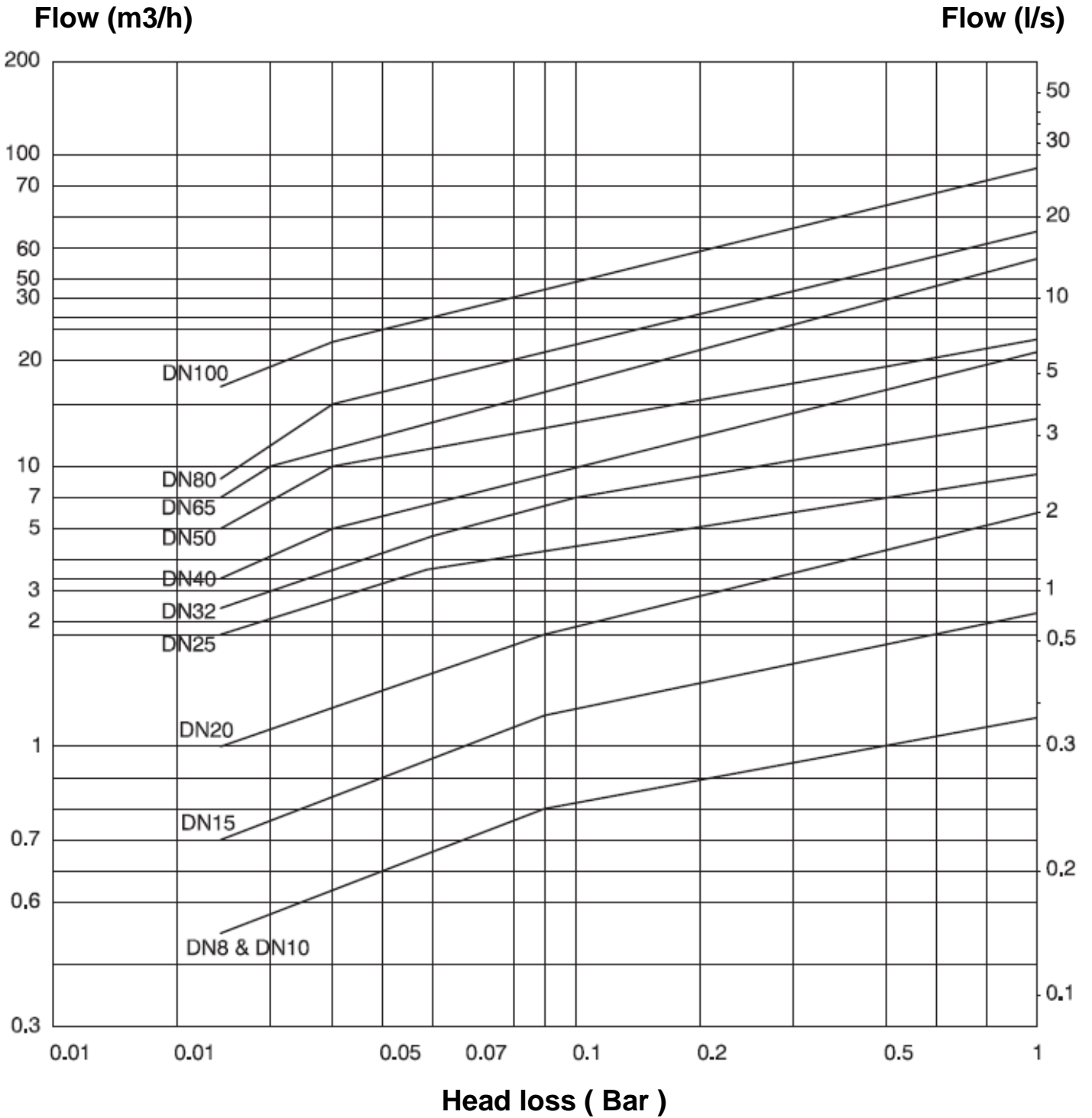

**STAINLESS STEEL 3 PIECES DISC CHECK VALVE FEMALE BSP**

**LEAKAGE RATE ACCORDING TO API 598 (DURING 60s):**

NPS (")	1/4"	3/8"	1/2"	3/4"	1"	1"1/4"	1"1/2"	2"	2"1/2"	3"	4"
DN	8	10	15	20	25	32	40	50	65	80	100
Liquid Test ( cc/min )	6								7.5	9	12
Gas Test (m3/h)	0.08								0.11	0.13	0.17

**OPENING PRESSURE ( in mbar ) :**

DN	Vertical Position ascending fluid	Horizontal Position
DN 08	25 ↑	23 →
DN 10	25 ↑	23 →
DN 15	25 ↑	23 →
DN 20	25 ↑	23 →
DN 25	25 ↑	23 →
DN 32	27 ↑	24 →
DN 40	29 ↑	25 →
DN 50	29 ↑	25 →
DN 65	31 ↑	25 →
DN 80	32 ↑	26 →
DN100	33 ↑	27 →

**BOLT TIGHTENING TABLE ( in Nm):**

DN	1/4"	3/8"	1/2"	3/4"	1"	1"1/4"	1"1/2"	2"	2"1/2"	3"	4"
Torque ( Nm )	30	30	30	30	45	45	45	60	75	90	105

**RANGE :**

- 3 pieces disc check valve female / female threaded BSP cylindrical **Ref. 380** from DN 1/4" to DN 4"

**STAINLESS STEEL 3 PIECES DISC CHECK VALVE FEMALE BSP**

**MATERIALS :**

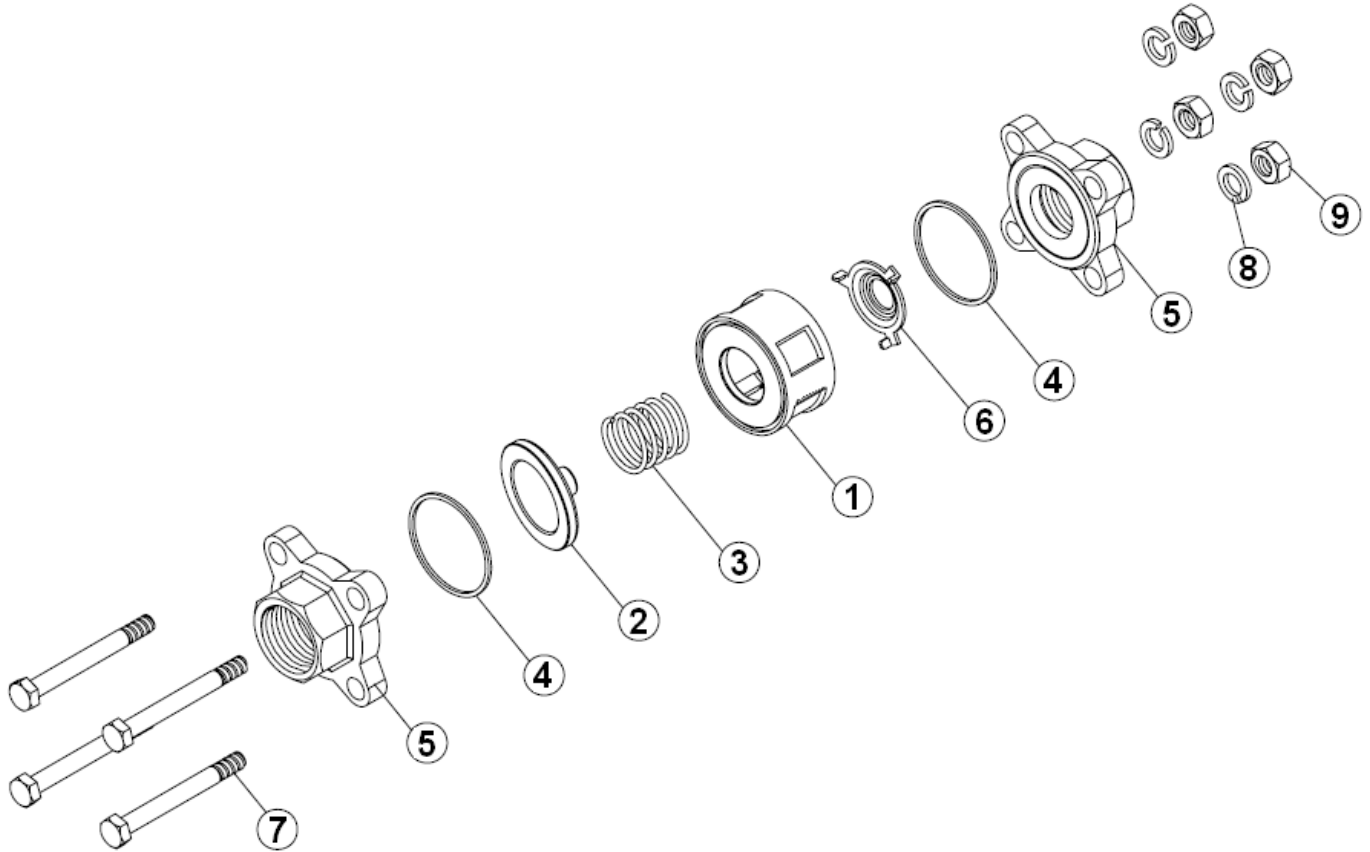

Item	Designation	Materials
1	Body	EN 1.4408
2	Disc	ASTM A240-316
3	Spring	
4	Gasket	PTFE
5	Ends	EN 1.4408
6	Spring holder	ASTM A240-316
7	Screw	AISI 304
8	Washer	
9	Nut	

**STAINLESS STEEL 3 PIECES DISC CHECK VALVE FEMALE BSP**

SIZE ( in mm ) :

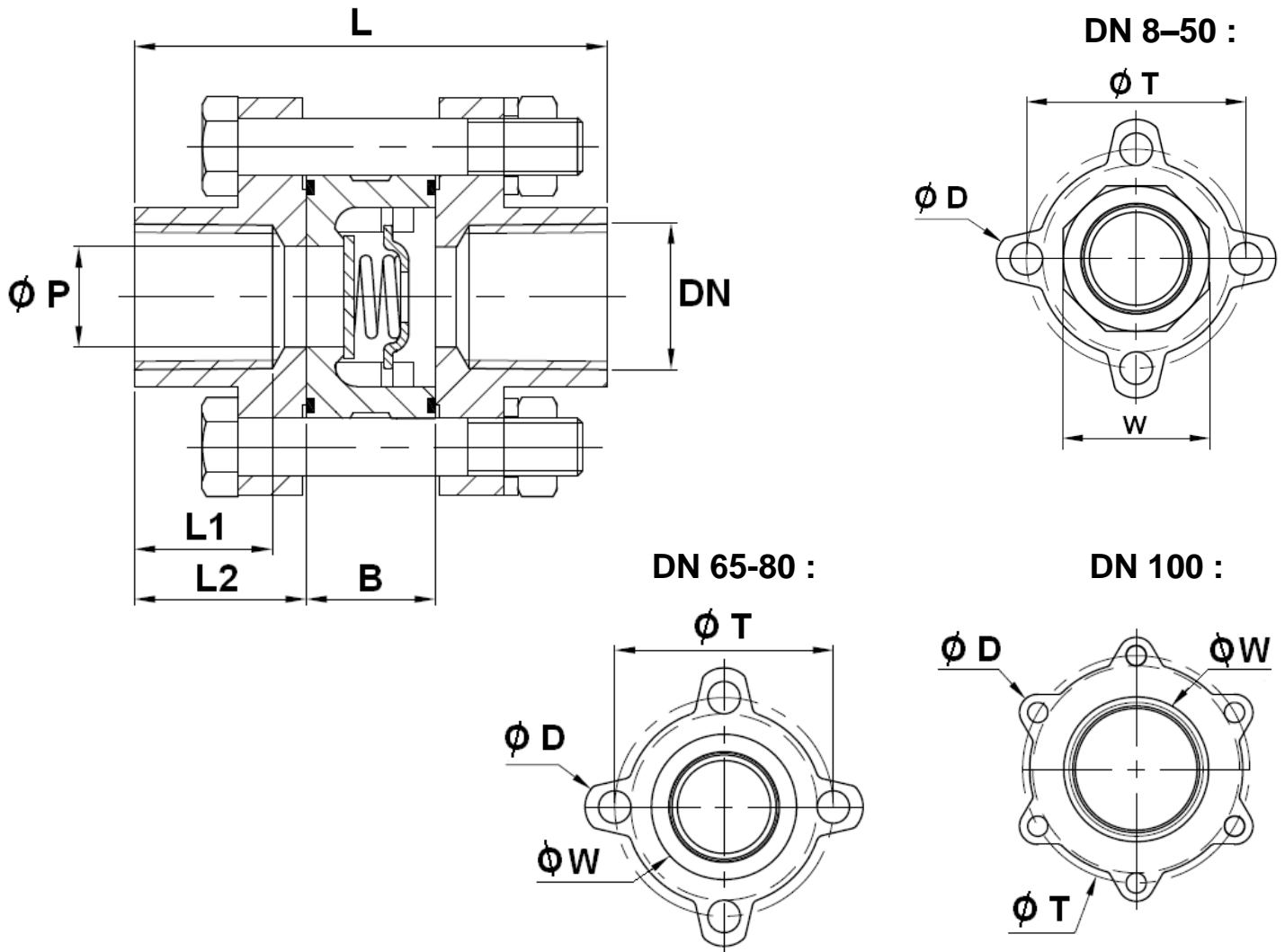

DN	1/4"	3/8"	1/2"	3/4"	1"	1"1/4	1"1/2	2"	2"1/2	3"	4"
Ø P	10	10	14	19	25	31	39	49	64	78	97
L	60	60	63	71	81.5	91	97.5	117	131.5	143.5	174.5
L1	16	16	18	20	20	23	23	27	33	35	45
L2	21	21	22	23.5	26	29	30	35	42	44	52
B	18	18	19	24	29.5	33	37.5	47	47.5	55.5	70.5
Ø D	12	12	14	16	16	18	18	18	18	18	18
Ø T	36.5	36.5	42.7	51.7	58.7	72.7	83.7	98.7	129	153.5	186.5
W	22	22	26	32	39	49	56	69	83	100	122.5
Weight (in Kg)	0.3	0.2	0.4	0.5	0.7	1.3	1.7	2.5	4.3	6.2	11
Ref.	380002	380003	380004	380005	380006	380007	380008	380009	380010	380011	380012

**STAINLESS STEEL 3 PIECES DISC CHECK VALVE FEMALE BSP****STANDARDS :**

- Manufacturer certified ISO 9001 : 2015
- DIRECTIVE 2014/68/UE : CE N° 0035  
Risk category III Module H
- Certificate 3.1 on request
- Construction according to EN 12516-1
- Designing according to ASME B16.34
- Pressure tests according to API 598, table 6
- BSP threaded cylindrical ends according to ISO 228-1
- ATEX Group II Category 2 G/2D Zone 1 & 21 Zone 2 & 22 ( optional marking )
- French water agreement **A.C.S. N° 17 ACC LY 341 from DN1/4" to 2"**
- Check valve in accordance with the regulation **(EC) N° 1935-2004 on request**

**STAINLESS STEEL 3 PIECES DISC CHECK VALVE FEMALE BSP****INSTALLATION INSTRUCTIONS****GENERAL GUIDELINES :**

- Ensure that the check valves to be used are appropriate for the conditions of the installation (type of fluid, pressure and temperature).
- Be sure to have enough valves to be able to isolate the sections of piping as well as the appropriate equipment for maintenance and repair.
- Ensure that the check valves to be installed are of correct strength to be able to support the capacity of their usage.
- **Installation of all circuits should ensure that their function can be automatically tested on a regular basis (at least two times a year).**

**INSTALLATION INSTRUCTIONS :**

- **Before installing the check valves, clean and remove any objects from the pipes** (in particular bits of sealing and metal) which could obstruct and block the check valves.
- **Ensure that both connecting pipes either side of the check valve (upstream and downstream) are aligned (if they're not, the valves may not work correctly).**
- **Make sure that the two sections of the pipe (upstream and downstream) match, the check valve unit will not absorb any gaps. Any distortions in the pipes may affect the tightness of the connection, the working of the check valve and can even cause a rupture.** To be sure, place the kit in position to ensure the assembling will work.
- **During welding operation, be sure to not exceed 200°C**
- **If sections of piping do not have their final support in place, they should be temporarily fixed. This is to avoid unnecessary strain on the check valve.**
- **Fluids in the check valve must not contain solid objects ( it could damaged the seat ).**
- If there is a direction changing or if there's another material, it's better to take away the check valve so that it is outside the turbulence area ( **between 3 and 5 times the ND before and after** ).
- After a pump please refer to **FD CEN/TR 13932** to install the check valve :
  - If it is essential to keep priming the pump, a non-return check valve can be fitted to the suction pipe at a distance **L1 ( straight length suction ) > 10xD1 (diameter suction )**  
The check valve is designed to meet the maximum flow rate in service
  - In other cases, the non-return check valve is mounted on the discharge pipe at a distance of **L2 (straight length at discharge) > 3xD2 (diameter at discharge)**